



15th International Scientific Conference

Energy and Climate Change



PROCEEDINGS

organized by
Energy Policy and Development Centre (KEPA)
National and Kapodistrian University of Athens
2022



Sponsored by



Editor

Prof. Dimitrios MAVRAKIS

Energy Policy and Development Centre (KEPA) of the National and Kapodistrian University of Athens

Scientific Committee

Prof. Miroљjub ADZIC, University of Belgrade, Serbia

Prof. Rauf ALIYAROV, National Academy of Sciences, Azerbaijan

Prof. Mihail CHIORSAC, Academy of Sciences of Moldova, Moldova

Prof. Eduardo CROCI, Bocconi University, Italy

Prof. Athanasios DAGOUMAS, University of Piraeus, Greece

Prof. Kiriakos GEORGIU, National and Kapodistrian University of Athens, Greece

Prof. Rajat GUPTA, Oxford Brookes University, United Kingdom

Prof. George HALKOS, University of Thessali, Greece

Prof. Dejan IVEZIC, University of Belgrade, Serbia

Prof. Nikola KALOYANOV, Technical University of Sofia, Bulgaria

Dr. Yannis KABOURIS, Director for Foreign Affairs in IPTO, Greece

Prof. Constantinos KARAGIANNOPOULOS, National Technical University of Athens, Greece

Prof. Andonaq LAMANI LONDO, Polytechnic University of Tirana, Albania

Prof. Haji MALIKOV, National Academy of Sciences, Azerbaijan

Prof. Dimitrios MAVRAKIS, National and Kapodistrian University of Athens, Greece

Prof. Kenichi MATSUMOTO, University of Shiga Prefecture, Japan

Prof. Nikitas NIKITAKOS, University of the Aegean, Greece

Prof. Katherine PAPPAS, National and Kapodistrian University of Athens, Greece

Prof. Anca POPESCU, Institute for Studies and Power Engineering, Design and Consulting, Romania

Prof. Tom SKAUGE, Bergen University College and University of Oslo, Norway

Prof. Milton A. TYPAS, National and Kapodistrian University of Athens, Greece

Scientific Secretariat

Dr. Popi KONIDARI

Aliki-Nefeli MAVRAKI, MSc.

Energy Policy and Development Centre (KEPA) of the National and Kapodistrian University of Athens

ISBN: 978-618-84817-6-3 (e-book)

ISSN: 2241-7850-3

Contents

Agenda	5
List of participants	11
DAY 1: 9th Green Energy Investments Forum	15
Session 1 – Policy makers	15
Introductory remarks by Prof. Dimitrios MAVRAKIS	17
Key-note speech by Amb. Constantinos ORPHANIDES	21
Main points of Amb. Lazar COMANESCU’s speech	23
Main points of Amb. Andrei POPOV’s speech	25
Remarks by Prof. Asaf HAJIYEV	27
Speech of Amb. Burak ÖZÜGERGİN	31
Speech of Amb. David DONDUA	33
Main points of Amb. Jakub KARFIK’s speech	35
Speech of Amb. Amrit LUGUN	37
DAY 1: 9th Green Energy Investments Forum	39
Session 2 – Symposium (Working lunch)	39
The 1st BSEC-GEN and BSEC-PERMISS Symposium	41
Address by Prof. Andonaq LONDO LAMANI	43
Intervention of Dr. Mihai TIRSU	45
Address by Prof. Dejan IVEZIC	47
Conclusions	49
DAY 2: Scientific Sessions	51
Opening speech by Prof. Dimitrios KARADIMAS	53
UNAI Hub SDG 9 - Industry, Innovation and Infrastructure	55
UNAI Hub SDG 10 - Reduced Inequalities	63
UNAI Hub SDG 13 – Climate Action	67
UNAI Hub SDG 16 – Peace, Justice and Strong Institutions	75
Opportunity for the development of renewable energy in Azerbaijan	81
Vertical Green Structures Impact on Microclimate: A case study in Milan	89
Using Earth Observation Application to Air Quality in Addition to in-situ monitoring: HARMONIA IRAP platform	97
The Regional Climate Adaptation Plan of Crete as a strategic planning cornerstone for the protection of the natural environment and the resilience of infrastructure in a climate hotspot area	103
Reducing the life cycle impact of an office building by improving systems control. A case study.	113

Geothermal resources and local development in Poland	125
On the possibility of a cyber-attack on optimizer-based photovoltaic generators	131
DAY 3: Brokerage event	137
Session 1 – Projects	137
Numerical evaluation of the impact of some design parameters of centrifugal fans on their energy efficiency. Corresponding algorithm in the Python language	139
Electricity Generation Using Solar Power in Industrial Application – Case Study	151
An innovative flexibility management and optimization framework for demand side aggregators	161
Education and Citizen engagement as drivers for ecological transition: the GreenSCENT project	175
Adaptive management of mitigation projects implemented in rural areas: contribution to Kazakhstan's goal of carbon neutrality	183
Meleagros, an integrated fire protection system	193
Initiative “75UN – 75 Trees UNAI SDG7”	201
DAY 3: Brokerage event	207
Session 2 – Innovation – Start ups	207
Innovation Fund	209
Innovation and Networking	213
Startup Greece	221
Ependysis Business Consultants	229
Deger Hellas.....	239
PJ TECH Catalyst	255

Agenda



Forum 12.10.22

09.30 – 10.00 Registration

10.00 – 13.00 Session 1 – Policy makers

Chair: **H.E. Amb. Dimitrios RALLIS**, Deputy Secretary General of PERMIS – BSEC

Co-chair: **Prof. Dimitrios MAVRAKIS**, Director of KEPA, BSEC – GEN

10.00 – 10.15 **Prof. Dimitrios MAVRAKIS**, BSEC - GEN & UNAI Hub SDG7
Introductory remarks

Key-note speakers

10.15 – 10.30 **H.E. Costantinos ORPHANIDES**, Minister Plenipotentiary of 1st class
Hellenic Ministry of Foreign Affairs

10.30 – 10.45 **H.E. Lazăr COMĂNESCU**
Secretary General PERMIS – BSEC

10.45 – 11.00 **H.E. Andrei POPOV**
Amb. of the Republic of Moldova in Greece
Current Chairmanship-in-office of BSEC

11.00 – 11.15 **H.E. Prof. Asaf HAJIYEV**
Secretary General of PABSEC

11.15 – 11.30 **H.E. Burak OZUGERZIN**
Amb. of the Republic of Turkey in Greece

11.30– 11.45 **H.E. David DONDUA**
Amb. of the Republic of Georgia in Greece

11.45 – 12.00 **H.E. Jakub KARFIK**
Amb. of the Czech Republic in Greece
Current Presidency of the Council of European Union

12.00 – 12.15 **H.E. Amrit LUGUN**
Amb of the Republic of India in Greece

12.15 – 12.30 **Prof. Dimitrios MAVRAKIS**, Director of KEPA
Coordinator of BSEC -GEN, UNAI Hub SDG7

Concluding Remarks

12.30 – 12.45 **H.E. Dimitrios RALLIS**
Deputy Secretary General of PERMIS – BSEC





13.00 – 15.00 Session 2 – Symposium (Working lunch)

Title: Perspectives of green investments in Member States of BSEC with developing economies.

(An exchange of views in search of effective ways of regional cooperation)

1. Moderator: Prof. Dimitrios MAVRAKIS
Director of KEPA, BSEC -GEN, UNAI Hub SDG7

Panellists

- 2. H.E. Lazăr COMĂNESCU**
Secretary General of PERMIS – BSEC
- 3. H.E. Dimitrios RALLIS**
Deputy Secretary General of PERMIS – BSEC
- 4. H.E. Andrei POPOV**
Ambassador - designate of the Rep. of Moldova
Current Chairmanship-in-office of BSEC
- 5. H.E. David DONDUA**
Amb. of the Republic of Georgia in Greece
- 6. H.E. Prof. Asaf HAJIYEV**
Secretary General of PABSEC
- 7. Prof. Antonaq Londo LAMANI**
Technical University of Tirana – Albania
- 8. Prof. Rauf ALIYAROV**
Director of the Scientific Research Institute Geotechnological Problems of Oil, Gas and Chemistry - Azerbaijan
- 9. Prof. Haji MALIKOV**
Geotechnological Problems of Oil, Gas and Chemistry - Azerbaijan
- 10. Prof. Mihai TIRSU**
Director of Institute of Power Engineering, Academy of Sciences of Moldova
- 11. Prof. Dejan IVEZIC**
University of Belgrade – Serbia
- 12. Dr. Popi KONIDARI**
Energy Policy and Development Centre of NKUA – Greece
- 13. Ms. Eleni – Danai MAVRAKI**
Energy Policy and Development Centre of NKUA – Greece

Concluding Remarks





Scientific Sessions – Thursday 13.10.2022

10.00 – 12.55 Session 1 – Environment – Climate Change

Chair: **Prof. Dimitrios MAVRAKIS**
Director of KEPA, BSEC – GEN

Co-chair: **Prof. Haji MALIKOV**
Scientific Research Institute “Geotechnological Problems of Oil, Gas and Chemistry” - Azerbaijan

Opening

10.00 – 10.10 **Prof. Dimitrios KARADIMAS**
Vice Rector NKUA

10.10 – 10.50 **Dr. Mami KATSUMI**
Nagaoka University of Technology, Japan

UNAI Hub SDG 9 - Industry, Innovation and Infrastructure

Prof. Mwangi Peter WANDERI
Mount Kenya University, Kenya

UNAI Hub SDG 10 - Reduced Inequalities

Mrs. María Soledad CASASOLA (video)
Universidad Nacional de Rosario, Argentine

UNAI Hub SDG 13 – Climate Action

Mr. Mark CHARLTON (video)
De Montfort University, United Kingdom

UNAI Hub SDG 16 - Peace, Justice and Strong Institutions

10.50 – 11.10 **Prof. Rauf ALIYAROV**
Director of the Scientific Research Institute “Geotechnological Problems of Oil, Gas and Chemistry”, Azerbaijan

Presentations

11.15 – 11.35 **Prof. Arash FARNOOSH**
IFP Energies Nouvelles (IFPEN), IFP School, Center for Energy Economics and Management, France

“Analysis of the synergistic effects of policy instruments in environmental governance taking into account the social context”





11.35 – 11.55 **Prof. Julia Nerantzia TZORTZI**

Politecnico di Milano, Italy

“How are European Cities addressing climate change and building urban resilience through Project Harmonia?”

12.15 – 12.35 **Ms. Ozge OGUT** (on line)

Politecnico di Milano, Italy

“Using Earth Observation Data as Tool to Develop Public Health by improving Air Quality: HARMONIA project within Climate Change”

12.35 – 12.55 **Ms. Ozge OGUT** (on line)

Politecnico di Milano, Italy

“Vertical Green Structures Impact on Microclimate: A case study in Milan”

13.00 – 13.15 **Coffee Break**

13.15 – 14.35 Session 2 – Climate Change - Energy

Chair **Prof. Milton A. TYPAS**

National and Kapodistrian University of Athens

Co-chair **Prof. Dejan IVEZIC**

University of Belgrade - Serbia

13.15 – 13.35 **Mr. Antonios SAKALIS**

ENVIROPLAN Consultants & Engineers S.A., Greece

“The Regional Climate Adaptation Plan of Crete as a strategic planning cornerstone for the protection of the natural environment and the resilience of infrastructure in a climate hotspot area”

13.35 – 13.55 **Prof. Vilūnė LAPINSKIENĖ** (on line)

Vilnius Gediminas Technical university – Lithuania

“Reducing the Life Cycle Analysis of Building Automation Systems operation”

13.55 – 14.15 **Dr. Katarzyna A. KUREK** (on line)

Wageningen University and Research, The Netherlands

“Geothermal resources and local development in Poland”

14.15 – 14.35 **Prof. Alon KUPERMAN**

Ben-Gurion University of the Negev, Israel

“On the possibility of a cyber-attack on optimizer-based photovoltaic generators”





Brokerage and Start-ups outline – Friday 14.10.2022

10.00 – 12.15 Session 1 – Projects

Chair: **Prof. Kyriacos Ch. GEORGHIOU**
National and Kapodistrian University of Athens - Hellas

Co-chair: **Prof. Antonaq Londo LAMANI**
Technical University of Tirana – Albania

Presentations

- 10.00 – 10.20 **Dr. Luis LAMANI**
Polytechnic University of Tirana, Albania
“Numerical evaluation of the impact of some design parameters of centrifugal fans on their energy efficiency. Corresponding algorithm in the Python language.”
- 10.20 – 10.40 **Prof. Assoc. Astrit BARDHI**
Polytechnic University of Tirana, Albania
“Electricity Generation Using Solar Power in Industrial Application – Case Study”
- 10.40 – 11.00 **Mr. Konstantinos TSATSAKIS** (on line)
Suite 5, Cyprus
“An innovative flexibility management and optimization framework for demand side aggregators”
- 11.00 – 11.20 **Prof. Maria Amata GARITO** (on line)
Universita Telematica Internazionale UNINETTUNO, Italy
“Education and Citizen engagement as drivers for ecological transition: the GreenSCENT project”
- 11.20 – 11.40 **Prof. Gulzhamal JAPAROVA** (on line)
Turan-Astana University, Kazakhstan
“Adaptive management of mitigation projects implemented in rural areas: contribution to Kazakhstan’s goal of carbon neutrality”
- 11.40 – 12.00 **Dr. Odysseas SEKKAS**
Mobics SA
“Meleagros, an integrated fire protection system”
- 12.00 – 12.15 **Dr. Popi KONIDARI**
Energy Policy and Development Centre of NKUA, Hellas
“Initiative 75UN – 75 Trees UNAI SDG7”





12.15 – 15.15 Session 2 – Innovation – Start ups

Chair: **Prof. Milton A. TYPAS**
National and Kapodistrian University of Athens - Hellas

Co-chair: **Dr. Mihai TIRSU**
Institute of Power Engineering - Moldova

Key - note Speakers

12.15 – 12.35 **Mr. Georgios ZISIS-TEGOS**
Ministry of Environment and Energy, Hellas
Innovation Fund

12.35 – 12.55 **Ms. Varvara VASILAKI**
National Documentation Centre, Hellas
Innovation and Networking

12.55 – 13.15 **Mr. George PROKOPOS**
Startup Greece

13.15 – 13.35 **Mr. Ypsilantis TZOUROS**
Ependysis Business Consultants

13.35 – 13.55 **Dr. Ioannis MARKOPOULOS**
DegerHellas

13.55 – 14.15 **Mr. Nikos ANTONIOU**
PJ TECH Catalyst

14.15 – 14.45 Panel – Discussion

14.45 – 15.00 Closing remarks

End of Conference



List of participants

No.	Title	First Name	Last Name	Organization
1.	Prof.	Rauf	Aliyarov	Geotechnological Problems of Oil, Gas and Chemistry, Azerbaijan
2.	Mr.	Nikos	Antoniou	PJ TECH Catalyst, Hellas
3.	Mrs.	Rania	Baltzi	Ependysis Business Consultants, Hellas
4.	Prof.	Astrit	Bardhi	Technical University of Tirana, Albania
5.	Amb.	Lidija	Boshkovska	Embassy of the Republic of North Makedonia in Hellenic Republic
6.	Mrs.	María Soledad	Casasola	Universidad Nacional de Rosario, Argentine
7.	Mr.	Mark	Charlton	De Montfort University, United Kingdom
8.	Amb.	Michael	Christides	Amb. a.h., Hellas
9.	Ms	Jitka	Chromcova	Embassy of the Czech Republic in Hellenic Republic
10.	Amb.	Lazar	Comanescu	Black Sea Economic Cooperation-PERMIS
11.	Amb.	David	Dondua	Embassy of the Republic of Georgia in the Hellenic Republic
12.	Dr.	Athanasios	Dagoumas	Regulatory Authority of Energy, Hellas
13.	Dr.	Alexandros	Eleftheriadis	International Hellenic University, Hellas
14.	Prof.	Arash	Farnoosh	IFP Energies Nouvelles (IFPEN), IFP School, Center for Energy Economics and Management, France
15.	Mrs.	Teresa	Fokianou	Flow Energy S.A., Hellas
16.	Mrs.	Panagiota	Gazi	KEDE, Hellas
17.	Prof.	Kiriakos	Georgiou	National and Kapodistrian University of Athens, Hellas
18.	Prof.	Asaf	Hajiyev	PABSEC
19.	Mr.	Ioannis	Hatzimaliakas	Eurobank, Hellas

20.	Prof.	Lyubov	Inyuitina	Turan-Astana University, Kazakhstan
21.	Mrs.	Elvira	Isufi	Embassy of Albania in Hellenic Republic
22.	Prof.	Dejan	Ivezic	University of Belgrade, Serbia
23.	Prof.	Gulzhamal	Japarova	Turan-Astana University, Kazakhstan
24.	Ms	Martina	Kapounova	Embassy of the Czech Republic in Hellenic Republic
25.	Amb.	Jakub	Karfik	Embassy of the Czech Republic in Hellenic Republic
26.	Prof.	Dimitrios	Karadimas	National and Kapodistrian University of Athens, Hellas
27.	Ms.	Eleni	Kargaki	Prefecture of Crete, Hellas
28.	Dr.	Mami	Katsumi	Nagaoka University of Technology, Japan
29.	Mr.	Kostas	Komninos	DAFNI Network, Hellas
30.	Dr.	Popi	Konidari	KEPA, Hellas
31.	Ms.	Sevasti	Kontaxi	Municipality of Preveza, Hellas
32.	Mr.	Marinos	Kritsotakis	Prefecture of Crete, Hellas
33.	Prof.	Alon	Kuperman	Ben-Gurion University of the Negev, Israel
34.	Dr.	Katarzyna	Kurek	Wageningen University and Research, The Netherlands
35.	Prof.	Andonaq	Londo Lamani	Technical University of Tirana, Albania
36.	Dr.	Luis	Lamani	Technical University of Tirana, Albania
37.	Prof.	Vilūnė	Lapinskiene	Vilnius Gediminas Technical University, Lithuania
38.	Amb.	Amrit	Lugun	Embassy of the Republic of India in Hellenic Republic
39.	Mrs.	Maria Stella	Lux	Politecnico di Milano, Italy
40.	Mr.	George	Malamas	KEPA, Hellas
41.	Prof.	Haji	Malikov	Scientific Research Institute "Geotechnological Problems of Oil, Gas and Chemistry", Azerbaijan
42.	Mrs.	Aglaia	Marathia	Municipality of Patra, Hellas

43.	Dr.	Ioannis	Markopoulos	DegerHellas, Hellas
44.	Ms.	Aliki-Nefeli	Mavraki	KEPA, Hellas
45.	Mrs.	Eleni-Danai	Mavraki	KEPA, Hellas
46.	Prof.	Dimitrios	Mavrakis	KEPA, Hellas
47.	Mr.	Stavros	Mavroudeas	ENVENA Ltd., Hellas
48.	Mr.	Athanasios	Mosxos	Eurobank, Hellas
49.	Mr.	Theodoros	Mpalomenos	University of Thessalia, Hellas
50.	Ms.	Ivi-Kleio	Nanopoulou	THYMIOS PAPAGIANNIS AND ASSOCIATES, Hellas
51.	Mrs.	Anastasia	Nani	Embassy of Moldova in Hellenic Republic
52.	Mr.	Ioannis	Ntroukas	Eda Attikis, Hellas
53.	Ms.	Ozge	Ogut	Politecnico di Milano, Italy
54.	Ms.	Christina	Oikonomou	Hellenic Ministry of Foreign Affairs
55.	Mr.	Costantinos	Orphanides	Hellenic Ministry of Foreign Affairs
56.	Amb.	Burak	Ozugerzin	Embassy of the Republic of Turkey in Hellenic Republic
57.	Mr.	Fotis	Panagopoulos	Municipality of Artemida, Hellas
58.	Prof.	Aikaterini	Pappas	National and Kapodistrian University of Athens, Hellas
59.	Mr.	Thanos	Parasxos	Startup Greece, Hellas
60.	Amb.	Andrei	Popov	Embassy of the Republic of Moldova in Hellenic Republic
61.	Mr.	George	Prokopos	Startup Greece, Hellas
62.	Mr.	Ioannis-Marios	Psimadas	Tetragon, Hellas
63.	Amb.	Dimitrios	Rallis	Black Sea Economic Cooperation-PERMIS
64.	Ms.	Olivia	Redler	The American College of Greece - Deree
65.	Mr.	Antonios	Sakalis	ENVIROPLAN Consultants & Engineers S.A., Hellas
66.	Mr.	Odysseas	Sekkas	Mobics SA, Hellas
67.	Amb.	Sergii	Shutenko	Embassy of Ukraine in Hellenic Republic

68.	Amb.	Panteley	Spasov	Embassy of Bulgaria in Hellenic Republic
69.	Ms.	Janka	Szemesova	Slovak Hydrometeorological Institute, Slovenia
70.	Prof.	Mihai	Tirsu	Institute of Power Engineering, Moldova
71.	Ms.	Natassa	Triantafyllou	B GROUP Sole Individual Company Investment Company Services, Hellas
72.	Mr.	Konstantinos	Tsatsakis	Suite 5, Cyprus
73.	Prof.	Milton	Typas	National and Kapodistrian University of Athens, Hellas
74.	Ms.	Marianna	Tzebelika	Open University, Hellas
75.	Prof.	Julia Nerantzia	Tzortzi	Politecnico di Milano, Italy
76.	Mr.	Ypsilantis	Tzouros	Ependysis Business Consultants, Hellas
77.	Ms.	Varvara	Vasilaki	National Documentation Centre, Hellas
78.	Mrs	Anna	Vasylets	Embassy of Ukraine in Hellenic Republic
79.	Mrs.	Chrysanthi	Vgiatzi	Prefecture of Crete, Hellas
80.	Mr.	George	Zisis -Tegos	Ministry of Environment and Energy, Hellas
81.	Prof.	Mwangi Peter	Wanderi	Mount Kenya University, Kenya
82.	Mr.	Nikolaos	Xilouris	Deputy Governor of Crete, Hellas

DAY 1: 9th Green Energy Investments Forum

Session 1 – Policy makers

Introductory remarks by Prof. Dimitrios MAVRAKIS

Director of KEPA, National and Kapodistrian University of Athens, Hellas



Ladies and gentlemen

Last year the conclusions of the 8th Forum included a call to the BSEC member states to develop programmes and actions capable to tackle energy poverty in their countries.

These conclusions were presented by KEPA at the meeting of the Working Group on Energy of the BSEC countries in Istanbul on the 2nd of December 2021.

The esteemed participants refrained from discussing or making any decision. The issue of establishing procedures leading to efficient ways confronting energy poverty in our societies has been of concern among the members of the Green Energy Network for quite a long time.

Under the coordination of BSEC – GEN, a number of project proposals have been submitted to BSTDB and BSEC for financing in the past, in vain.

Universities from Albania, Armenia, Bulgaria, Greece, Romania, Russia, and Serbia, as well as from Italy and the United Kingdom had participated in the relevant consortia providing the necessary state-of-the-art of knowledge on resolving issues relevant to Energy Poverty.

Even a special Forum, sponsored by KEPA, was organized by the BSEC – GEN at the BSEC headquarters with the participation of scientists from the aforementioned countries, again to no avail.

This year our societies face a complex of difficult challenges that increase energy poverty in our households.

Climate change, security of energy supply and global economic recession create a destructive spiral that threatens mostly the low-income people.

Energy poverty is already affecting an increasing number of households and these trends create a dangerous perspective that threatens the social peace and stability of our countries.

It is for these reasons that I am coming back to ask for your attention and support, in a bankable proposal which aims to relieve these most vulnerable parts of our societies.

It is a business-oriented proposal with nothing to do with subsidies or charities. It is a pure win-win proposal based on the wealth that can be produced by RES.

The proposal is based on the development and implementation of a Structured Policy Dialogue (SPD) targeting the gradual engagement of all the necessary actors in scheduled actions leading to the alleviation of poor households suffering from energy poverty.

The hard core of the proposal lies in the development of the necessary financing tools allowing the issue of secured bankable loans targeting access to sufficient RES generation for defined beneficiaries, with the active involvement of their local authorities.

In this SPD there are three groups of actors that initially agree on the procedures and their gradual involvement in the whole process.

The first group includes local authorities and the beneficiary households suffering from energy poverty.

Criteria and terms of participation for the beneficiaries are defined by the local authorities that undertake the obligation to represent them in the whole spectrum of activities, in both the banking and energy constructing or energy providing sectors.

The second group includes energy constructors or providers that undertake to provide the necessary infrastructure or the agreed amount of energy to beneficiaries through their local authorities.

The third group includes the funding sector consisted of an initial funding scheme that creates an independent funding entity capable to provide the required funds to commercial banks that undertake to issue the necessary loans for the beneficiaries with the collateral involvement of their local authorities.

Financing of eligible consumers is carried out by loans issued by commercial banks through legal entities created by local authorities.

The payment of loan tranches, received by the beneficiaries, is agreed upon the basis of their financial capabilities. An agreed excess of electricity production, per consumer, is collected in a pool, as collateral for the issued loans.

Pooling tranches of issued loans in a Special Purpose Vehicle allows the banks to transfer the loan portfolio to the initial funding entity and raise additional funding.

I will not go on with further details that will be clarified in later stages when the SPD will have started functioning.

On the other hand, I find it quite important to underline the decisive role that the Black Sea Trade and Development Bank can play in the successful implementation of this proposal.

The mission of BSTDB among others is «...to effectively contribute to the transition process of the Member States towards the economic prosperity of the people of the region...» and this fits well with this initiative.

BSTDB has been operating so far, as a pure commercial Bank, severed from the demonstration of the expected corporate responsibility to the people and societies of the BSEC - MS in line with its mission, as it is written in its constitutional statute.

In this context, allow me the proposal to both the current chairmanship-in-office of BSEC and to the PERMIS to raise the issue to BSEC - MS with the aim to instruct their governors in BSTDB to enhance its role so as to include the task of corporate responsibility in its activities.

BSTDB with its network of national commercial banks and its interconnections with international financial institutions can be the ideal catalyst for the enrichment of regional economic cooperation and the formulation of such green investment tools and programs

Green Energy Network, established by the governments of BSEC, has the potential to act as an advisor to the Bank for the development of the necessary funding tools and the implementation of the relevant “Structured Policy Dialogue”.

KEPA can undertake to present this proposal to the forthcoming Working Group on Energy next month provided that the necessary preliminary deliberations will be carried out with BSTDB.

Ladies and gentlemen,

I have abstained, on purpose, from mentioning other initiatives of BSEC -GEN since my aim was to attract your attention to the issue of energy poverty.

Further information for our initiatives is included in the printed material already disseminated to you.

I close my presentation by mentioning that I will be glad if in the next year's Forum, we have the opportunity to discuss the follow-up of concrete projects on Energy Poverty.

Short CV

Prof. Dimitrios MAVRAKIS is the Director of KEPA, the UNAI hub for SDG7; coordinator of the “BSEC – Green Energy Network” focused on Renewable Energy Sources (RES) and Energy Efficiency (EE) for scientists, market stakeholders, and policy makers, from the countries of BSEC under the supervision of BSEC – PERMIS; coordinator of PROMITHEASnet, the Energy and Climate Change Policy Network, consisted of academic institutes from S.E. Europe, Black Sea and Central Asia; Chief editor of the “Energy View of the BSEC countries”; Chief editor of the “Energy View of the BSEC countries”; Chief editor of the “Euro-Asian Journal of Sustainable

Energy Development Policy”; Editor of the worldwide disseminated “PROMITHEAS newsletter”; Chairman of the annual international scientific conference on “Energy and Climate Change” (13th year); Initiator of the European Energy Community.

His main studies and activities are related with energy geopolitics, development of regional energy markets, energy interconnections, transcontinental energy corridors, design of climate policy instruments, exploration of interactions between climate policy tools, development and assessment of mitigation/adaptation policy mixtures.

He was appointed as member of the Advisory Groups on Energy (AGE) of E.C. for FP6 and FP7 and was the Project Coordinator of several FP6, FP7 and H2020 projects.

Current activities: *He currently promotes the “UNAI Hub SDG7 Society”, the “75 UN – 75 Trees UNAI SDG7” initiative and the Green Energy Investments Fora among the BSEC - MS. He also promotes regional cooperation on Climate Change Policy issues among academic institutions, governmental authorities and market stakeholders from the countries of EU and the BSEC; knowledge transfer about climate change, EE, RES, development of scenarios for mitigation/adaptation, looking-forward energy modelling; he participates in the BSEC Working Group on energy.*

Key-note speech by Amb. Constantinos ORPHANIDES

Minister Plenipotentiary of 1st class, Hellenic Ministry of Foreign Affairs



Honorable Professor Dimitrios Mavrakis,

Your Excellency Secretary General of PERMIS BSEC,

Your Excellencies colleagues Ambassadors,

Esteemed ladies and gentlemen,

Allow me first to present myself, I am Constantinos Orphanides, I am a career diplomat having served in many posts both abroad and in the Headquarters of the Ministry of Foreign Affairs in Athens. Abroad, my last posting was as Ambassador of Greece to the State of Qatar, and in Athens, the last one before my present position, was as Director of the Department for the relations with MENA countries. At the present, I am the Director of the B4 Department for Bilateral Economic Relations with Southeastern Europe, Russia, the Caucasus, the Black Sea countries and BSEC issues.

I would like to start my presentation, by thanking Professor Dimitrios Mavrakis and the National and Kapodistrian University of Athens for inviting me to this great event.

I am really very excited being here today, participating in one of the activities of the National and Kapodistrian University of Athens, of great significance, as I have the honor to be a graduate of this University. Adjacent to this place, that we are now, is the historic building of the Law School of NKUA, where many years ago, I was gifted with the opportunity to be initiated to the science of law and where I spent four of the most interesting years of my life.

Dear Professor Mavrakis,

It is a pleasure, a challenge and a great opportunity for me, to be a part of this Conference, that you launched today and to join the very distinguished participants, from many countries, diplomats, high ranking officials of international organizations and of Government Agencies, scholars and scientists of a wide range of disciplines, market experts and professionals, in their joint endeavor to explore ways, to promote projects and enlist possible financial resources and investments, aiming at encountering some of the most serious challenges and threats that our planet is facing nowadays.

The issues of climate change, energy crisis, global economic recession and interruption of the normal functioning of the chains of food supply are not anymore just concerns related to future scenarios. They are the challenges we are facing today and the very heavy cost that their consequences entail for the well-being of our societies, is imposing onus the need for an effective response to these challenges.

This Forum is expected to offer the opportunity to an exchange of views, among others, on regional cooperation and synergies for Green Investment, and by using the accumulated experience in this field of certain participants, to explore the opportunities that regional cooperation for Green investment could provide for the implementation of projects and initiatives that could alleviate our societies from the aforementioned adverse developments.

Ladies and Gentlemen,

This conference is under the auspices of the Organization of the Black Sea Economic Cooperation, the BSEC. This reflects and signalizes, on the one hand the fact that climate change, Environment, Energy Security are among the fields where the BSEC unfolds its activities and on the other hand, that the Conference has a special focus on the wider area of the Black Sea, as the BSEC was launched thirty (30) years ago as a regionally owned initiative and it is continuing to be a genuine regional Organization of this region. The significance also that the Organization assigns to this conference, is reflected in the participation in the Conference of H.E the Secretary General of the BSEC, Ambassador Lazar Comanescu and the Deputy Secretary General, Ambassador Dimitrios Rallis, officials of the Organization and the Ambassadors of the member states of the BSEC in Athens.

The BSEC, was founded initially, in 1992, as a platform for dialogue and exchange of views at the highest level, in the wider region of the Black Sea and it was in 1996, due to the optimism, at that time, for a better World, with less division and conflicts and the prevailing enthusiasm for regional cooperation, the BSEC was transformed into a full-fledged, regional international organization.

Greece has lent its full support to the Organization since its establishment being one of its 11 founding member-countries. We value the Organization of the Black Sea Economic Cooperation (BSEC) as a genuine platform for regional cooperation in the Black Sea area.

Greece participates in all the activities of the Organization and has contributed to the efforts for keeping the Organization functioning, despite the enormous difficulties that recent disturbing developments entailed for the continuation of the operations of the Organization.

It was with great relief, that following our suggestion, with the support of other member states and with the kind acceptance of Moldova, the term of Moldovan Chairmanship was extended for one more semester, avoiding a major crisis in the Organization.

Greece is contributing annually, directly to the budget of the BSEC 245.000 euros, which makes Greece one of the four major financial contributors of the Organization, the other three being, Turkey, Russia and Romania. Meanwhile Greece is hosting two of the entities interrelated to the BSEC, the Black Sea Trade and Development Bank in Thessaloniki and the International Centre for Black Sea Studies in Athens, which is the think- tank of the Organization.

An important achievement of the BSEC was the establishment of cooperation with U.N. agencies the World Bank and other regional organizations. Greece has been a strong advocate, of the cooperation of BSEC with other organizations and more particularly for the cooperation of the BSEC with the European Union. The International Centre for Black Sea Studies, the ICBSS, which is based in Athens, plays an important role in the cooperation of the BSEC with the E.U. Many projects of the EU for the region are formulated/implemented with the active participation of BSEC Member States and PERMIS, with the latter taking part as lead partner in EU projects of millions of Euros, while the first ever Meeting between Ministers of Foreign Affairs of BSEC and EU States took place in Brussels in 2019.

As for the Black Sea Trade and Development Bank, it should be considered as an important element of the potential of the organization. During yesterday's dinner, Professor Mavrakis has made some very interesting remarks on the potential of this Bank to play an important role in Green Investment.

Ladies and gentlemen

I would like to conclude my remarks, by wishing to the participants of the Conference, the best of success, for the benefit of the citizens of our countries, for the benefit of the citizens of the whole world.

Short CV

Amb. Constantinos ORPHANIDES is the Director of B4 Directorate for the "Bilateral economic Relations with Southeastern Europe, Russia and the Caucasian and the Black SEA countries and the BSEC since 2020 up to present. Apart from Greek, he speaks English, French, Arabic, Spanish and Italian. He joined the Ministry of Foreign Affairs in May 1990.

Main points of Amb. Lazar COMANESCU's speech

BSEC – PERMIS Secretary General

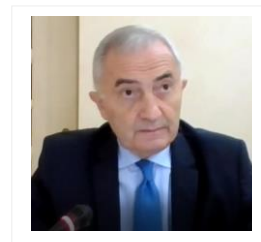

The Secretary General of BSEC PERMIS pointed out that the Forum is an important tool for the promotion of investments in clean energy and announced his intention to ask the member countries of the Organization to intensify their efforts for the green transformation of their economies and the development of policies to address Climate Change.

He concluded by underlining his decision to strengthen efforts to promote cooperation policies between the member states of the Organization, pointing out the positive role of the KEPA during its long-term cooperation with the member-states of the Organization and BSEC PERMIS, in this concept.

Short CV

Lazar COMANESCU graduated from the Foreign Trade Faculty of the Academy of Economic Studies (ASE) in Bucharest (1972). Then he followed a course on civilization and contemporary French language in Paris - Sorbonne (1973). In 1982, he obtained a PhD in international economic relations at ASE.

After graduation, he entered the Department of International Economic Organizations of the Ministry of Foreign Affairs (1972-1982). After obtaining his doctorate, he lectured at the Department of International Economic Relations of the Academy of Economic Studies (1982-1990).

After 1990, he returned to the Foreign Ministry, performing the functions of advisor and in 1993, minister-counselor at the Romanian Mission to the European Union - Brussels (1990-1994), Director of the European Union (1994-1995), general manager, advisor to the Minister of Foreign Affairs, director of cabinet (1995). In 1995 he was appointed as Secretary of State for Foreign Affairs (1995 to 1998) in the same period and associate professor at the ASE.

Since 1998 came a period of 10 years after Romania's diplomatic representation to the European Union, Ambassador Extraordinary and Plenipotentiary, Head of Mission of Romania to NATO and the EU (1998-2001), Ambassador Extraordinary and Plenipotentiary, Head of the Mission of Romania to the European Union the (2001-2007), Ambassador Extraordinary and Plenipotentiary and Permanent Representative of Romania to the European Union (2007-2008).

On 14 April 2008, he was appointed by decree as the Minister of Foreign Affairs (April 15th. - December 22, 2008). He was ambassador of Romania in Berlin (2009-2014). In February 2015 He was appointed presidential advisor, Head of Foreign Policy.

He is a member of the Scientific Advisory Board of the European Institute of Romania, member of the Scientific Council of the Romanian Institute of International Studies and a founding member of the Forum of Central Europe in Warsaw. In 2000, he was Awarded the National Order "Faithful Service" with the rank of Grand Officer. He is the author and coauthor of courses and textbooks including: 'The World Economy' (1985, 1990, 1995), 'International economic transactions Techniques' (1989), 'Dictionary of International Economic Relations' (1993).

Lazar COMANESCU held two mandates as Minister of Foreign Affairs, between April and December 2008 and from November 2015 to January, 2017. He was also Ambassador of Romania to Germany from 2009 to 2015 and head of the Romanian Representation to the EU from 2001 to 2008.

Main points of Amb. Andrei POPOV's speech

*Ambassador of the Republic of Moldova to the Hellenic Republic
Current Chairmanship-in-office of BSEC*



Amb. Andrei POPOV referred to the contribution of his country to the smooth operation of the BSEC by accepting the extension of the chairmanship of the Organization for a consecutive term. He mentioned the problems that have been created in his country by the war developments in Ukraine and the ongoing disruption in the security of its energy supply. Finally, he pointed out the need to be promoted policies related to tackling energy poverty in the region.

Short CV

He is currently the Ambassador of the Republic of Moldova in Greece and Cyprus. He is former Member of the Parliament (2009), Deputy Minister of Foreign Affairs and European Integration (2009-2013) and was Ambassador of Moldova to Austria, Slovakia, OSCE and International organisations in Vienna (2013-2016). In the later capacity, in April–August 2014, he served as the Chairperson of the OSCE's Forum for Security Cooperation (FSC). In 2016, in the middle of his ambassadorial mandate, he resigned from the diplomatic service in sign of disagreement with the policies of the ruling Democratic Party's leadership.

In 2004–2009, Popov was the executive director of the Foreign Policy Association of Moldova (APE) and founder of the Transnistrian Dialogues program. From 1997 to 2004, he served in different capacities in Moldovan diplomatic service: first in the Embassy of Moldova in Washington (1997-2001) as Second/First Secretary, then in the Foreign Ministry's General International Security Department (2001-2004) as its Deputy Director/Director.

He started his career in 1996 as Press and Information officer at the United Nations Development Program in Moldova.

Remarks by Prof. Asaf HAJIYEV

Secretary General of PABSEC



The Secretary General of PABSEC in his presentation pointed out that the further development of energy projects in the region will enhance energy security in Europe and beyond and will ensure better economic growth. Building regional cooperation and strengthening economic cooperation relations remains a priority for the countries of the region, which should unite efforts to ensure peace, stability and sustainable development.

Short CV

Dr. Asaf HAJIYEV was born in 1951. 2001-2015 was Professor and Chair of the Department of Theory of Probability and Mathematical Statistics at the Baku State University. In 2014 he was elected Academician (Executive member) of the Azerbaijan National Academy of Sciences, Institute of Control Systems.

He holds the Dr. Sci. degree from Bauman Moscow State Technical University (1992) and has done Ph.D. (1979) and post-doctoral research (1985-1989) at Lomonosov Moscow State University. He has vast research and teaching experience as the Chair of the department of Probability and Statistics, and of the Department of Controlled Queues, Institute of Control Systems at the Azerbaijan National Academy of Sciences; Chair of the Department of Theory of Probability and Mathematical Statistics, Baku State University; Senior Scientific Researcher, Department of Probability Statistics, Royal Institute Technology in Stockholm. Being a renowned researcher, he has served at the several universities around the world including China, Germany, Italy, Portugal, Sweden, Turkey, and USA. He serves on the editorial boards of many prestigious national and international academic journals. He has been an organizing member and the Keynote speaker at numerous international conferences. He has been honored with many prestigious awards like: Azerbaijan Lenin Komsomol Prize Winner on Science and Engineering; Grand Prize at the International Conference "Management Science and Engineering Management" Macao; and Grand Prize at the International Conference "Management Science and Engineering Management" at Islamabad, Pakistan.

He is the Honorary Academician of Academy of Sciences of Moldova, foreign member of the Mongolian National Academy of Sciences, Member of TWAS (The World Academy of Sciences), Honorary Professor of Chengdu university (China) and elected member of the International Statistical Institute.

He has also the honor of holding the office of the Vice-President and since 2015 the Secretary General of the Parliamentary Assembly of the Black Sea Economic Cooperation Organization. He serves on the boards of many international academic organizations and institution. He has more than 150 peer reviewed scientific publications to his credit, published in the highly reputed journals.

The 15th International Conference on “Energy and Climate Change”

Athens

12 October 2022

Mr. Asaf Hajiyev

Secretary General of the Parliamentary Assembly of the Black Sea
Economic Cooperation

The Black Sea region is rich in conventional fuels (oil, gas, coal, lignite), as well as alternative renewable energy sources, such as wind and solar energy.

The Trans Adriatic Pipeline (TAP) and the Trans-Anatolian Natural Gas Pipeline (TANAP) are very important energy routes, not only for the Black Sea Region, but for the whole Europe.

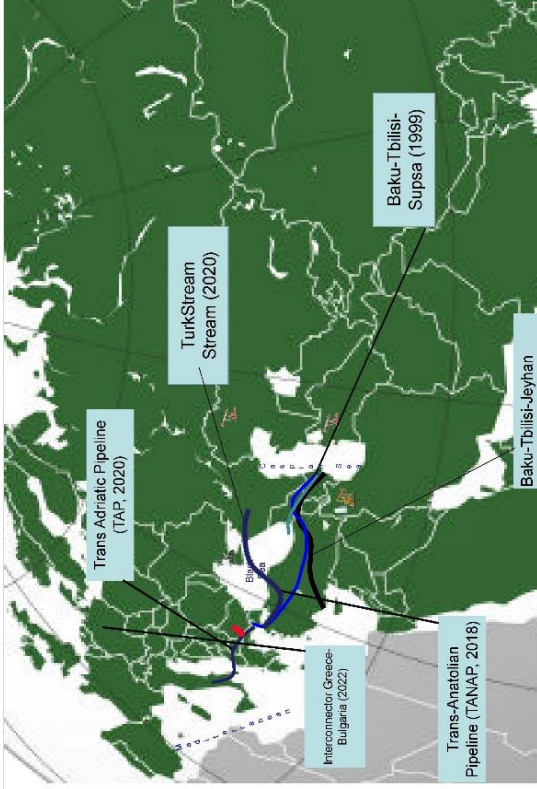

- On 1 October 2022, the launch of the **Interconnector Greece-Bulgaria (IGB)** was inaugurated at the opening ceremony in Sofia, Bulgaria.
- This event marks the end of the IGB construction, a key route to carry gas from the Trans-Adriatic Pipeline and Greece to Bulgaria and neighbouring countries (Albania, Italy).
- It is a crucial project for the diversification of gas supply in the South-East European region, a project of common interest and a priority project for whole Europe.
- The project, supported by the Trans-European Networks for Energy, has an initial capacity of 3 billion cubic meters/year (in the South-North direction) with an option for increasing the transmission capacity to up to 5 billion cubic meters/year with the construction of a compressor station on Greek territory.



The implementation of the **IGB project** aims to ensure diversification not only of the routes but also of the natural gas sources for Bulgaria and the wider region.

As part of the development of the Southern Gas Corridor, through IGB Bulgaria and its neighbouring countries will have access to alternative supplies from the Caspian region as well as from existing or planned **LNG terminals**. IGB will create new market opportunities and will enhance international cooperation and partnerships in the region.

IGB is being developed in a great synergy with the LNG terminal near **Alexandroupolis**, which is set for completion by the end of 2023.

With the terminal's implementation, IGB's capacity may see a significant boost of up to 5 bcm/y, which will further ensure the independent energy deliveries in the region, together with the deliveries of LNG from Qatar and the USA.

FSRU – Floating Storage Regasification Unit



Shah Deniz Stage 2 project is one of the biggest gas developments in the world and also a gateway to the Southern Gas Corridor that delivers natural gas from the Caspian Sea directly to European markets.

At plateau, Shah Deniz 2 will be produced 16 billion cubic meters of gas per year.

Together with output from the first phase of development, total production from the Shah Deniz field will be up to 26 bcm of gas and over 100,000 barrels of condensate a day.

The Shah Deniz commenced the delivery of significant new energy supplies to Europe, further diversifying its sources of energy and providing new supplies of natural gas which will be essential in the energy transition.

In future, gas from Turkmenistan through Caspian Sea and Azerbaijan can be delivered to Europe.

The Trans-Caspian interconnector project is expected to be implemented, which, according to preliminary estimates, will require investments of US\$400 million.

The basis for the implementation of the project will be the infrastructure already available in Turkmenistan and Azerbaijan in the Caspian Sea.

Meanwhile, the Trans-Caspian Interconnector will allow for the supply of Turkmen natural gas to Azerbaijan and further to the Transcaucasian region, Turkey and other countries. It will ensure the supply of 10-12 billion cubic meters of natural gas per year.

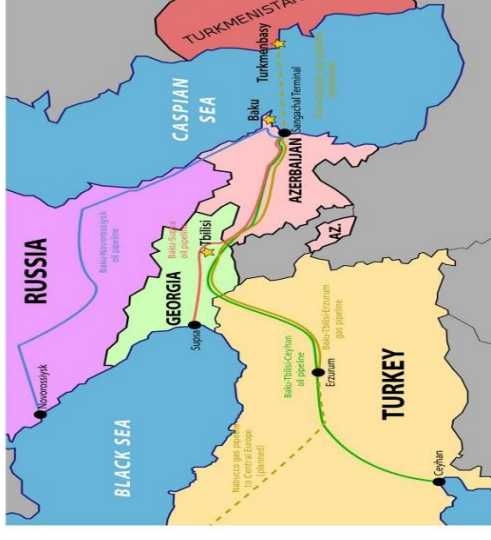

Renewable energy resources



- XXI century is the century of high technology, which contributes to the progress in the development of alternative energy resources.
- The electricity sector in the Black Sea region has gone through a significant transformation in the past decade.
- Many attractive incentives, such as Feed-in tariffs, Renewable Energy Zones, Green Certificates have been introduced to support the deployment of renewables in the region.
- Azerbaijan, Türkiye, Bulgaria, Romania, Greece as well as the other BSEC Member States have achieved significant progress in the development of renewable energy sources (wind, solar, hydro energy) due to their favourable location.
- Indeed, if rightfully exploited, the Black Sea untapped energy potential could actually serve as a bridge between today's use of resources and a future based on renewables.
- Such a transformation is not only a strong step to reach climate neutrality but also creates a transformation within the industrial development, by enhancing engineering skills, smart manufacturing chains and hi-tech solutions.



- The Black Sea countries envisage significant progress in the renewable energy potential.
- Turkey's installed wind energy capacity, for instance, stood at 9 GW as of January 2021. Meanwhile, there is an onshore wind potential of 37 GW and a completely untapped offshore wind potential of 11 GW.
- In order to reach its 2030 renewables target of 30.7%, Romania plans to add around 7 GW of new renewables capacity, of which around 3.7 GW is projected to be solar projects.
- Azerbaijan's renewable energy capacity is 4.5 MW out of a total 6.4 MW and the increase of the share of renewables in total electricity production is envisaged to 30% by 2030.
- At the end of 2019 Bulgaria pledged to update its national target for renewable energy and raised the share of wind, solar and other renewables to 27% of their energy consumption respectively by 2030.
- The 2018 National Energy Sector Strategy of Albania set up a target of 42% of renewable energy by 2030 which has already been achieved.

Concluding remarks

- In times of economic crisis, conflicts and insecurity, it is important to consolidate the cooperation among the BSEC Member States and join the efforts in solving the challenges that the region and the whole world is facing today.
- Conflicts and political insecurity affect the economic development and raise tension among the stakeholders.
- The further development of energy projects will strengthen the energy security in Europe and beyond and assure the better economic development of the countries.
- The green energy transition is technically feasible and economically beneficial, but requires substantial investments and innovations.
- Overall, the advantages of using renewable energy sources outweigh the disadvantages. Although the initial cost of establishing a network of renewable technologies might be higher, over time, the expenses will be offset.
- Building up regional cooperation and strengthening the economic potential remains a priority for the countries in the region, which should join efforts to ensure peace, stability and sustainable development.

THANK YOU FOR YOUR KIND ATTENTION

Speech of Amb. Burak ÖZÜGERGİN

Ambassador of Turkey to the Hellenic Republic



Mr. Deputy Secretary General,

Mr. Director,

Distinguished Ambassadors, Dear Colleagues,

The snapshot of our regional energy market is not reassuring at the moment. Demand is growing, while import dependency is causing havoc on our economies. The war in Ukraine brought to the surface a stark truth– that we need to address our import dependency, and we need to do it now. By the way, what a difference just one year makes – among the conclusions of last year’s Forum was that the energy sector was seriously affected by the pandemic, and that the pandemic was causing excessive supply and low demand.

The war took care of that. Now we are all scrambling to find alternative energy sources. But many of these alternatives, like increased LNG deliveries, are more like patchwork solutions for the moment. Even then, the critical challenge remains, and that is having to deal with the climate crisis. Therefore, while we address the most urgent tasks of today, i.e. finding energy to heat our homes and offices and factories and to operate our vehicles, it increasingly looks like turning to renewable sources of energy is no longer a luxury best left for the rich. The trick will be finding the correct mix and pace for the transition to renewables.

Speaking of renewables, Türkiye is fifth in Europe and twelfth in the world in terms of renewable installed power capacity, first in Europe and third in the world in geothermal energy, sixth in Europe in solar and wind energy, first among BSEC members and second only to Norway in Europe in hydropower, and lastly, first among BSEC members in biogas and bioenergy. We are now looking to hydrogen, given its potential role in achieving a sustainable energy future.

I am not throwing out all these rankings to feel good. But I do want to get the message across that we are actually implementing what we are preaching.

Dear colleagues,

Many renewable energy sources are weather-dependent to some degree. As our governments pursue the decarbonisation of energy systems, mainly through increasing levels of solar and wind power production, we need to ensure we have sufficiently robust and diverse sources of energy, including grid reliability to ensure secure supplies, including in case of extreme weather events.

The green transition will not happen overnight, as we will still need hydrocarbons to diversify our energy mix even after the transition. The eventual decommissioning of existing power generation structures, i.e. fossil fuel consumption, requires very careful assessment. We can ensure supply security and reduce dependency by investing in renewables as well as investing and cooperating in local and regional hydrocarbon projects.

To this end, we continue pursuing domestic hydrocarbon projects.

The discovery of 405 billion cubic meters in the Sakarya field in the Black Sea by the drillship Fatih in 2020 represents a milestone for the Turkish energy sector. A subsequent, second discovery was made in June 2021 of 135 bcm, which brought the cumulative gas find to 540 bcm. This amount can increase with further technical assessments of the location and its surrounding area.

But obviously, energy is more than thermal units and joules and watts. Energy is politics. Energy can bring together, and it can cause great friction. In an ideal world, each country would have sufficient natural resources to meet its energy needs. But we definitely do not live in an ideal world. Not even close. We therefore need to cooperate. We need to cooperate based on international law and within a spirit of good neighborliness.

Consequently, we in Türkiye are of the opinion that the most feasible solutions to energy questions in our region would be attained through inclusive policies. In that spirit, we are quite a dynamic player in the regional energy market. We are a large market as well as an energy hub.

For instance, you are all aware of the Trans-Anatolian Natural Gas Pipeline (TANAP), through which Greece and other connected countries receive Azerbaijani gas. As you know, TANAP is the backbone and comprises the longest stretch of the Southern Gas Corridor (SGC). It has certainly become crucial for Europe in these trying times. The good news is that TANAP's current transmission capacity of 16 billion cubic meters (bcm) of gas a year will be doubled in the period ahead.

In this regard, I want to underline once again that we want to see energy as a means of cooperation. There is nothing wrong with a little healthy competition, but this should not rise to the level of bitter rivalry or even hostility. Energy diplomacy should not entail zero sum games.

Ladies and gentlemen,

In any case, we are all in a race against time.

A race to become more energy sufficient and less energy dependent. At the same time a race to save our peoples from the adverse effects of climate change. The war shows us how far behind we fell, simply because we preferred business as usual over pursuing long-term goals. And the wildfires every summer for the last few years should be a wakeup call. There is simply no time to lose.

The quicker we realize that, the less painful our transition toward the new era will hopefully be.

Thank you.

Short CV

He started in 1985 his career as Attaché at the Department of International Economic Relations. For the period 1987 -1992 he served as Attaché at the Cabinet of the Minister of Foreign Affairs and at the Turkish Embassy in London as Attaché, Third and Second Secretary. He was the Vice-Consul, Turkish Consulate General in Benghazi for the period 1992-1994. He joined the Cabinet of the Undersecretary of the Ministry of Foreign Affairs as Second and First Secretary from 1994 to 1996. In 1996, he was positioned at the Permanent Mission of Turkey to the United Nations as First Secretary and Counsellor. He became the Chief of Section, Acting Head of Department of Maritime Affairs in 2000. For the period 2003 –2007, he was Counsellor, First Counsellor at the Turkish Embassy in Washington. In 2007 he was Head of Department, European Union Affairs and in 2008 under the Minister of Plenipotentiary, he was the Head of Information at the Department and Foreign Ministry Spokesperson. From 2010 up to 2018 he served as Ambassador of the Republic of Turkey to Croatia, Director General for Bilateral Political Affairs and Acting Deputy Undersecretary for Bilateral Political Affairs. He is the Ambassador of Turkey at the Hellenic Republic since 18.12.2018.

Speech of Amb. David DONDUA

*Ambassador Extraordinary and Plenipotentiary of Georgia
to the Hellenic Republic*

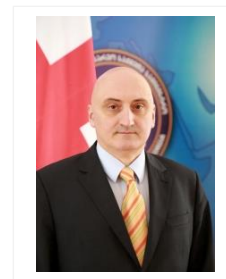

Dear colleagues,

Today we are brought together to exchange views and share initiatives on how renewable energy and low-carbon alternatives can help countries to achieve sustainable economic development and materialize the long-term vision of transforming the wider Black Sea Region into a model for clean energy.

This forum is an excellent opportunity to share information on the best practices and challenges in the area of renewable energy, discuss the latest developments in the global energy market, including perspectives on clean energy.

From the onset, I should note that peace and stability in our region is key for the regional development and lasting prosperity, but challenges persist. Our region continues to face multiple challenges – political, economic and global pandemic are just a few to name. Altogether, regrettably, these challenges adversely affect the fragile situation and harm the peaceful development of our region.

Georgia is particularly concerned with the efforts by the Russian Federation to redraw the European security architecture and undermine the principles of international law in our neighbourhood and beyond. We see well-reported pattern with military aggressions in Georgia and Ukraine as extremely dangerous for world peace with immediate repercussions for our shared region.

These developments in the region have adverse effects on energy security, contributing to enhanced energy insecurity, forcing Governments their energy sources. Thus, renewable energy plays an important role in supporting energy security as it can address environmental as well as security objectives.

In order for governments to obtain greater security of energy supply, and to help meet their climate change policy targets, greater uptake of more energy efficient technologies, demand reduction, and adding more renewable energy systems to the national portfolio make good sense. Security of energy supply should be a key objective of governments if they are to meet other objectives relating to economic growth.

To this end, in close collaboration with our partner countries, Azerbaijan and Türkiye, we are deepening regional cooperation on energy security issues, based on our common interests and shared vision on global security. We are going to further support expansion of hydrocarbon and electricity supply chains from the Caspian Sea to the European Market, since diversification of energy sources remains an important issue for the countries of the South Caucasus and the EU.

It is well known that our transit corridor, has proved itself as a reliable link, in more than two decades old, regional cooperation in delivering hydrocarbon resources together with our partner countries Azerbaijan and Türkiye via the West Route Export Pipeline (WREP), Baku-Tbilisi-Ceyhan Oil, Baku-Tbilisi-Erzurum Gas Pipelines and Southern Gas Corridor which has been a tremendous success thus actively contributing to the Energy security of the European Union. Geopolitical context, in particular international sanctions imposed on Russian Federation, has further boosted our role as an essential transit channel.

Investments in Green Energy are crucial for the modernization of the energy sector and for achieving the SDG 7 Goal and, more generally, for economic growth, job creation and increasing energy security.

Taking into account Georgia's commendable potential in renewable energy sources, we aim at becoming regional leader in green energy production. Georgia has substantial capacity for power generation from renewable energy sources to supply not only internal market, but also neighbouring countries (only up to 27% of the hydro potential s utilized). In this regard, I would invite Greek

energy companies to visit Georgia, explore business opportunities and expand business activities in Georgia.

GoG is working with the partner countries to develop the Black Sea Submarine Cable Georgia - Romania project connecting South Caucasus Region directly to the South-East Europe via submarine cable crossing Black Sea. The World Bank has prepared a report on Preliminary Economic Analyses of the Project and proved that it is economically viable. Project will support development of renewable energy sector, increase transit opportunities/back-to-back trade options between the EU and South Caucasus Region.

Let me once again reaffirm the commitment of my government to the implementation of the SDG 7 Goal to ensure access to affordable, reliable, sustainable and modern energy for all.

It should be mentioned, that within the framework of the Paris Agreement and EU-Georgia Association Agreement, Georgia has set ambitious plans to achieve climate change mitigation and green economy development.

This year, Georgia signed agreements with Switzerland and Japan on emissions trading. This will help Georgian, Japanese and Swiss companies to implement joint projects in various fields, including renewable energy - hydro and solar power plants, power generating equipment, devices, ways of generating energy from waste, and the most energy-efficient transport systems.

I believe that access to carbon markets will help Georgia to implement its climate agenda, obligations set forth in the International Agreements.

BSEC Member states should act with greater speed for decarbonizing the energy sector and for implementing the targets of the Paris Agreement, by creating a favorable administrative and legal climate framework for Green Investments and intensify efforts to explore possibilities to finance Green Energy projects in the region.

Efficient coordination and active collaboration among BSEC Member States and between the public and private sectors is essential if renewable energy technologies are to be successfully developed to help meet the goals of sustainable development and climate change mitigation, as well as to reduce the risk of continuing disruptive energy supplies.

In conclusion, let me underline that Georgia is determined to maintain intensive efforts with Member States and support all the proposals aimed at further sustainable development of the Black Sea region.

Thank you.

Short CV

Amb. David DONDUA was appointed as Deputy Foreign Minister in November 2014. He is in charge of policy planning, security policy, conflict resolution and bilateral relations with neighbouring countries. He leads Georgian delegation at Geneva International Discussions and chairs State Commission on delimitation and demarcation of state borders. Prior to his current assignment David Dondua served as First Deputy State Minister for European and Euro-Atlantic Integration (2012-2014) and Chief of Cabinet of the Chairman of Parliament of Georgia (2008-2012). He is a career diplomat. He joined the Ministry of Foreign Affairs in 1993 and held different position in the capital as well as abroad, including Deputy Chief of Mission at the Embassy to US and ambassador to NATO. David Dondua is also associated professor of Tbilisi Open University and guest lecturer at Tbilisi State University. Before joining Foreign Service, he worked as an assistant professor at the Institute of Geography of the Academy of Sciences of Georgia and was deputy director of Tbilisi #6 Gymnasium. Amb. David Dondua is founder member of Georgian Oral History Association and member of scientific council of Geographic Society of Georgia.

Main points of Amb. Jakub KARFIK's speech

*Ambassador of the Republic Czech to the Hellenic Republic
- Presidency of the EU Council*

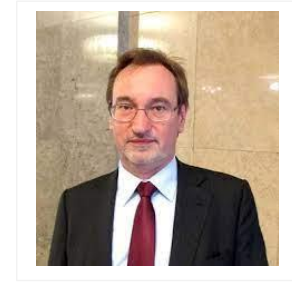

The Ambassador of the Czech Republic to the Hellenic Republic referred to the EU policies related to the developments in the war in Ukraine, the issues of the economic recession and especially the issues related to the Security of Energy Supply in the EU countries and pointed out the need for international and regional cooperation to address these problems.

Short CV

On 26 May 2020, Amb. Jakub KARFIK presented the Letters of credence to the President of the Hellenic Republic Mr. Katerina SAKERALLOPOULOU, accrediting him as Ambassador Extraordinary and Plenipotentiary of the Czech Republic to the Hellenic Republic. He joined the diplomatic service in 1995.

Speech of Amb. Amrit LUGUN

Ambassador of the Republic of India to the Hellenic Republic



Prof. Dimitrios MAVRAKIS, Amb Lazăr COMĂNESCU, Prof. Asaf HAJIYEV, Amb. Dimitrios RALLIS, my fellow Ambassador colleagues, other members of the Diplomatic Corps, experts on energy present here,

Ladies and Gentlemen,

I would like to thank the organizers of the 9th Annual Green Energy Investments Forum for inviting me as representative of my country, India to share what my country has been doing on “energy and climate change” in the global and regional context.

India is now the third largest energy consuming country in the world. The country has set an ambitious target to achieve a capacity of 175 GW worth of renewable energy by the end of 2022, which expands to 500 GW by 2030. This is the world's largest expansion plan in renewable energy.

India was the second largest market in Asia for new solar PV capacity and third globally (13 GW of additions in 2021). It ranked fourth for total installations (60.4 GW), overtaking Germany (59.2 GW) for the first time.

The country's installed renewable energy capacity has increased 396% in the last 8.5 years and stands at more than 159.95 Giga Watts (including large Hydro), which is about 40% of the country's total capacity (as on 31st March 2022). The installed solar energy capacity has increased by 19.3 times in the last 8 years and stands at 56.6 GW as of 1st June 2022. The installed Renewable energy capacity (including large hydro) has increased from 76.37 GW in March 2014 to 159.95 GW in May 2022, i.e. an increase of around 109.4%.

Government of India has set targets to reduce India's total projected carbon emission by 1 billion tonnes by 2030, reduce the carbon intensity of the nation's economy by less than 45% by the end of the decade, achieve net-zero carbon emissions by 2070.

The Indian Renewable Energy Development Agency Limited (IREDA), has committed to take forward the Hon'ble Prime Minister of India's vision of complete solarisation of at least one city in each State of India and to participate in “One Sun, One World and One Grid” Plan. Till 2021, IREDA has finalised close to 3000 renewable energy projects in India and has supported green power capacity addition of close to 18000 megawatt in India. The Organisation is committed towards Government of India's common goal to ensure access to affordable, reliable, sustainable and green energy for all, while always keeping the citizens at the centre of this transition.

At the regional level, the South Asian Association for Regional Cooperation (SAARC), of which India is a member, a Framework Agreement for Energy Cooperation (Electricity) has been signed on 27 November 2014 for promoting cooperation and transmission of energy in the region, including production and sharing of renewable energy. Cooperation and linkages with other regions of ASEAN lying to the east, and Middle East and Gulf lying to the west, in energy are also taking place through various plans and alliances, including exploring the possibilities at sub-regional level. For example, transmission of surplus hydro-electric energy from Nepal and Bhutan, two countries rich in hydro-electric power potential, through India to Bangladesh. In addition, energy cooperation is part of cooperative activities of Bay of Bengal Initiative for Multi-Sectoral Technical and Economic Cooperation (BIMSTEC), another regional organisation, of which India is a part.

At the global level, on the sidelines of the 21st Conference of Parties (COP21) to the United Nations Framework Convention on Climate Change (UNFCCC) held in Paris in 2015, India, jointly with France, launched the International Solar Alliance (ISA). ISA is an action-oriented, member-driven, collaborative platform for increased deployment of solar energy technologies as a means for bringing energy access, ensuring energy security, and driving energy transition in its member countries.

The ISA strives to develop and deploy cost-effective and transformational energy solutions powered by the sun to help member countries develop low-carbon growth trajectories, with particular focus on delivering impact in countries categorized as Least Developed Countries (LDCs) and the

Small Island Developing States (SIDS). Being a global platform, ISA's partnerships with multilateral development banks (MDBs), development financial institutions (DFIs), private and public sector organizations, civil society and other international institutions is key to delivering the change it seeks to see in the world going ahead.

The ISA is guided by its 'Towards 1000' strategy which aims to mobilise USD 1,000 billion of investments in solar energy solutions by 2030, while delivering energy access to 1,000 million people using clean energy solutions and resulting in installation of 1,000 GW of solar energy capacity. This would help mitigate global solar emissions to the tune of 1,000 million tonnes of CO₂ every year. For meeting these goals, the ISA takes a programmatic approach. Currently, the ISA has 9 comprehensive programmes, each focusing on a distinct application that could help scale deployment of solar energy solutions. Activities under the programmes focus on 4 priority areas – Analytics & Advocacy, Capacity Building, Programmatic Support, and readiness and enabling activities, that help create a favourable environment for solar energy investments to take root in the country.

The International Solar Alliance Secretariat has been set up in Gurugram, near Delhi for the purpose. India has provided support worth US\$ 27 million towards hosting the ISA secretariat, created an ISA corpus fund, offered training support for ISA member countries at National Institute for Solar Energy (NISE) and also provided support for demonstration projects for solar home lighting, solar pumps for farmers and for other solar applications. Apart from contributing to ISA Corpus Fund, India contributed US \$ 62 million for the establishment of ISA Secretariat. Additionally, India is providing 500 training slots in solar energy to the ISA members every year and have either completed or are implementing 13 solar projects worth US \$ 143 million worldwide. India is offering \$ 1.4 billion in assistance to 27 other projects in 15 other developing countries. 90 countries have so far signed and ratified the ISA Framework Agreement, including Greece, which joined the Group in June 2021.

During her visit to India from 24-25 April 2022, as the President of the European Commission, H.E. Ms. Ursula Von Der Leyen, made the following comments in her statement: "I spent an exciting day at the International Solar Alliance. Energy security is one of the most pressing topics for India as well as Europe. The EU will diversify away from fossil fuels and will invest heavily in clean renewable energy. Therefore, cooperation with India not only on solar but also on green hydrogen is critical."

In the context of what is currently going on globally, energy security, especially renewable energy, has gained considerable importance, both for development and environment. I hope that the 15th International Scientific Conference with focus on Black Sea Economic Cooperation Region (BSEC) will be able to come out with a roadmap for promoting energy security. With the goals, commitments, and activities India has undertaken, both regionally and globally, on the subject, collaborating with India and its region could be planned/undertaken.

Short CV

Amb. LUGUN served as Desk Officer for India Technical and Economic Cooperation Programme in the Ministry of External Affairs from July 1993 to June 1995. He was a Second Secretary, Embassy of India, Doha, Qatar from June 1995 to September 1998. He served as First Secretary at the Embassy of India, Paris, France from October 1998 to December 2001. During his time in Paris, Lugun was accused of beating and sexually abusing Lalita Oraon, his family's live-in servant. The case would cast a shadow on France-India relations.

After Paris, Lugun was First Secretary at the Embassy of India, Algiers, Algeria from January 2002 to August 2004. At the Ministry of External Affairs from September 2004 to December 2008, he was a Director in the territorial divisions of Eurasia and Latin America. From March 2009 to September 2010, he was posted to the Indian Embassy, Manila. He then served as Director in the SAARC Secretariat in Kathmandu, Nepal. Later he was Ambassador of India to the Republic of Yemen and then Joint Secretary of Consular, Passports and Visas at Ministry of External Affairs.

He is the Ambassador of India to Greece since 29 July 2020.

DAY 1: 9th Green Energy Investments Forum

Session 2 – Symposium (Working lunch)

The 1st BSEC-GEN and BSEC-PERMIS Symposium

The Symposium was held, for the first time, with the participation of their Excellencies, the Secretary General and the Deputy Secretary General of PERMIS, the Ambassadors of Moldova and Georgia from the troika of the BSEC-Chairmanship-in-office, the Secretary General of the Parliamentary Assembly of the Black Sea Economic Cooperation (PABSEC), the BSEC-GEN Coordinator and members of the network from Albania, Azerbaijan, Moldova, Serbia and Greece.

The Symposium provided the opportunity for a sincere exchange of views between the participants on the problems and the potential of the network to promote cooperation on issues of common interest.

The university professors of the BSEC - GEN underlined their efforts to support the BSEC policies especially in the fields of Energy Efficiency, in identifying and overcoming behavioral obstacles in implementation of policies and concluded with their efforts to convince BSTDB to get involved in developing and implementing bankable projects against energy poverty.

They informed BSEC PERMIS, that members of the network have benefited by the EU Horizon financing procedures and underlined the need to continue and enhance the cooperation with partners from BSEC Member States. They have organized seminars and meetings in almost all BSEC – MS and have participated to all calls for proposals made by BSEC.

In this context, it was discussed the perspective for a joint action to address the problems of energy poverty, in cooperation with the member countries of the Organization in the framework of a "Structured Policy Dialogue" that the BSEC – GEN and its members have the potential to conduct.

The Symposium ended with a statement made by the Secretary General of BSEC PERMIS that these issues will be introduced at the next meeting of the Working Group on Energy of the BSEC - MS.

The works of the 9th Green Energy Investments Forum were funded by the Hellenic Green Fund of the Ministry of Environment and Energy (Financial Program "Financial support for extrovert actions 2022").

Address by Prof. Andonaq LONDO LAMANI

Technical University of Tirana, Albania



Good morning, Ladies and Gentlemen,

I would like to start by thanking the organizers of this event and especially Professor Mavrakis for the invitation to me to participate in the 9th Green Energy Investments Forum and the 15th International Scientific Conference on Energy and Climate Change.

It is a great honor to be among such distinguished personalities during this important event. It really offers a great opportunity to discuss and be informed about developing projects and ways of investments that will assist the economies of the BSEC Member States to acquire a more “green identity”. This event, besides its importance both for the business and scientific worlds, gives us the possibility of addressing an important subject – climate change, which is not anymore treated like a national issue. The subjects of energy and climate change found a honorable place in the agendas of countries, regional and international organizations.

Briefly I want to present here some objectives of the Albanian government regarding one of the main dimensions of the energy union which are Climate action, renewable energy and the decarbonization of the economy. Certainly, the Albanian government is preparing all the legal documents about other priorities such as energy security; internal energy market; energy efficiency and research innovation on competitiveness.

Albania has a considerable potential of Renewable Energy Sources (RES). The use of such sources for energy production represents a long-term strategy for implementation of three objectives of energy policies of the country, such as: i) support for the overall economic development; ii) increase of the security of energy supply and iii) protection of environment. Albania committed to a binding 38% target of energy from RES in gross final energy consumption in 2020, starting with 31.2% in 2009. In 2015, according to the energy balance published by EUROSTAT, Albania achieved a 34.9% share of energy from RES, above the third indicative trajectory of 34.3%. Thanks to the favorable geographic position in the Mediterranean Sea Basin, Albania has significant potential of RES such as, water, wind, sun, biomass and geothermal.

The reasons for investing in RES at Albania are the following:

- The Government in its General National Plan “Albania 2030” has set Renewable Energy as the key priority, for developing a “Green Energy”- driven economy;
- Incentives, governmental support and facilitation of investments;
- High-quality experienced engineering and technical workforce, particularly in the hydropower sector;
- Proven record of successful foreign investments in the sector.

The implementation of the RES Strategy will increase the security of Albania’s energy supply and begin to integrate the Albanian energy market into regional, the Energy Community and the European markets.

Hydroelectric energy

Albania has a Huge Potential for Hydroelectric Energy. Water resources are among the most important natural resources in Albania. The major rivers and hundreds of smaller rivers and streams as well as the hydrographic territory of Albania of about 700 m above sea level, offer a considerable potential for investments. Only 35% of hydroelectric energy potential is currently being utilized.

Wind energy

Albania has an unexploited wind power potential, especially along the Adriatic Coast where many areas with high wind energy potential are located. The main part of the territory (app. 2/3 of the

whole surface) is hilly and mountainous (east of the country). The coastline is in the direction of North-South. The overall potential of wind energy that may be produced through wind parks has been estimated at more than 2,000 mW. In the next five years the Government of Albania aims to generate 5% of total electricity from the wind sources.

Solar energy

Within the territory of Albania, we have a considerable potential of solar energy, where many of its areas are exposed to a radiation that reaches from 1185 kWh/m² per year up to 1700kWh/m² per year. On clear weather, every square meter of the horizontal surface of this area may absorb around 2200 kWh per year.

Petroleum and gas energy

Albania has a significant volume of oil reserves, producing more than 1.4 million ton/year. International oil & gas exploration companies are already established in Albania. The Albanian oil, gas and by products market is a free, open, and liberalized market and the Government of Albania plays only a regulatory role.

Consequently, as I mentioned above, there is a strong interest in the energy sector to attract new workforce and to attract new investments from local and foreign business.

Thank you for your attention!

Short CV

Full professor at the Energy Department since 1980. He teaches Energy Efficiency; Fluid Mechanics, Fluid Machinery; Internal Combustion Engines, Fluid Power. He is currently the Executive Director of the SEEIESD (South East Europe Institute for Energy and Sustainable Development). Starting from August 2019 he is the National Contact Point for HORIZON 2020 "Secure, clean and efficient energy". His main research interests are in the field of Energy and Climate Change etc. He was the leader of projects funded by the European Union (FP7; TEMPUS) in the field of renewable energies and energy efficiency as well as in projects funded by the Albanian government (Program for Water and Energy 2007 - 2017). Information at: <http://www.seeiesd.org/>.

Intervention of Dr. Mihai TIRSU

Director of Institute of Power Engineering, Moldova



All of us know very well that energy poverty is a widespread problem across Europe, as between 50 to 125 million people are unable to afford proper indoor thermal comfort. At the end of year 2021 along with the COVID-19 pandemic and the related health crisis, the Republic of Moldova faced a significant increase of the gas prices as a consequence both of the very tight global energy markets and the amended contract with its gas supplier – Gazprom. This situation has had a significant negative impact not only on Moldova's economy, but on the ability of the most vulnerable households to afford gas throughout the winter period. This problem became more stringent after the Russian war against Ukraine, which resulted in a huge higher price on gas and electricity. The gas price increased about 7 times compared to that of the same period a year ago, that respectively resulted in a tariff increase for electricity, as it is produced from the same gas procured from Russia.

At national level, there are several approaches to define energy poverty: those provided by the regulatory and policy framework, but also those used in the analysis of absolute poverty and living standards of the population. Even if energy poverty is not defined in the social protection legislation, the Aid for the cold period of the year is granted simultaneously with the Social Aid poverty benefit as an instrument of supporting households during the five cold months (from November to March), when they are most vulnerable under the energy perspective. There are also other compensatory mechanisms designed and regulated to reduce the effects of rising energy tariffs on vulnerable groups, such as: i) financial assistance for energy recourse mechanism implemented by the Chisinau municipality; ii) on-bill compensation mechanism introduced by the Government at the end of 2021.

According to the Household Budget Survey data (HBS), the expenses for energy in 2020 were classified in the second place according to their importance, following the expenses for food products and non-alcoholic beverages. The energy use pattern differs among areas of residence in Moldova. Thus, the energy sources with the higher share of the urban households' expenses are electricity and network-supplied gas, while the rural households spend more on wood, logs, sawdust, etc. and electricity. In general, rural households have lower expenses, as the total monthly average consumption expenditures account only for 2/3 (66%) when compared to those of the urban households, while the energy expenditures in villages represent almost 90% when compared to those registered by urban households.

Consequently, of both COVID-19 and energy crisis, the national poverty in 2020 raised to 26,8% and extreme poverty raised to 10,8% (almost twice compared to that of year 2015). Now, after the Russian war against Ukraine the figures became much higher. So, for facing Moldova's energy poverty and for all countries members of the Black Sea Economic Co-operation Organization (BSEC) that are facing the same problem, we need to find a specific approach to solve this problem. I consider that Green Energy Investments Forum 2022 is the right platform to identify useful instruments, commercially viable to solve in the future this very important problem. In this context I support the involvement of BSTDB and the development of an appropriate financing tool to overcome problems related to energy poverty.

For Moldova energy efficiency is also an important issue to be solved, as Moldovan consumers are paying a lot for energy due to high heat losses of their buildings. Here dedicated programs/projects are needed to increase our energy efficiency, as currently we have 3 times higher energy intensity compared to the average level of EU. Also, regional cooperation in development and implementation of best available technologies is good opportunity to reduce energy poverty and to increase income of people.

Short CV

Mr. Mihai TIRSU is a Dr. of technical sciences and has an experience of over 25 years in the energy sector. Currently he holds the position of Director of the Institute of Power Engineering of the Moldova, which is the only public research institution in Moldova and provides scientific support to the Ministry of Infrastructure and Regional Development (Government) in developing and implementing strategic documents in the energy sector such as: Energy Strategy of Moldova 2030, Energy balance forecast for short-term and long-term, National Energy Efficiency Plan, Electricity law, Energy Efficiency law, Renewable Energy law, etc. He has vast experience both as manager of international and national projects and as an executor. Also, he has experience as an expert in several key projects in Moldova financed from European funds. The main research activities are related to studies for developing different scenarios for interconnection of power system of Moldova with ENTSO-E, elaboration of measures directed to strengthening and development of energy system, modelling of power system operation regimes, developing future scenarios, analysis of power plant development both traditional and renewable, elaboration of recommendations for balancing the energy system in case of increasing intermittent generation sources (renewable), developing innovative equipment for directing the flow of power in transmission network. Results of research activities are provided in more than 190 scientific papers and patents.

Address by Prof. Dejan IVEZIC

University of Belgrade, Serbia

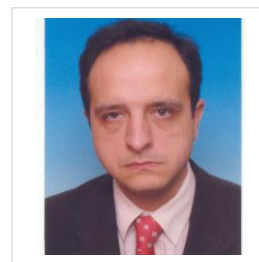

Discussion related to the possibilities of regional cooperation and the creation of projects related to energy poverty and energy efficiency.

The problem of energy poverty in Serbia has existed for years, but in the previous period, it was not considered separately from poverty in general. However, the significant increase in energy prices put this problem in focus. In 2021, energy poverty was finally officially defined as "a state in which the household does not have sufficient opportunities to provide the necessary energy necessary for a healthy and dignified life in a way that does not endanger other basic household needs or wider community".

Energy poverty is reflected in the impossibility of purchasing and paying for energy or fuel (electricity, natural gas, firewood) or in the use of environmental and health-unacceptable materials for energy needs (waste, old tires, used motor oil, etc.). Energy poverty is most evident during the winter season and is related to the heating of living spaces. Initial research indicates that the problem of energy poverty is largely related to the problems of inefficient buildings – single and multifamily houses and apartments, as well as the use of inefficient heating devices. Energy consumption in households in Serbia is mostly related to the traditional use of firewood (almost 50%) in low-efficiency stoves and ovens. Although carbon neutral, this method of heating is unacceptable from an environmental point of view due to the significant emission of local pollutants. Inefficient heating systems and poor insulation of buildings result in poor households consuming a disproportionately large amount of energy, and heating is very often limited to only one room in an apartment or house.

Overcoming the problem of energy poverty is not easy, but it is possible. It is necessary to provide sustainable financing models for the energy rehabilitation of buildings and the purchase of more efficient heating devices. It is worth thinking about the concept of the prosumer, i.e. about the possibility for households to produce part of the required energy themselves and/or exchange it with the power system. In this sense, positive experiences from the region can be very significant.

One of the acceptable concepts is the formation of a joint regional fund to combat energy poverty. Given that energy-poor households are not creditworthy, the regional fund would lend to local self-governments, which would then allocate funds to increase energy efficiency in households through energy rehabilitation of buildings and the purchase of more efficient and environmentally friendly heating devices. The achieved savings in energy and money would represent resources that would serve to repay the loan and achieve the sustainability of the entire financing mechanism.

Short CV

Professor at the University of Belgrade – Faculty of Mining and Geology and Manager of Centre for Energy, where His teaching and research interests include energy modeling and control of energy processes, sustainable development, energy efficiency and renewable energy sources utilization and conservation of natural resources. He also, directed and cooperated in projects related to exploitation and maintenance of energy facilities, machines and equipment.

Conclusions

The works of the 9th annual Green Energy Investments Forum, held on 11 and 12 October 2022, were successfully completed. It aimed to promote Green Investments in the countries of the Black Sea Economic Co-operation Organization (BSEC). The Forum was organized by the KEPA, in its capacity as coordinator of the BSEC Green Energy Network (GEN) and under the auspices of BSEC.

The 4th annual Dinner

The 4th annual Dinner is provided every year on the eve of the Forum in honor of the ambassadors of the BSEC Member States. The event was attended by the Secretary General and the Deputy Secretary General of PERMIS - BSEC, the Secretary General of the Interparliamentary Assembly of the Black Sea Countries (PABSEC), the Ambassador of Moldova, the country holding the current Chairmanship-in-office of BSEC, the Ambassador of the Czech Republic, the country exercising the Presidency of the Council of the EU, the Ambassador of India, invited country to the Forum, the representatives of the Hellenic Ministry of Foreign Affairs, the Ambassadors of Albania, Bulgaria, North Macedonia, Georgia, Turkey, Ukraine, the President of the Hellenic Regulatory Authority for Energy (RAE), members of the Hellenic energy market, KEPA and consultants.

The participants of the Dinner were addressed by the Director of KEPA and coordinator of the Network (BSEC – GEN), who referred to the need for the countries of the Organization to instruct their representatives in the Board of Governors of the Black Sea Trade and Development Bank (BSTDB) to expand its activities so as to address Energy Poverty among the societies of BSEC Member states.

The Secretary General of PERMIS underlined the opportunity, provided by the Forum, to ambassadors of the member states and to PERMIS for an exchange of views on how to promote cooperation on the issues of green investments.

He expressed the appreciation of PERMIS to the KEPA and its Director for their long-lasting contribution to the regional cooperation on the issues of green energy and climate change.

He stressed the need to strengthen cooperation actions in the particularly difficult circumstances prevailing in the region. Finally, on the subject of energy poverty, he pointed out that although he supports the initiative, the possibilities of PERMIS are limited and that this is a matter of Member States and BSTDB.

H.E the Ambassador of Moldova, informed the attendees about the developments in his region and the negative impacts on his country, while regarding the proposal of the KEPA, tackling energy poverty, with the involvement of BSTDB and the development of an appropriate financing tool, he said that the issue is already being discussed by the relevant services in his country.

The 9th annual Forum

The participants of the Forum were addressed by the Secretary General of the Permanent International Secretariat (PERMIS), the Secretary General of the Interparliamentary Assembly of the Black Sea countries (PABSEC), the representative of the Hellenic Ministry of Foreign Affairs, the Ambassador of Moldova, the ambassadors of Albania, Bulgaria, North Macedonia, Georgia, Ukraine, Turkey, the Czech Republic (a country exercising the current presidency of the Council of the EU) and India, the guest country, who presented their policies on the forum's issues.

In particular, the Secretary General of PERMIS pointed out that the Forum is an important tool for the promotion of investments in clean energy and announced his intention to ask the member countries of the Organization to intensify their efforts for the green transformation of their economies and the development of policies to address Climate Change.

He concluded by underlining his decision to strengthen efforts to promote cooperation policies between the member states of the Organization, pointing out the positive role of the KEPA during its long-term cooperation with the member-states of the Organization and PERMIS, in this concept.

The Secretary General of PABSEC in his presentation pointed out that the further development of energy projects in the region will enhance energy security in Europe and beyond and will ensure better economic growth. Building regional cooperation and strengthening economic cooperation relations remains a priority for the countries of the region, which should unite efforts to ensure peace, stability and sustainable development.

The Ambassador of Moldova referred to the contribution of his country to the smooth operation of the BSEC by accepting the extension of the chairmanship of the Organization for a consecutive term. He mentioned the problems that have been created in his country by the war developments in Ukraine and the ongoing disruption in the security of its energy supply. Finally, he pointed out the need to be promoted policies related to tackling energy poverty in the region.

The Ambassador of Turkey referred to the negative effects of the pandemic and the war in Ukraine, the security of energy supply for the countries of the region and the role of LNG. He referred to the role of existing intercontinental natural gas pipelines and especially those passing through Turkey to address these problems. He referred to Turkey's participation in global efforts for the green transition and underlined the importance of Turkey's discovery of the Sakarya deposit in the Black Sea, with a total capacity of 540 bcm.

The Ambassador of the Czech Republic referred to the EU policies related to the developments in the war in Ukraine, the issues of the economic recession and especially the issues related to the Security of Energy Supply in the EU countries and pointed out the need for international and regional cooperation to address these problems.

The Ambassador of India presented his country's policies and actions on energy and climate change issues on a global and regional scale. India is the country with the third largest energy consumption on the planet. To meet its needs, it implements the largest RES program on a global scale with the aim of building 500GW by 2030. India has developed a wide network of regional and international cooperation that extends from the countries of South Asia, the Middle East, the Gulf and of course the EU, especially France.

The Government of India has set a target of reducing carbon emissions by 1 billion tons by 2030. To achieve this goal, it plans to mobilize investments of USD 1trillion, through the International Solar Alliance (ISA), while it aims to achieve zero carbon emissions by 2070.

The Director of KEPAC and coordinator of the BSEC - Green Energy Network, referred to the expected increase in energy poverty in all countries of the Organization and the urgent need to develop and implement programs to address it with the active involvement of BSTDB.

These programs can be developed with the creation of an appropriate financing tool by the BSTDB aimed at issuing and managing guaranteed bank loans on the basis of a "Structured Political Dialogue" that will be carried out under the coordination of KEPAC, the involvement of potential beneficiaries, local authorities (municipalities), commercial banks and the construction sector.

He stressed out that his proposal meets the BSTDB's requirements for bankable projects with guaranteed margins of profit and concluded with an appeal to BSEC-Member States to support his proposal through their Governors to the BANK, as soon as possible.

DAY 2: Scientific Sessions

Opening speech by Prof. Dimitrios KARADIMAS

Vice Rector of the National and Kapodistrian University of Athens, Hellas

Dear colleagues

On behalf of the National and Kapodistrian University of Athens, the oldest and most prominent Greek university, I cordially welcome you to our university and the opening of the “Scientific Sessions” of the 15th International Scientific Conference on “*Energy and Climate Change*”.

The Conference is organized continuously by the Energy Policy and Development Centre (KEPA) of our University since 2008 and it is supervised by an international scientific committee which has the responsibility for the quality of the abstracts that are presented.

The Conference all those years functions under the aegis of the Black Sea Economic Cooperation Organization and of the United Nations Academic Impact.

As University authorities we are quite satisfied from the contribution of KEPA and more specifically from the continuous efforts of Prof. Dimitrios Mavrakis and his colleagues to develop and function the PROMITHEAS network and the BSEC - Green Energy Network with its multifold activities.

We are experiencing difficult times with the occurrence of the expanding global economic recession, the post Covid era and the ongoing negative repercussions of the security of energy supply.

I will not take your time analyzing the situation nor referring to our task to support our societies to find the optimum solutions, but I hope you agree that we are invited to propose optimum solutions to resolve all these problems.

Climate change occurs regardless of partial or local conflicts. Extreme weather phenomena occur with an increasing intensity. Satisfying the basics of the security of energy supply consists a sine qua non condition for the survival of our societies.

Finding efficient solutions for those challenges drive use to contradicting decisions that should be balanced and I believe that you can contribute consulting decision makers to optimum solutions.

As Vice Rector of this university, I would like to reassure our intention to increase and further expand our support to KEPA, based on its proved experience, in the spectrum of activities that coincides with the initiatives and efforts of those of the United Nations Academic Impact and of the policies of BSEC.

The established experience of KEPA and its dual role as the UNAI Hub for SDG7 and as the coordinator of the BSEC - Green Energy Network allows me to expect a further increase of cooperation, in the frame of existing relations with academic entities and institutions from the Black and Caspian Seas, the Central Asia, the Asia – Pacific and Africa and America.

This year the conference brings together high-level officials from regional and international organizations, ambassadors from Europe, BSEC-Members states, market players and most important scientists from 14 countries from Europe, Central Asia, Asia – Pacific, Africa and America with the double aim to contribute to a high-level scientific dialogue and to provide the ground for future cooperation.

In this frame I am looking forward to a fruitful conference and I cordially wish you success in all your activities.

UNAI Hub SDG 9 - Industry, Innovation and Infrastructure

Dr. Mami KATSUMI

*UEA (Education Administrator), Center for International Industry-Academia Collaboration,
member of Office for SDGs Promotion,
Nagaoka University of Technology, Japan*



Short CV

Dr. Mami KATSUMI was graduated from Department of Physics, Graduate School of Science, Chiba University (Ph.D. in Sci.). Her major was radiation biophysics. She has Teaching Certificate (Elementary, Science of Junior and High school). She has been engaged in development of modeling the biological response for heavy particle beam cancer treatment. After working as a fixed-term staff member at the National Institute of Radiological Sciences (Chiba), as a part-time lecturer at career college and high schools in Tokyo and Chiba Prefecture, and as a sales representative for a global logistics company (Malaysia), she joined Nagaoka University of Technology in 2014. Currently, she is in charge of undergraduate and master's lectures, including exercises in engineer capabilities as UEA. And she promotes international education and research collaboration and international industry-academia collaboration. She was specially appointed by the president as a specialist in planning and promoting the SDGs. As the UNAI SDG9 Hub University, she is responsible for the creation of teaching materials necessary for promoting the SDGs at the university, engineering education using these materials, supporting research activities aimed at achieving the SDGs, and publicizing the results. Furthermore, she is providing opportunities for learning SDGs to teachers and students in elementary, junior high, and high school and KOSEN.

**UNAI hub for
SDG9**

Nagaoka University of Technology
UEA/Education Administrator
Dr. Mami KATSUMI



Nagaoka Univ. of Tech.

Nagaoka University of Technology

NagaokaUT aims to establish itself as an indispensable member of global society, a university which

- ✓ creates **GIGAKU (Science of Technology)** with a proactive approach to societal change,
- ✓ produces **engineers with practical, creative capabilities and a spirit of service who will lead society into the future,**
- ✓ places emphasis on **graduate-level education.**

NagaokaUT's **V** stands for **Vitality**,
O for **Originality**, and
S for **Services to society.** |



長岡技術科学大学
Nagaoka University of Technology

Nagaoka Univ. of Tech.

Nagaoka University of Technology

Nagaoka
長岡



1.5h by  Shinkansen

Nagaoka Univ. of Tech.

Nagaoka University of Technology



Academic Agreement: | 8 institutions in 32 countries and regions

Nagaoka Univ. of Tech.

Nagaoka University of Technology

GIGAKU Tech Park Office: 12 offices in 9 countries
Academic Agreement: 18 institutions in 32 countries and regions

Nagaoka Univ. of Tech.

4

Nagaoka Univ. of Tech.

UNAI SDG Hub University

First term: 2018-2021

Nagaoka Univ. of Tech.

5

Nagaoka Univ. of Tech.

UNAI SDG Hub University

Second term: 2018-2021

Nagaoka Univ. of Tech.

6

Nagaoka Univ. of Tech.

UNAI SDG Hub University

Academic Impact

Nagaoka Univ. of Tech.

GIGAKU Education

What is GIGAKU?

技/GI/



A hand holding a tool

学/GAKU/

Book hold by hands



A child studying at desk

8

GIGAKU Education

What is GIGAKU?

✓ Speech delivered at the first Entrance ceremony by Dr. Masamitsu KAWAKAMI, the first President of NagaokaUT, and introduce about GIGAKU

✓ To produce high-quality products efficiently using science and engineering

Types of studies	理学 Science (narrowly defined)	工学 Engineering	技学 Science of Technology
Discipline	基本的分野 Basic Science	戦略的分野 Strategic Science	実践的分野 Practical Science

GIGAKU Education

Progress of International Cooperation and Industry-Academia-Government Cooperation



10

GIGAKU Education

Education System - Higher education institutions and high school / Academic year: April - March

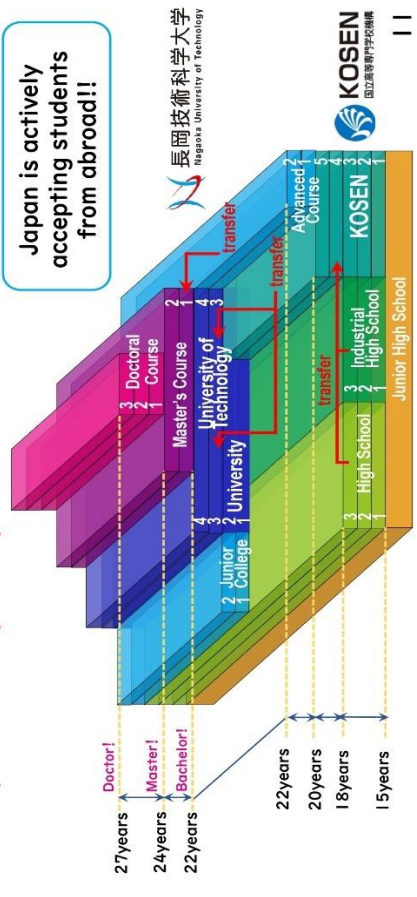

GIGAKU Education

KOSEN-NagaokaUT

- ✓ Long-term practical engineering education system

KOSEN :5years
NagaokaUT :2years(Bachelor)
+ 2years(Master)

- ✓ Collaborate with KOSEN and companies in Japan through GIGAKU Network

12

GIGAKU SDG Institute

GIGAKU SDG Institute's teaching programs

- ✓ **SDG Engineer Course** (Joint Bachelor-Master Program)
- ✓ **SDG Professional Course** (Master-Doctor program for working professionals)
- ✓ **GIGAKU Innovation Program** (5-year integrated Doctoral Program)

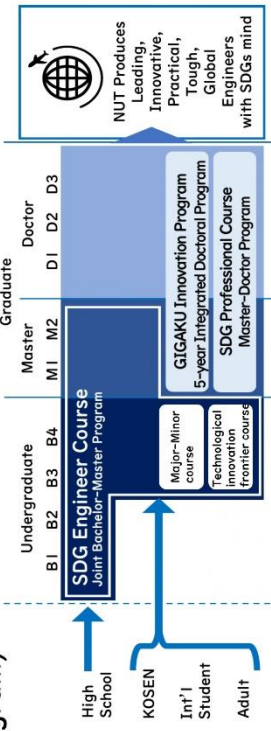

14

GIGAKU SDG Institute

NagaokaUT's Engineering Education Program was certified by UNESCO

- ✓ Establishment in Japan: 9th
- ✓ Program name [GIGAKU SDG Institute]
- ✓ Pillar of Engineering Program: **SDGs & Practical Engineering Education**

13

Nagaoka Univ. of Tech.

Type of Learning Opportunities to Students

- ✓ To develop student capabilities to transform their knowledges to solve real world problems which global societies are facing today, GIGAKU Institute offers **5 types of learning activities** to student;

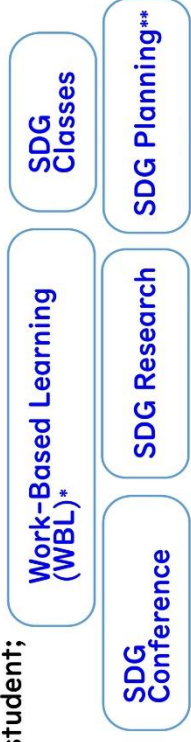

- ✓ Each program (SDG Engineer Course, SDG Professional Course, and GIGAKU Innovation Program) has a different combination of above learning activities
- *Optional: SDG Professional Course
**Optional: SDG Engineering Course

15















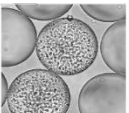
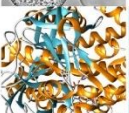
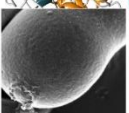
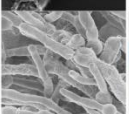

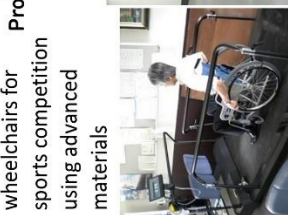

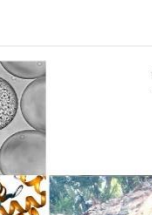



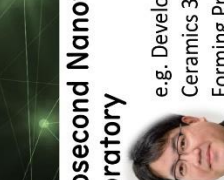

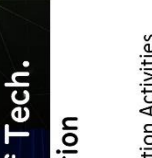

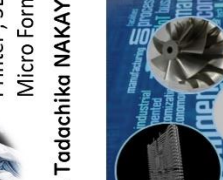
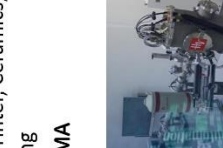

<p>Nagaoka Univ. of Tech.</p> <p>Sports Engineering and Physiology Biological Information Laboratory</p> <p>e.g. Development of wheelchairs for sports competition using advanced materials</p> 	<p>Nagaoka Univ. of Tech.</p> <p>Motion Control Laboratory</p> <p>e.g. Development of Low-cost inverters for room air conditioners</p>  <p>Compressor unit for an air conditioner mounted with new inverter base</p>  <p>Conventional inverter base</p>  <p>New inverter base</p>	<p>Nagaoka Univ. of Tech.</p> <p>HAKKO Science Laboratory</p> <p>e.g. Microorganisms fermentation</p>    	<p>Nagaoka Univ. of Tech.</p> <p>Power Electronics Laboratory</p> <p>e.g. Development of next-generation high-capacity ultra-rapid chargers for EV</p>  <p>Rapid charger for EV</p> 
<p>Nagaoka Univ. of Tech.</p> <p>Intelligent Information Laboratory</p> <p>e.g. Promotion Activities for education and research of Nocode</p> 	<p>Nagaoka Univ. of Tech.</p> <p>Aqua and Soil Environment Laboratory</p> <p>e.g. Development of a seawater purification system using microorganisms</p>  	<p>Nagaoka Univ. of Tech.</p> <p>Mathematical Design Laboratory</p> <p>e.g. Development of new computational scheme for topology optimization analysis</p>  <p>Load F</p> <p>What is the best material distribution so as to minimize the total strain energy?</p>  <p>Wow!! It looks like a truss bridge!</p> <p>Topology optimization</p>	<p>Nagaoka Univ. of Tech.</p> <p>Nanosecond Nanotechnology Laboratory</p> <p>e.g. Development of Ceramics 3D Design and Forming Process with 3D Printer, 3D Printer, Ceramics, Micro Forming</p>  
<p>Nagaoka Univ. of Tech.</p> <p>Power Electronics Laboratory</p> <p>e.g. Development of next-generation high-capacity ultra-rapid chargers for EV</p>  <p>Rapid charger for EV</p> 	<p>Nagaoka Univ. of Tech.</p> <p>Mathematical Design Laboratory</p> <p>e.g. Development of new computational scheme for topology optimization analysis</p>  <p>Load F</p> <p>What is the best material distribution so as to minimize the total strain energy?</p>  <p>Wow!! It looks like a truss bridge!</p> <p>Topology optimization</p>	<p>Nagaoka Univ. of Tech.</p> <p>Intelligent Information Laboratory</p> <p>e.g. Promotion Activities for education and research of Nocode</p> 	<p>Nagaoka Univ. of Tech.</p> <p>Power Electronics Laboratory</p> <p>e.g. Development of next-generation high-capacity ultra-rapid chargers for EV</p>  <p>Rapid charger for EV</p> 
<p>Nagaoka Univ. of Tech.</p> <p>Power Electronics Laboratory</p> <p>e.g. Development of next-generation high-capacity ultra-rapid chargers for EV</p>  <p>Rapid charger for EV</p> 	<p>Nagaoka Univ. of Tech.</p> <p>Mathematical Design Laboratory</p> <p>e.g. Development of new computational scheme for topology optimization analysis</p>  <p>Load F</p> <p>What is the best material distribution so as to minimize the total strain energy?</p>  <p>Wow!! It looks like a truss bridge!</p> <p>Topology optimization</p>	<p>Nagaoka Univ. of Tech.</p> <p>Intelligent Information Laboratory</p> <p>e.g. Promotion Activities for education and research of Nocode</p> 	<p>Nagaoka Univ. of Tech.</p> <p>Power Electronics Laboratory</p> <p>e.g. Development of next-generation high-capacity ultra-rapid chargers for EV</p>  <p>Rapid charger for EV</p> 
<p>Nagaoka Univ. of Tech.</p> <p>Power Electronics Laboratory</p> <p>e.g. Development of next-generation high-capacity ultra-rapid chargers for EV</p>  <p>Rapid charger for EV</p> 	<p>Nagaoka Univ. of Tech.</p> <p>Mathematical Design Laboratory</p> <p>e.g. Development of new computational scheme for topology optimization analysis</p>  <p>Load F</p> <p>What is the best material distribution so as to minimize the total strain energy?</p>  <p>Wow!! It looks like a truss bridge!</p> <p>Topology optimization</p>	<p>Nagaoka Univ. of Tech.</p> <p>Intelligent Information Laboratory</p> <p>e.g. Promotion Activities for education and research of Nocode</p> 	<p>Nagaoka Univ. of Tech.</p> <p>Power Electronics Laboratory</p> <p>e.g. Development of next-generation high-capacity ultra-rapid chargers for EV</p>  <p>Rapid charger for EV</p> 

Fig. 1.: The screens of the news application produced in the Nocode class. (a) Home, (b) Main text of news, (c) Submission form.

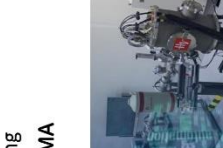
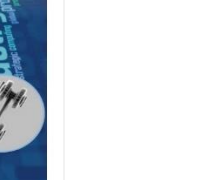
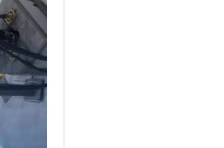
International Conference “STI-Gigaku”

2022 International Conference on Energy and Climate Change, 12-14 October 2022 (in situ and on line)

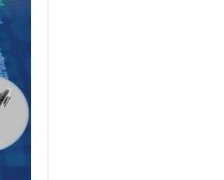
2021 International Conference “STI-Gigaku” was held

2020 International Conference “3rd STI-Gigaku” was held

2019 International Conference “2nd STI-Gigaku” was held

2018 International Conference “1st STI-Gigaku” was held

2017 International Conference “2nd STI-Gigaku 2017” was held

2016 Sustainable Development Goals (SDGs) was launched in 2016

2015 Millennium Development Goals (MDGs) was formulated in 2001

2014 “GIGAKU SDG Institute” certified by UNESCO as a UNESCO Chair Program

2013 “SAKURA” trip xSDGs Week was held

2012 Resona Group “SDGs Promotion Placement Bond”

2011 Appointed by the UNAI as the world’s only “Hub university for SDGs” (Industry, Innovation and Infrastructure)

2010 Revealed as “The Long Society 21 for SDGs” to promote corporate globalization support

2009 2nd term appointment of “Hub university for SDGs”

2008 Appoint ceremony of 1st Student SDGs Promoter

2007 Establishment of Office for SDGs Promotion

2006 International Conference 6th STI-Gigaku 2019 was held

International Conference “STI-Gigaku”

STI-Gigaku

The 7th STI-Gigaku
November 18 & 19

22

International Conference “STI-Gigaku”

STI-Gigaku

7th STI-Gigaku 2022

International Conference on Science of Technology Innovation

Date: Nov. 18(Fri) - 19(Sat) 2022

Venue: Aore Nagasaki, Nagasaki Univ. of Tech., Online

Contact: sti-gigaku@nitech.ac.jp

- ✓ For KOSEN and NagaokaUT student
- ✓ Organizes by NagaokaUT Student
- ✓ Declare related SDGs of their research
- ✓ Participation of companies (from 4th)
- ✓ Award by sponsored company
- ✓ Keynote speeches by international participants
- ✓ Giving opportunity to talk about research and SDGs

Nagaoka Univ. of Tech.

UNITWIN Networks

GIGAKU Institute

GIGAKU SDG Network

UNESCO

MU

UD

France

Spain/Basque Country

India

Vietnam

Japan

Mongolia

Mexico

UG

NUT

NIT

MUST

NMCT

HUST

IITM

NIT, Fukushima College

Company: Western Distal (Thai)

NUT and 9 institutes applied to UNITWIN → Start soon!!

23

Thank you for your attention

**Nagaoka University of Technology
UEA/Education Administrator
Dr. Mami KATSUMI**

UNAI Hub SDG 10 - Reduced Inequalities

Prof. Mwangi Peter WANDERI

Mount Kenya University, Kenya



Short CV

Prof. M. P. WANDERI, Associate Professor and Director, University – Industry Partnerships, Kenyatta University, Kenya, has over 22 years of teaching experience at the University in the areas of Sport Anthropology, Exercise Physiology, and Pedagogy of Physical Education and Sports; has supervised over 50 postgraduate candidates at various levels up to PhD and has published widely in these areas.

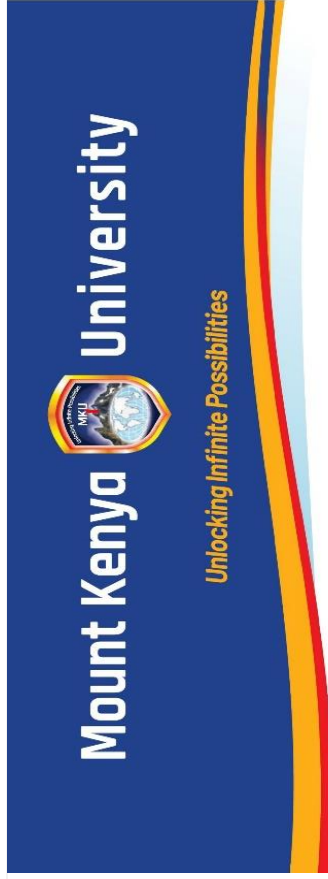

Mount Kenya University
Unlocking Infinite Possibilities

**PROMOTION OF GREEN ENERGY FOR REDUCED INEQUALITIES:
The Case of Mount Kenya University in Eastern Africa Region.
(The UNAI SDG 10 Hub on Reduced Inequalities)**

by **M. Peter Wanderi and Simon N. Gicharu**
An Online Presentation During the 9th Green Energy Investments Forum
- Athens, Greece, on 13th October 2022

ABOUT MOUNT KENYA UNIVERSITY (MKU)

The Entrepreneurial University which is a Chartered and ISO 9001:2015-Certified institution of higher learning with a conspicuous presence throughout the East African Region.

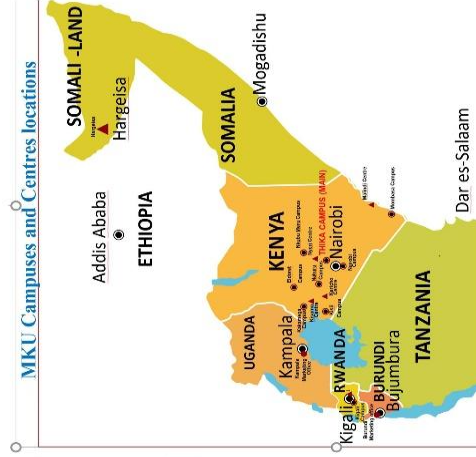

“The Entrepreneurial University in Eastern Africa”
Mount Kenya University

PROF. (DR) SIMON N. GICHARU, CBS
Founder of MKU was inducted into the World Entrepreneurs of the Year Hall of Fame in Monaco, France in 2014 and was Eastern Africa Entrepreneur of the Year in 2014.

Unlocking Infinite Possibilities

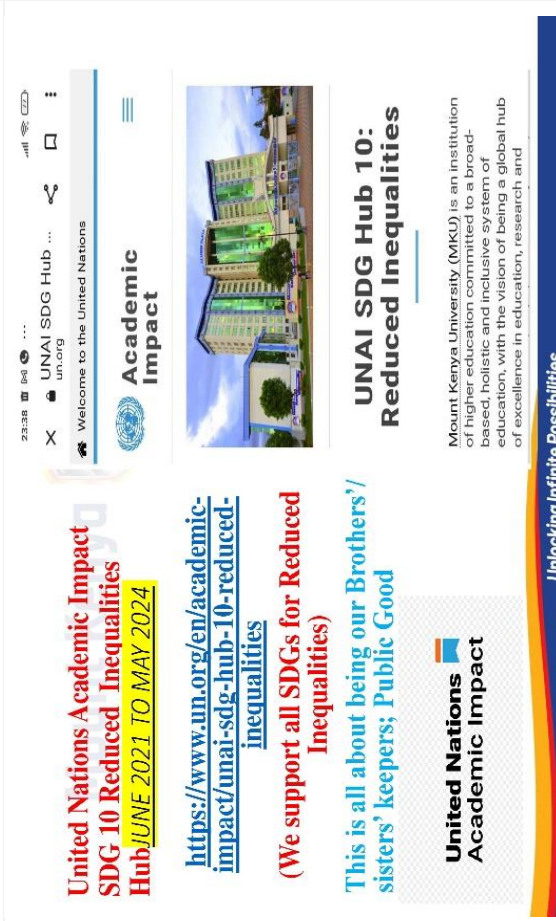

United Nations Academic Impact
SDG 10 Reduced Inequalities
Hub JUNE 2021 TO MAY 2024

<https://www.un.org/en/academic-impact/unai-sdg-hub-10-reduced-inequalities>
(We support all SDGs for Reduced Inequalities)

This is all about being our Brothers'/sisters' keepers; Public Good

United Nations Academic Impact

UNAI SDG Hub 10: Reduced Inequalities

Mount Kenya University (MKU) is an institution of higher education committed to a broad-based, holistic and inclusive system of education, with the vision of being a global hub of excellence in education, research and

Unlocking Infinite Possibilities

Our overall SDGs 2030 support at MKU UNAI SDG10 Hub on Reduced Inequalities (supporting all sectors to reduce inequalities) ACTIVITIES



1. University Scholarships support (“Education is the most powerful tool to change the world.” (Nelson Mandela, Former South Africa President.)
2. Support to the Persons Living With Disabilities both at the university and out of school (who are referred to within the MKU circles as Persons Enabled Differently)
3. Medical care interventions and human health support especially among the poor community members who would otherwise go without medical support. MKU has a dedicated college of Health Sciences for capacity development in health care
4. Entrepreneurial Promotion amongs recovering drugs and substances addicts.
5. Conferences, eg Peace conference in May 2022, and a Water Summit scheduled for early November 2022 and many other activities

Unlocking Infinite Possibilities

GREEN ENERGY PROMOTION FOR REDUCED INEQUALITIES

Three Masters students from Mount Kenya University won an international grant to distribute solar- powered lanterns to families in Kiandutu slums in Thika

Kiandutu, is largest informal settlement in Thika sub-County, Kiambu County and has a population of about 30,000 people. “Our initial target is 200 homesteads. But we aim to scale it up in due course,” Macharia, one of the grant-awardees said.

Unlocking Infinite Possibilities

GREEN ENERGY PROMOTION FOR REDUCED INEQUALITIES

1. My Office as the UNAI SDG 10 Hub on Reduced Inequalities is mandated by an annual Performance Contract and Guided by Strategic Plan 2021 - 2029 to Promote Green Energy Kenya

5.3 To promote sustainable Green Energy Enterprise by the Office of the Principal Corporate services and Overseer of the UNAI SDG 10 Hub on Reduced Inequalities							
5.3.1 Develop the Green Energy Enterprise	Develop the Green Energy Enterprise Policy	Approved Policy	Number	1	0	1	A Draft Policy has been developed
	Develop Green Energy Technology Park Proposal	Approved Proposal	Number	1	0	1	In process of finalizing the proposal
	Implement Green Energy in MKU	% in electricity reduction use at MKU & for Community support	%	2	0	5	Arrangements ongoing

Unlocking Infinite Possibilities

GREEN ENERGY PROMOTION FOR REDUCED INEQUALITIES

Rural Electrification & Renewable Energy Corporation in Kenya had its Chairman as Prof. Simon Gicharu for over 8 years (2014 - 2022); He is the Founder of MKU and Chair of the MKU Board of Directors;

Mt Kenya University boss Simon Gicharu reappointed chair of Rural Electrification Authority board

© Sunday, February 16, 2019 at 12:19 PM - by Mwangi Reberto

- The authority (REA) is charged with extending power connections to rural areas with schools being biggest beneficiaries
- Gicharu has served in the same capacity since 2014 after he was moved from Geothermal Development Company

Unlocking Infinite Possibilities

GREEN ENERGY PROMOTION FOR REDUCED INEQUALITIES

President Uhuru Kenyatta being welcomed by the Rural Electrification Authority (REA) Chairman, Prof. Simon Gicharu, (center) as he introduces the REA board members to president, during the inauguration of 50MW Solar Power plant in Garissa county.

The solar farm

sits on 85 hectares

(210 acres) and

consist of 200,200

solar panels, the

largest in East and

Central Africa.

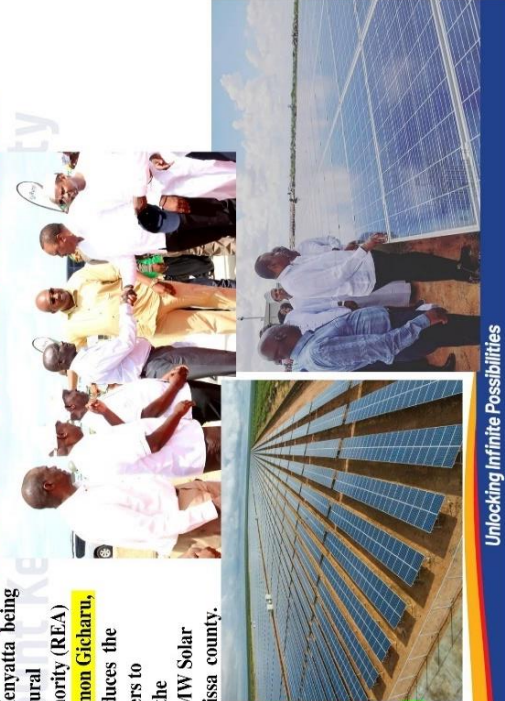

Unlocking Infinite Possibilities

GREEN ENERGY PROMOTION FOR REDUCED INEQUALITIES MKU SCHOOL OF ENGINEERING AND BUILT ENVIRONMENT OFFERS COURSES IN GREEN ENERGY

- Bachelor of Science Energy and Environmental Technology
- MSc. Renewable Energy and Environmental Engineering

Unlocking Infinite Possibilities

❖ THANK FOR YOUR ATTENTION

THE LND

Unlocking Infinite Possibilities

UNAI Hub SDG 13 – Climate Action

Ms. María Soledad CASASOLA

Universidad Nacional de Rosario, Argentine

(video)

Short CV

Ms. Maria Soledad CASASOLA is the Director of Science Communication at the National University of Rosario (Argentine).

***Through its channel UNICANAL,
Universidad Nacional de Rosario (UNR)
has made BAJO RÍO (Low river),
an audiovisual production.***

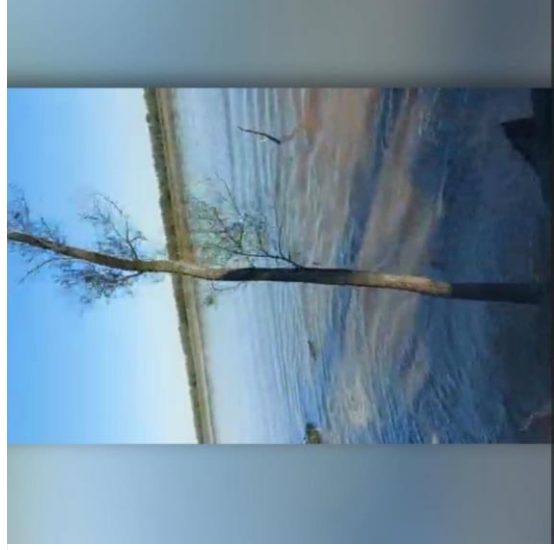

***It shows the consequences brought about
by the historical downspout of Paraná River:
changes in vegetation and animal behavior;
forced migration of some species;
alteration of fishes reproductive cycles;
strains on drinking water collection systems
for human consumption;
difficulties to navigate
and extreme vulnerability to human action.***

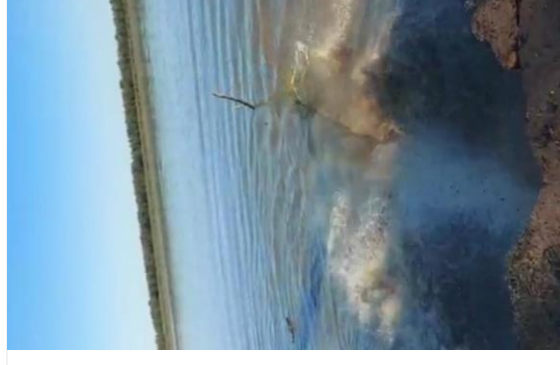

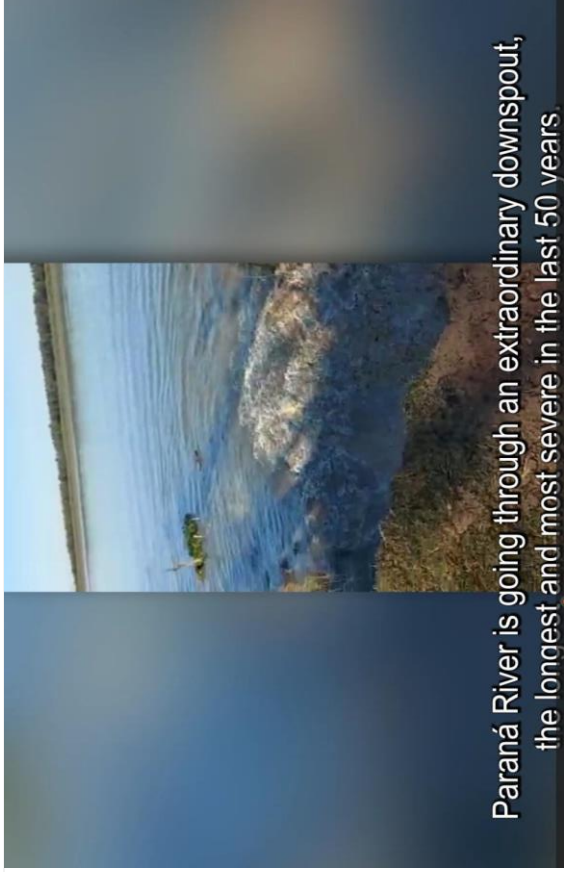

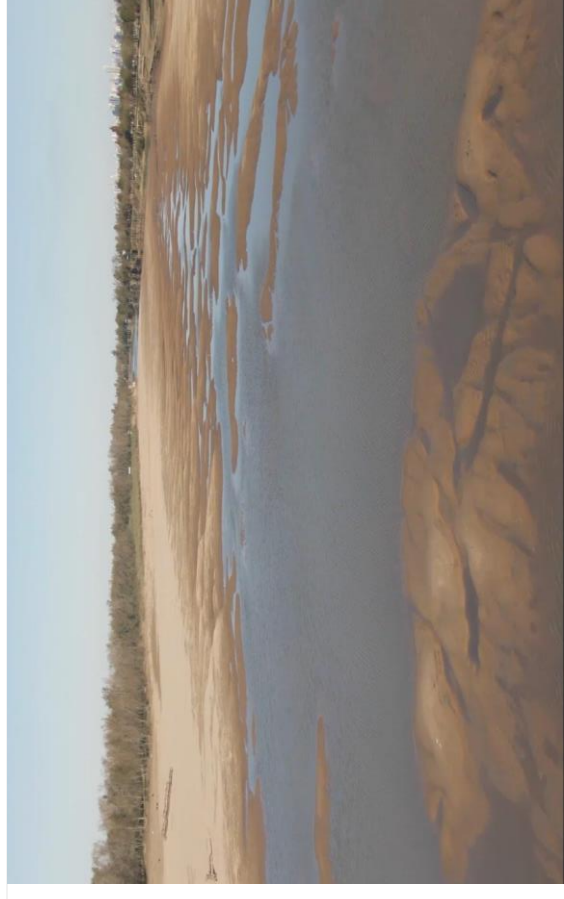
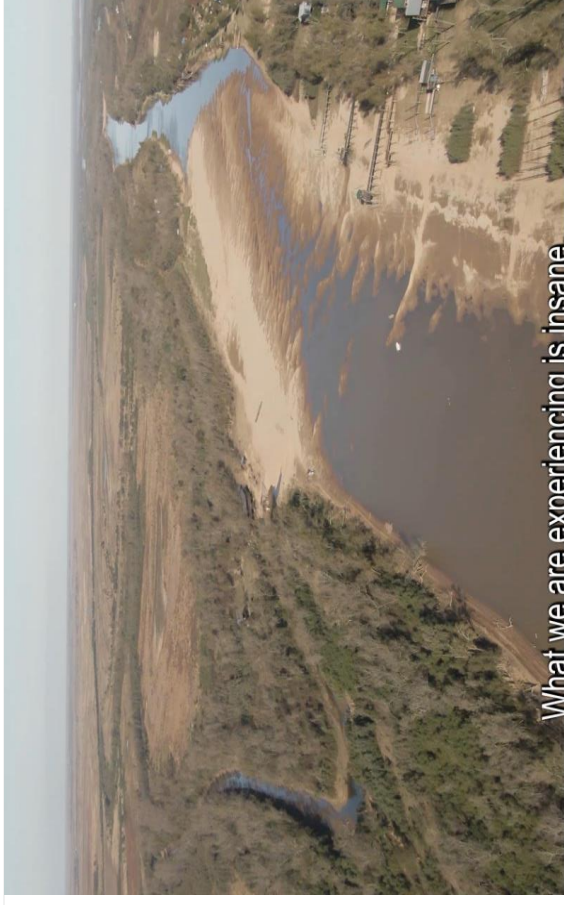

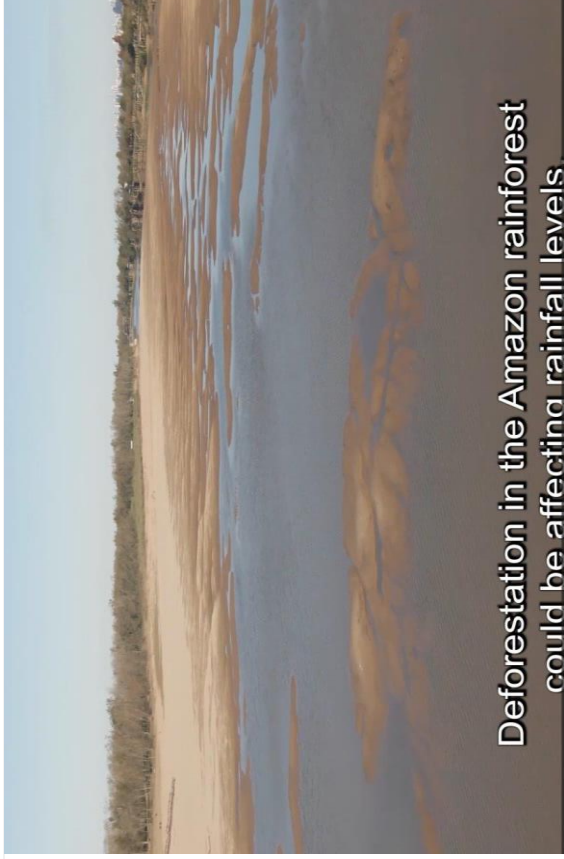



We produce 600 million liters of drinking water a day.
Eventually, we may have to adjust this water supply.



We produce 600 million liters of drinking water a day.
Eventually, we may have to adjust this water supply.



We produce 600 million liters of drinking water a day.
Eventually, we may have to adjust this water supply.

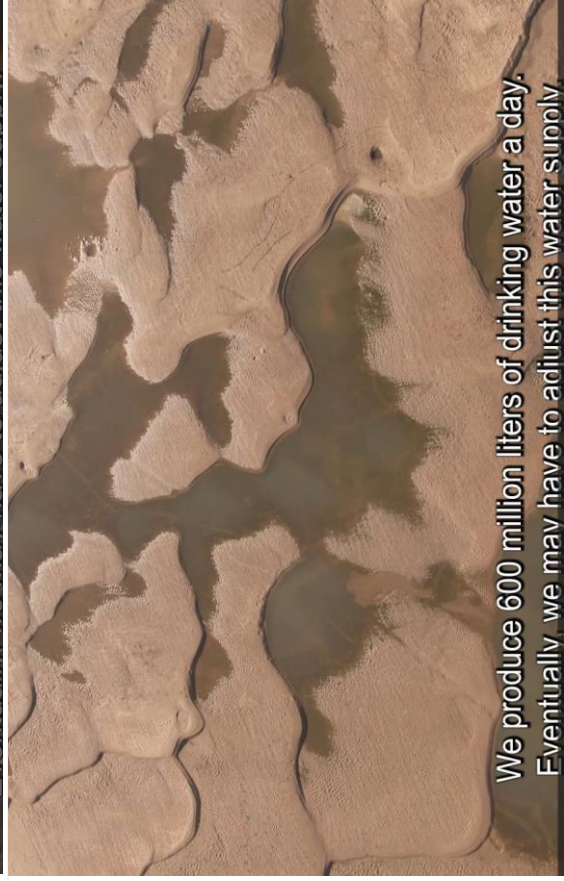

We produce 600 million liters of drinking water a day.
Eventually, we may have to adjust this water supply.



It was dramatic to see lagoons so dry and fishes die



It was dramatic to see lagoons so dry and fishes die



I had never seen the river like this before.



UNAI Hub SDG 16 – Peace, Justice and Strong Institutions

Mr. Mark CHARLTON

DMU Square Mile Manager

(video)

Hello, I'm Mark CHARLTON,

I'm the lead for the United Nations Academic Impact Hub for SDG16 "Peace, Justice and Strong Institutions" at De Monte University (DMU) in Leicester.

Firstly, thank you for giving me the opportunity to speak at the International Scientific Conference on "Energy and Climate Change", in this Scientific Session. I am sorry I can't be there to join you on this occasion.

For this event, I was asked to describe how our SDG Hub is promoting SDG16 and how these are connected with energy and climate change. As a political scientist and a theme director for Netzero Research here at DMU. This is something that I'm really keen to discuss. Firstly, I would say that our university is highly committed to SDG16 and all SDGs. We see the significance in all the goals being achieved in order to tackle the major global issues and bring prosperity to our planet. To this end we focus much of our teaching and research around SDG16 and its interlinkages with other areas and SDG16 is crucial to allow other pockets of sustainable development to happen.

So, I call it the great enabler, because without SDG16 succeeding, it's hard or much harder for anything else to get done. So for example it is hard to achieve "No poverty" in a corrupted society. It is impossible to achieve quality education without human rights, you cannot create industry, innovation and infrastructure without the rule of law. And you could apply this idea to all other the rest SDGs, which leads me specifically to "Clean and Affordable Energy, SDG7" and the "Climate Action, SDG13" in the context of SDG16. We've seen or certainly some of us are feeling the effects of Russia's war in Ukraine and this is probably the most stark example of how peace and justice is so essential to achieving the global goals. This crisis has shown a need on clean, affordable energy.

Right now, in the UK, we're having discussions on how we might have to reduce our energy usage because we're so dependent like so many other countries, on the global supply chain. So we already know this conflict is having a regressive effect on our hopes of phasing out fossil fuels and it is also having impacts on how we achieve other global goals. The role of SDG16 in this context is now one of the pursuits of lasting peace and the hope of a strong democracy in the region, as Western countries continue to work together to bring the war to an end as quickly as possible.

So that's an example of how global events can be used to teach the importance of our SDGs. But I just like to revert back to something that I'm working on that I mentioned earlier about around football. I just want to share these slides briefly, if I may. In August, the UN announced its "Football for the Goals campaign" and this is to create a global platform where the football community could engage with an advocate for the Sustainable Development Goals. So, it was really exciting development. At the same time DMU started a project to support this. Two amateur football teams, one in a small town called Pipes, in Cobos and the other here in Leicester called Leicester Nirvana. Both of them have a vision of achieving net zero status as quickly as possible. And this is a good example that I want to share with you very briefly about how SDG16, SDG7 and SDG13 can work together in an academic sense through teaching and research and through giving voice to communities who want to be the change.

So, Pipes in Germany is a forward-thinking football team that is keen to become a net zero entity, but lives in the gaze of a coal fired power station, which you'll see in the background of this picture.

It faces its own culture and challenges of tradition, by wanting to become net zero in an area where coal mining and also the use of coal is a huge driver of the local economy.

Leicester Nirvana is slightly different in that it is a football team with 1000 black ethnic minority players, boys and girls who live in one of the highest areas of deprivation in the city. So, it is a very exciting project for me to take part in and through the lens of SDG16. Through collective decision making and the promotion of social justice we are giving children and their families a voice in the future they want and enabling them to work with our scientists here at DMU who are helping them to harness solar power and heat pumps.

Engaging with students who are acting as mentors towards activism and advocacy of climate action in their communities. This is a new project, it is moving forward at quite a pace. I wanted to share this as an example of how we want to achieve climate action SDG13, through developing new clean energy innovations, in SDG7. We really need to take everyone on that journey and leave no one behind and that's what our project aims to do.

So we believe our net zero project is quite innovative and we're very proud of it at the University. And with that I would like to thank you for your time and to just mention briefly that actually, if you like football or if you like climate action, I'm very happy for people to engage in this project. Many people are very passionate about sports and the ability to play sport, so please get in touch if you want to find out more.

This is a brief talk and I hope I haven't run over time, but I just wanted to demonstrate to you that SDG7, SDG13 and SDG16 need to work in tandem in order to make global progress on climate change.

So thank you very much for listening, have a wonderful conference and again I hope my talk wasn't too long.

Thank you!

Short CV

Mark CHARLTON is the DMU Square Mile Manager/PhD Student at the Faculty of Business and Law of the Leicester Castle Business School. Mark's interests are in community engagement, public engagement through research, universities as a public good, policies on tackling social exclusion through education and social mobility. He is currently manager of the award-winning DMU Square Mile programme that seeks to connect the university with the community and demonstrate the university as a public good. Mark's research examines policies that encourage public good in Higher Education and investigates university strategies for tackling social exclusion in local communities.

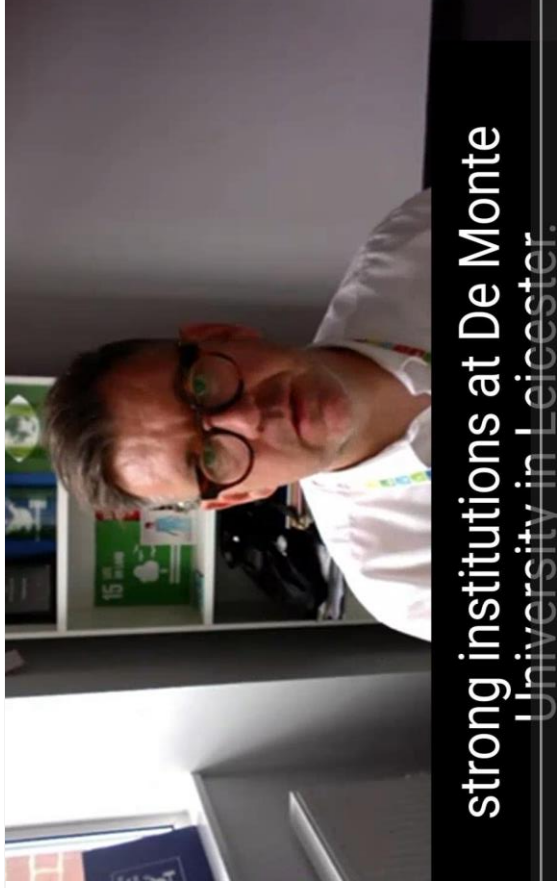
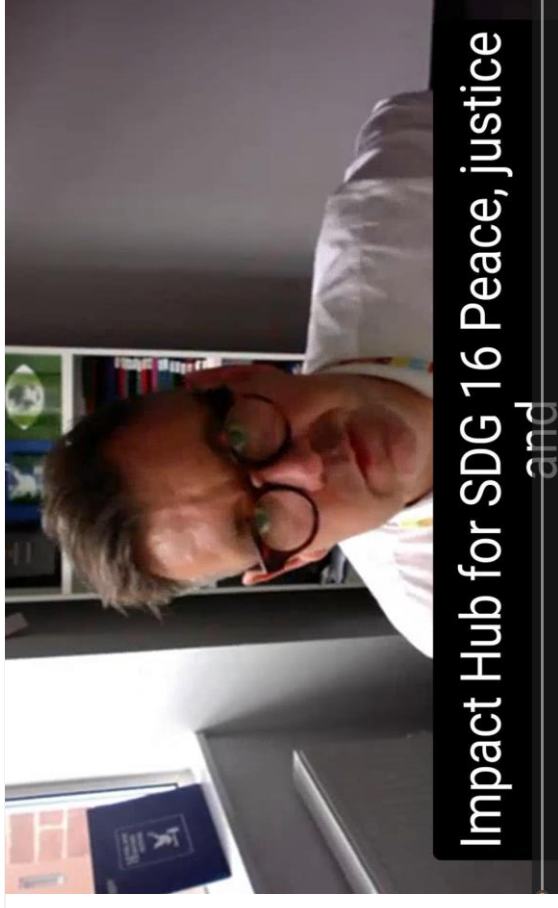
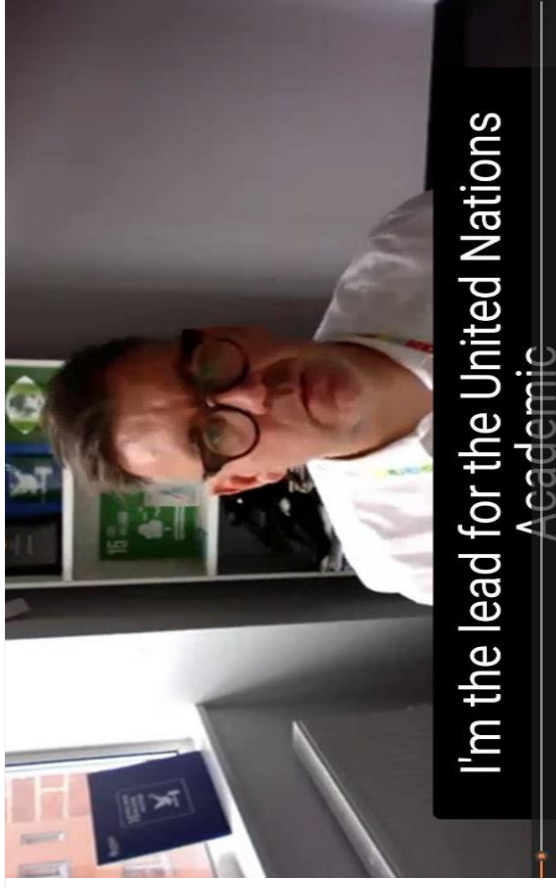
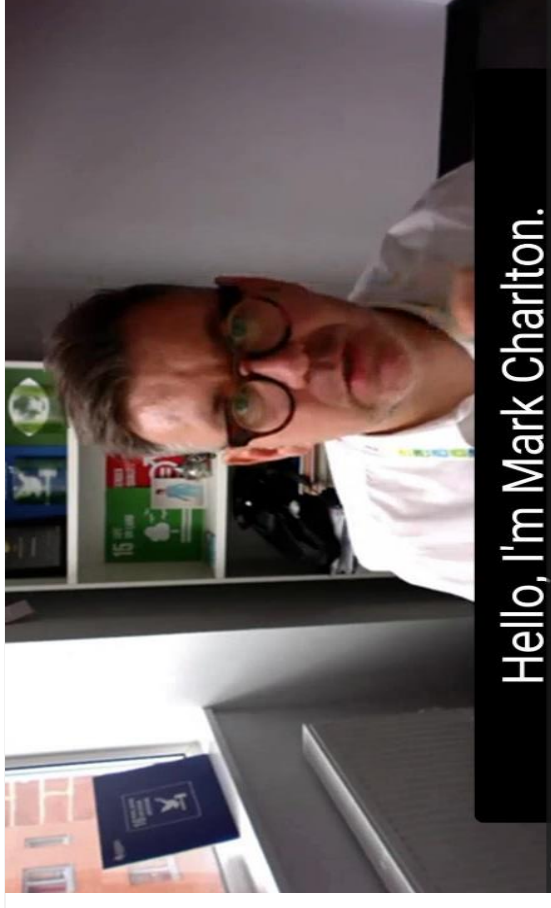



NET ZERO FOOTBALL



Research

DE MONTFORT UNIVERSITY
LEICESTER



One-quarter of English football grounds will be at risk from flooding every season within the next three decades

Research

DE MONTFORT UNIVERSITY
LEICESTER



Research

DE MONTFORT UNIVERSITY
LEICESTER



Research

DE MONTFORT UNIVERSITY
LEICESTER



Research
DE MONTFORT UNIVERSITY
LEICESTER

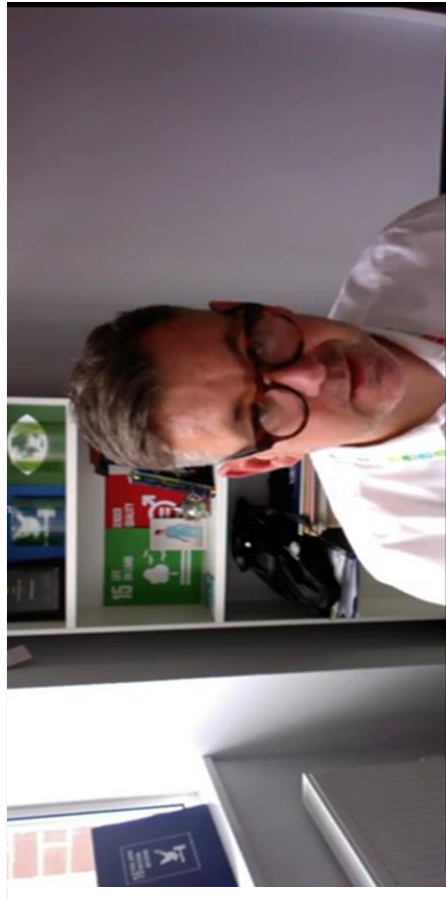

Have a wonderful conference and
again, I



hope my talk wasn't too long. Thank
you.

Opportunity for the development of renewable energy in Azerbaijan

Prof. Rauf ALIYAROV

Director of Geotechnological Problems of Oil, Gas and Chemistry – Azerbaijan

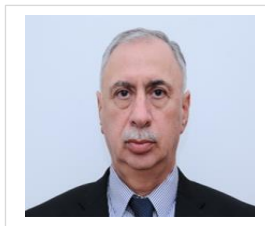

Dear colleagues!

I am very grateful to the organizers of the conference for the opportunity to participate in it, given that the conference is devoted to such an important issue, both for the European Community and for all mankind, related to the issues of climate change, which differ with frightening intensity, as well as renewable energy sources supplied to the population and industry.

These two problems are closely related and the widespread use of renewable energy sources will to some extent reduce the risks to humanity associated with climate change.

Today, for the European Community, energy security is an acute problem in the light of events taking place on the European continent.

The war in Ukraine and the aggressive policy of Russia aggravated the situation with the supply of European countries with hydrocarbon energy sources and the transition to alternative energy sources is an urgent need. Azerbaijan, as a state rich in hydrocarbon raw materials, is clearly aware that the future in the development of the energy sector is connected with the development of energy based on renewable energy sources. For this, a legislative framework has been prepared for the development of this energy sector. The relevant laws were adopted by the Parliament of the Republic.

The program to restore the development of Karabakh is based on the introduction of renewable energy sources in all economic spheres of this region and not only this region, but also in other economic zones of the Republic.

Therefore, research in this area is very important to us.

The Institute of Geotechnological Problems of Oil, Gas and Chemistry has long been aimed at solving problems related to the production of oil, gas and hydrocarbon processing technology.

Currently, the Institute, along with traditional scientific areas, is developing a direction related to alternative energy and the main emphasis is on hydrogen energy in terms of improving the technology for producing hydrogen both from hydrocarbon raw materials and from water, storing and transporting hydrogen.

Why do we emphasize hydrogen energy in our research, since hydrogen as a source has unlimited resources and high energy density, zero environmental impact.

For Azerbaijan, the most relevant technologies are the production of hydrogen from hydrocarbon gases and honey electrolysis.

The institute is conducting research on the development of catalysts to increase the efficiency of the methane steam convection process. Studies are underway to study the possibilities of carbon cellular structures for storing and transporting hydrogen, as well as in the direction of finding new materials for cathodes in order to increase the economic efficiency of the process of electrolysis of water, etc.

The specialists of our institute realize that these tasks are quite capacious and their successful implementation largely depends on collaboration with university scientists of the participants of today's conference and we are open to cooperation with those interested in conducting joint research.

Thank you for your attention.

Short CV

He is the Director of the "Geotechnological Problems of Oil, Gas and Chemistry" - Azerbaijan State Oil and Industrial University since 2021. For the period 2015- 2021 he was the Vice-rector on the scientific and technical works of the Azerbaijan State Oil and Industrial University. For the period 2003 – 2015 he was the Executive Director of the State Oil Company of the Republic of Azerbaijan (Shah Deniz) Limited Company, SOCAR.

Opportunity for the development of renewable energy in Azerbaijan

Director of the Institute, Doctor of Science Rauf Aliyarov

The solution to the problem of global warming is seen in the transition from the use of fossil fuels (coal, oil, gas), which currently constitute the main source of energy, to renewable energy sources such as wind, solar, hydropower and hydrogen energy.

Introduction

- ❖ Recent studies have shown that the increase in temperature and climate change on the planet depends on amount of greenhouse gases emitted into atmosphere and this is an important problem for mankind.
- ❖ According to expert estimates, by 2030 the air temperature may increase by 1-2°C.
- ❖ According to research by the Institute of Geography of the National Academy of Sciences of Azerbaijan, the temperature is also predicted to rise to 1.5 °C by 2030 on the territory of the Republic.
- ❖ Global warming will significantly worsen the conditions and quality of human life.
- ❖ The solution to the problem of global warming is seen in the transition from the use of fossil fuels (coal, oil, gas), which currently constitute the main source of energy, to renewable energy sources such as wind, solar, hydropower and hydrogen energy.

Global temperature change

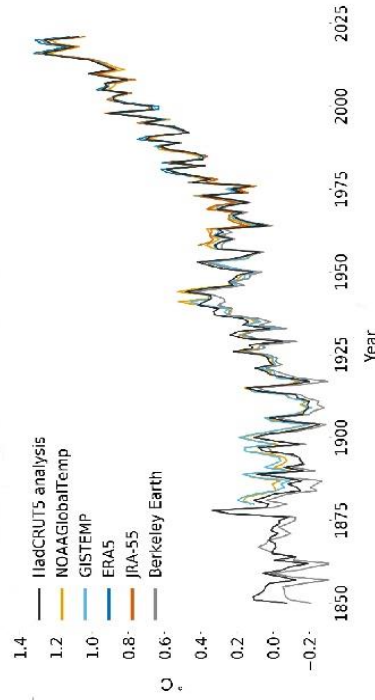

International Treaties on Mitigation of Climate Change

- ❖ In Paris, on December 12, 2015, an agreement was signed to curb global temperature growth below 2 ° C by reducing greenhouse gas emissions.
- ❖ These goals are planned to be achieved by switching electricity production to renewable sources, modernizing industrial and agricultural production.
- ❖ To reduce greenhouse emissions by 55% by 2030 (compared to 1990) and achieve carbon neutrality by 2050 by European countries, the CBAM mechanism - Carbon Border Adjustment Mechanism, i.e. the introduction of taxes on products whose production causes greenhouse gas emissions.

<p>International Agreements of Azerbaijan</p> <ul style="list-style-type: none"> ❖ Azerbaijan ratified the Energy Charter Treaty and Protocol on Energy Efficiency and Environmental Aspects on 2 December 1997 ❖ The purpose of the Energy Charter is to protect and encourage investment in energy, expand trade in energy materials, equipment (based on WTO rules), freedom of energy transit through pipelines and networks, and reduce the adverse environmental impact of the energy cycle by improving energy efficiency. ❖ Since 2009, Azerbaijan has become a member of the International Renewable Energy Agency (IRENA). ❖ Its activities are aimed at improving the political conditions for the promotion of renewable energy sources by advising industrialized and developing countries to assist in increasing the use of renewable energy sources (RES). 	<p>Legislative Framework of Azerbaijan for the Introduction of Alternative Energy</p> <ul style="list-style-type: none"> ❖ On November 20, 1996 on the initiative of the President of the Republic of Azerbaijan Heydar Aliyev Law No. 222 "On the Use of Energy Resources" was adopted. ❖ The law was developed in connection with the need to introduce energy-saving technologies and develop energy on the basis of renewable energy sources in Azerbaijan. ❖ It is important to note article 32 "Mandatory education in the field of rational use of energy resources" ❖ Energy training and training programs should provide a framework for the rational use of energy resources, including renewable and other energy sources.
<p>Legislative Framework of Azerbaijan for the Introduction of Alternative Energy</p> <ul style="list-style-type: none"> ❖ Also article 33 "Financing programs to improve educational and professional knowledge" ❖ Improving the training of employees responsible for the energy supply of enterprises, institutions and organizations, the development and implementation of training programs, seminars and conferences and other activities are financed by the fund for rational energy consumption ❖ This law once again testifies to the vision of Heydar Aliyev as a statesman and his role in the development of Azerbaijan 	<p>Legislative Framework of Azerbaijan for the Introduction of Alternative Energy</p> <ul style="list-style-type: none"> ❖ On May 31, 2021, Law No. 339-VI/Q "On the Use of Renewable Energy Sources in Electricity Production" was adopted ❖ The law defines the legal, economic and organizational basis for the use of energy sources in the production of electricity, as well as mechanisms for promoting the production of electricity from renewable sources. ❖ On June 6, 2009, the "State Agency for Alternative and Renewable Energy Sources" was established. ❖ The Agency's tasks are to formulate a policy to increase the volume of electricity generation from renewable energy sources and effectively manage energy resources.

International Agreements on the Development of Electricity from Renewable Energy Sources in Azerbaijan

- ❖ The Ministry of Energy of Azerbaijan and ACWA Power (Saudi Arabia) (13 January 2022), as well as Masdar (UAE) (6 April 2021) signed an agreement on the development of electricity production from renewable sources in Azerbaijan.
- ❖ On December 6 2021, the Ministry of Education and BP Azerbaijan signed a protocol on the creation of an educational program on renewable energy
- ❖ According to the protocol, universities of Azerbaijan in partnership with universities of Great Britain will develop a new master's program in renewable energy technologies.

RENEWABLE ENERGY POTENTIAL IN AZERBAIJAN

The potential of Azerbaijani renewable energy sources is estimated at 26,940 MBT, including 3,000 MBT for wind energy, 23040 MBT for solar energy, 380 MBT for bioenergy potential, and 590 MBT for the potential of mountain rivers.

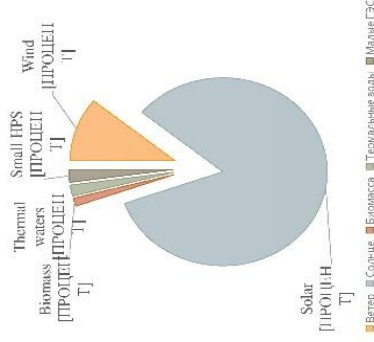

Potential of renewable energy in Azerbaijan

- ❖ It is also necessary to note the potential of wave energy, especially relevant for Azerbaijan given the length of the coastline of the Caspian Sea, constant sea currents.
- ❖ The territory of the Karabakh economic zone has significant potential in the development of renewable energy sources
- ❖ Solar
- ❖ Wind
- ❖ Hydropower (potential of mountain rivers)
- ❖ Thermal - western part of Karabakh (Kjalbajar region)

Hydrogen power engineering

- ❖ Hydrogen, as an energy source, is the most environmentally friendly and efficient in terms of generating electricity.
- ❖ Heat of hydrogen combustion is 1.175 joule/kg
- ❖ This is three times higher than oil and four times higher than gas and coal.
- ❖ The advantage of the development of hydrogen energy:
- ❖ Its high potential (the highest energy density is 33 kWh/kg)
- ❖ Availability of almost unlimited resources
- ❖ Consistency in time
- ❖ Zero environmental impact

<h3>Hydrogen power engineering</h3> <ul style="list-style-type: none"> ❖ In 2018, hydrogen consumption amounted to 74 million tons, by 2030 it is expected to increase hydrogen consumption to 100-114 million tons, and by 2050 - 370 million tons ❖ By 2050, the European Union plans to create a climate-neutral economy of energy production and consumption ❖ A significant drawback of hydrogen energy is the high cost of hydrogen generation, which reaches 2.5-6.8 dollars per 1 kg of fuel according to various sources. ❖ By 2030, the cost of hydrogen production is projected to fall to \$1 per kg, making it absolutely competitive compared to other types of electricity ❖ By 2050, the cost of hydrogen generation will be 0.8 dollars per kg 	<h3>Hydrogen Power Technology</h3> 
<h3>Hydrogen Power Technology</h3> <p>Production:</p> <ul style="list-style-type: none"> ■ From fossil raw materials (coal) ■ From natural gas (methane) ■ Water electrolysis using power sources (renewable, nuclear and hydroelectric power plants) <p>Transportation:</p> <ul style="list-style-type: none"> ■ network of special pipelines ■ in special tanks under high pressure ■ according to the existing gas pipeline system, subject to special preparation of a gas mixture (hydrogen + methane) 	<h3>Hydrogen Power Technology</h3> <p>Storage:</p> <ul style="list-style-type: none"> ■ In liquefied and adsorbed state; ■ In hydrogen accumulators: ■ titanium-based composite materials, ■ based on cluster carbon structures. <p>Application:</p> <ul style="list-style-type: none"> ■ Power generation at power plants (industrial, domestic) ■ Fuel Cell Electrical Installations ■ Road, rail, aviation

Introduction of hydrogen energy technology in Azerbaijan

For the introduction of hydrogen energy in Azerbaijan, two main ways can be identified:

1. Independent development of hydrogen energy technology
2. The introduction of technologies developed by foreign companies through the acquisition of technology licenses, the creation of consortia with the involvement of various companies or some other form of cooperation

Introduction of hydrogen energy technology in Azerbaijan

Advantages of self-development:

- Azerbaijan creates its own research and production base
- Training of scientific and technical personnel in the relevant areas
- Creation of modern multidisciplinary production

Disadvantages of self-development:

- To realize the problem of introducing hydrogen technology, significant own funds will be required
- The process will take a considerable time to implement
- There are risks of constant technological lag

Introduction of hydrogen energy technology in Azerbaijan

Advantages of collaboration with leading foreign companies:

- Solving the tasks in a shorter time frame
- Relatively lower costs of own funds

Disadvantages of collaboration with leading foreign companies:

- Dependence on foreign companies,
- Political and possible financial risks when borrowing from international financial institutions
- Partner Company Selection and Project Economic Model.

Directions of scientific research in the Institute on hydrogen energy

❖ **Hydrogen production**

- Raw materials for hydrogen production

For Azerbaijan, the most acceptable is the production of hydrogen from natural gas and the method of electrolysis of water.

It is advisable to use energy of renewable sources (solar, wind, thermal) and energy of hydroelectric stations as sources of electricity at low levels of its consumption

Hybrid energy sources, i.e. a combination of renewable and traditional energy sources.

Directions of scientific research at the Institute

- *Research areas*
- *Catalyst development to improve the efficiency of the methane steam convection process,*
- *Development of carbide-nitride catalysts in order to increase the efficiency of the electrolysis process.*
- *A study in the field of "cold" steam convection, i.e. a decrease in the temperature of the process. The existing technologies require a temperature of 700-1000 ° C.*
- *Analysis of electricity consumption, determination of time intervals for the use of energy generated by hydroelectric power plants, thermal power plants, the use of excess thermal energy for the production of hydrogen from methane, etc.*
- *Carbon capture technologies and its further application.*

Directions of scientific research at the Institute

❖ Hydrogen transportation

- ❖ Study and improvement of the technology of hydrogen transportation together with natural gas through the network of gas pipelines (main and local).

The technology of construction of pipelines for the transfer of hydrogen - "hydrogen pipelines."

❖ Storage

- The safest way is to store hydrogen in the adsorbed state. Based on this, the task arises to develop effective hydrogen accumulators, which make it possible to carry out the hydrogen storage and extraction process with the least losses.

Thanks for attention

Vertical Green Structures Impact on Microclimate: A case study in Milan

Ozge OGUT^{1,2*}, PhD Candidate,
Julia Nerantzia TZORTZI¹, Associate Prof.,
Chiara BERTOLIN², Full Prof.

¹Politecnico di Milano

²Norwegian University of Science and Technology

* *Contact details of corresponding author*

Tel: +39 3471002918

e-mail: ozge.ogut@polimi.it

Address: Building 5, piazza Leonardo Da Vinci, 42, 20133 Milan.

Abstract

Climate change, pandemic, and pollution are just some of challenges that have to be faced in urban areas. Especially more attention is needed due to the fast urbanism activities since it may accelerate the impacts of these problems. The issues urban areas are facing include environmental, economic, and social interactions, which make sustainability an obligation for reducing impact, and Nature-based Solution a key for successful mitigation accomplishment. Vertical Green Structures, as a type of green infrastructure embedded in built environments, are mostly developed in the last few decades. These structures represent effective solutions to respond to the sustainability requirements, here including air pollution decrease and energy efficiency enhancement of the building envelope. In fact, amongst environmental aspect, the vertical greenery serves as a thermal insulation layer. The present contribution reports the case study of a vertical green structure located in Milan, Italy where its potentiality of temperature reduction is investigated at microclimate scale by including concentration of particulate matters - PM 2.5 and PM 10 (μm), as well as temperature ($^{\circ}\text{C}$) and relative humidity (%). The methodology implemented to collect the data is based on a monitoring campaign measuring particulate matters, temperature, and relative humidity. The campaign aims to analyse the monthly and weekly variability of these parameters in proximity and few meters far away from the vertical green structure. The understanding of the microclimate modification caused by the vegetative layer during a whole calendar year will underline what are the factors that most influence the microclimate and air quality changes during the life stage of a vertical green structure if is it the design and material components, the operation of the vertical greenery, or its maintenance need.

Keywords: vertical green structure, microclimate, sustainability, air quality, energy efficiency.

References

- Perini K. & Roccotiello E., 2018. Vertical greening systems for pollutants reduction. In G. Perez & K. Perini (Eds.), *Nature based strategies for urban and building sustainability* (pp. 131–140). Amsterdam: Elsevier. <https://doi.org/10.1016/b978-0-12-812150-4.00012-4>.
- Srbinovska M., Andova V., Mateska, A. K. & Krstevska M. C., 2020. The effect of small green walls on reduction of particulate matter concentration in open areas. *Journal of Cleaner Production*, 123306. doi:10.1016/j.jclepro.2020.123306.
- Pérez G., Rincón L., Vila A., González J. M., & Cabeza L. F., 2011. Behaviour of green facades in Mediterranean Continental climate. *Energy Conversion and Management*, 52(4), 1861–1867. doi:10.1016/j.enconman.2010.11.008.
- Alexandri E., Jones P., 2008. Temperature decreases in an urban canyon due to green walls and green roofs in diverse climates, *Building and Environment* 43(4), 480 – 493.
- Eumorfopoulou E. A., Kontoleon K. J., 2009. Experimental approach to the contribution of plant-covered walls to the thermal behaviour of building envelopes, *Building and Environment* 44(5), 1024 – 1038.

**European Cities
addressing climate
change and
building urban
resilience
through Project
Harmonia**

Prof. Julia Nerantzia TZORTZI,
Associate Professor, PhD
Department of Architecture, Built
environment and Construction
engineering : Politecnico di Milano

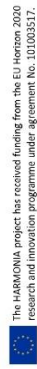

The HARMONIA project has received funding from the EU Horizon 2020 research and innovation programme under agreement No. 1010035317.

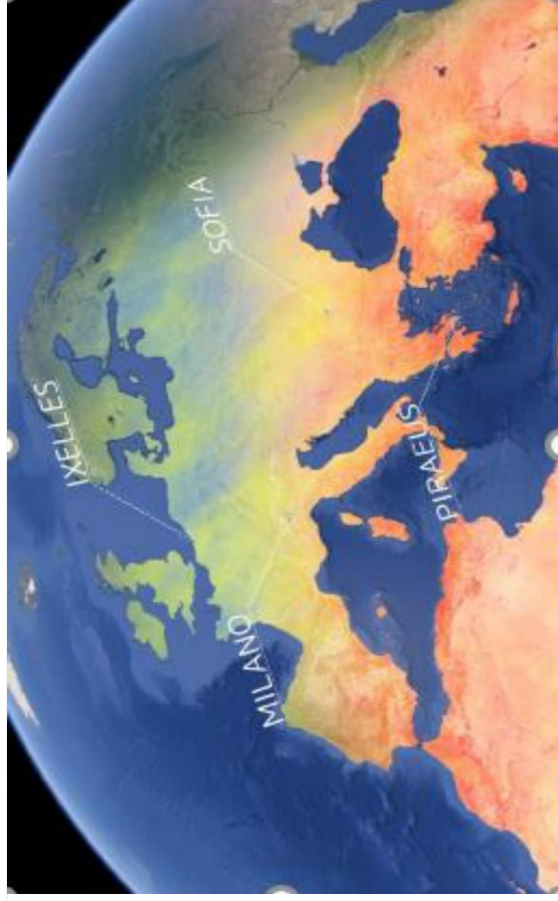

PARTNERS

22 PARTNERS

- 4 Academies
- 9 Companies
- 4 Research institutes
- 1 NGO
- 4 Municipalities

4 PILOT CITIES

- Milan (Italy)
- Sofia (Bulgaria)
- Piraeus (Greece)
- Ixelles (Belgium)



HARMONIA

Development of a Support System for Improved Resilience and Sustainable Urban areas to cope with Climate Change and Extreme Events based on GEOS and Advanced Modelling Tools

LC-CLA-19-2020: Integrated GEOS climate applications to support adaptation and mitigation measures of the Paris Agreement

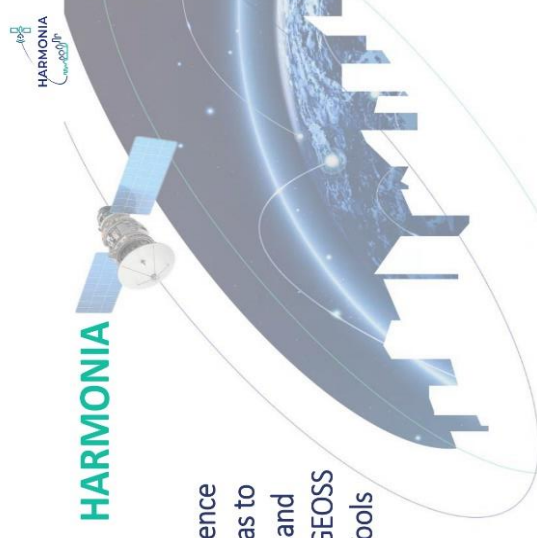

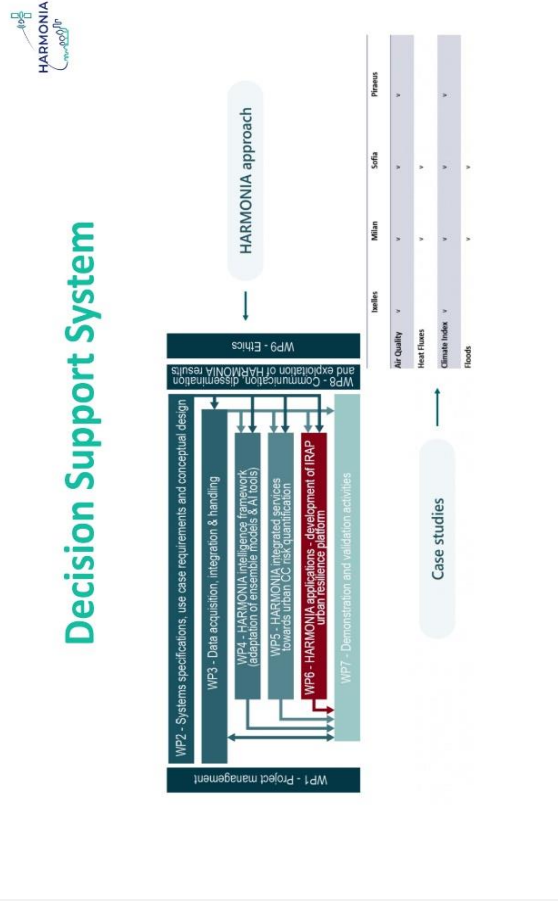
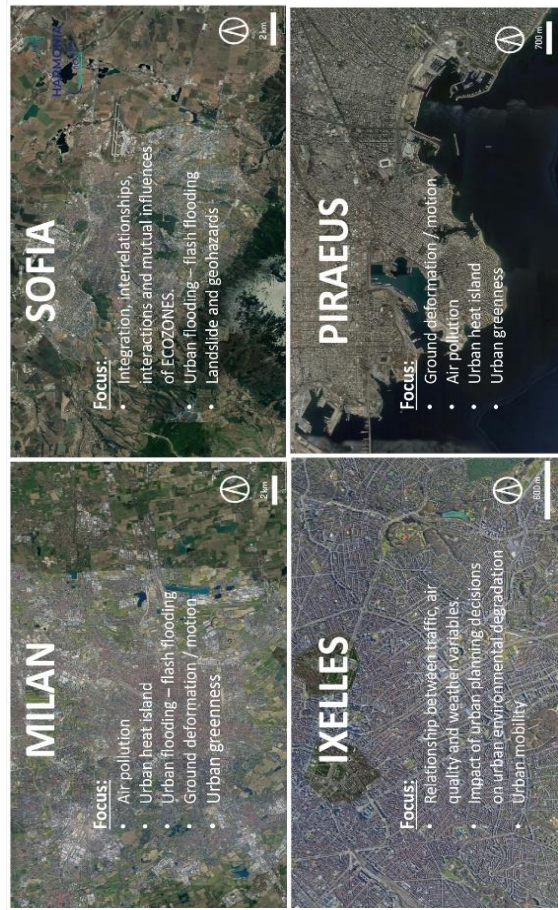
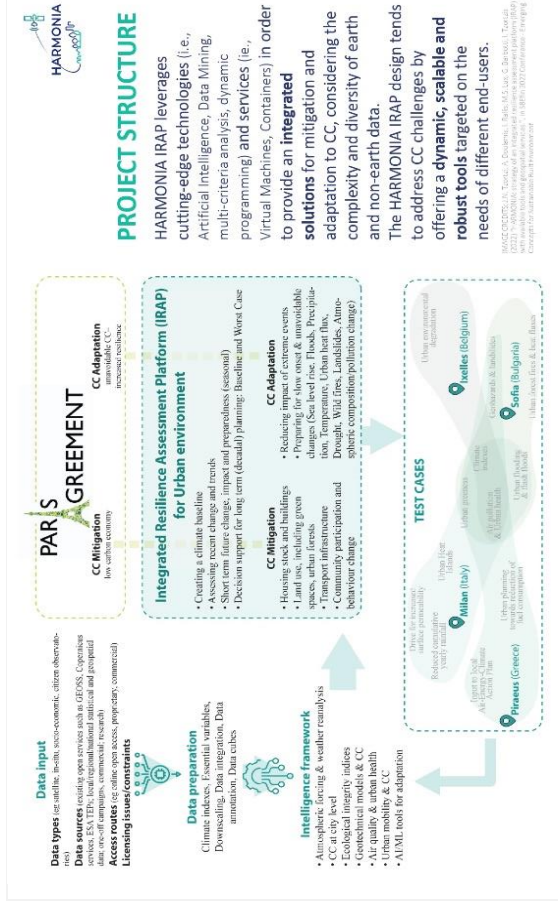

END-USERS

Municipalities, local administrators, urban planners and decision-makers

NEEDS: to receive support for better informed decision processes

SERVICE PROVIDED: Decision Support System (DSS) that will provide reliable feedback regarding any spatio-temporal changes and the impact of CC on the environment through a fully interactive Graphical User Interface (GUI)

Researchers, academia and industries

NEEDS: to get raw data from the platform and use it as a tool for training and evaluating new ML models

SERVICE PROVIDED: use of the platform for research and training purposes

Citizens and non-expert users

NEEDS: to be informed on Climate Change hazards; to gain awareness on potential risks

SERVICE PROVIDED: basic visualization of information and data + service of early-warnings and recommendations about potential risks such as heat peaks or extreme rainfalls

SMART, CLIMATE RESILIENT CITIES

SMART, CLIMATE RESILIENT CITIES



Urban surface Land cover

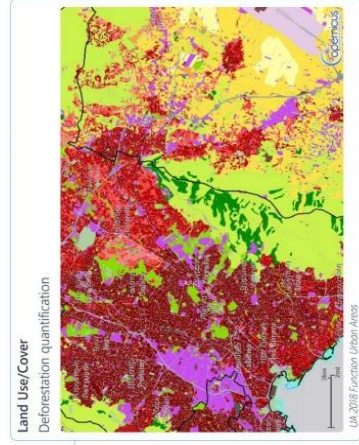

Urban surface Indices

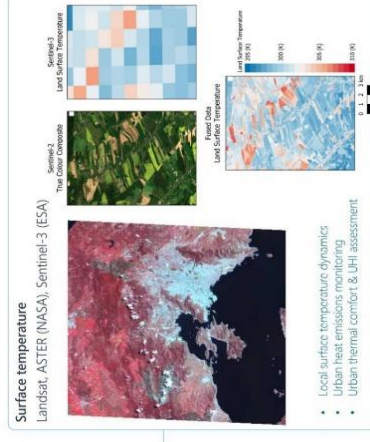

Environmental Monitoring

Urban Exposure index-Piraeus example



Atmospheric Chemistry Monitoring

CO₂, Methane, PM_{2.5}, Ozone, Aerosol

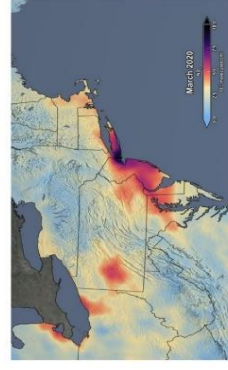
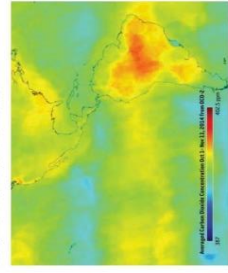

Enhanced urban air quality and weather monitoring facilitate in the improvement of citizens quality of life

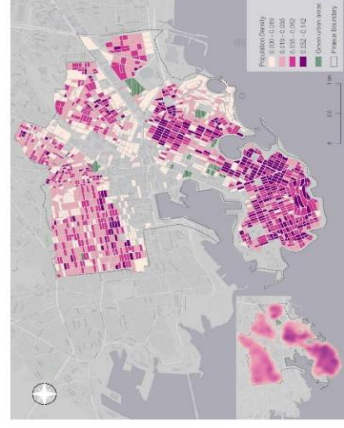

Population Density (pop./m²)

- Source: Hellenic Statistical Authority (2011 Population-Housing Census)
- Resolution: Building Block

Green urban areas
Urban Atlas 2018

Urban Exposure index-Piraeus example



Transportation & Road Network

Source: OpenStreetMap
Geofabrik (09/22)

Urban Exposure index-Piraeus example

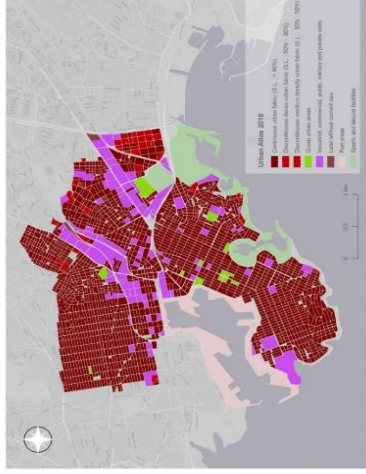

Land Use / Land Cover

Source: Copernicus Urban Atlas
2018
Resolution: Building Block
Urban Atlas 2018 provides reliable, inter-comparable, high-resolution land use and land cover data with integrated population estimates.

Urban Exposure index-Piraeus example

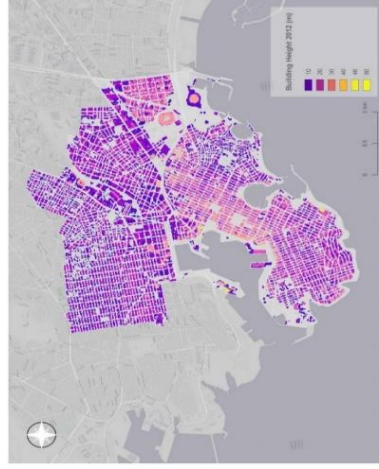

Building Height 2012 (meters)

Source: Urban Atlas

Urban Exposure index-Piraeus example

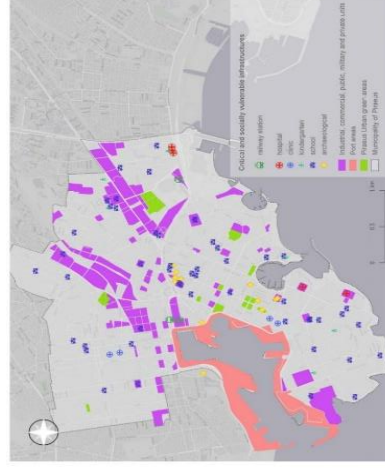

Critical & vulnerable infrastructures

Source:
Points
OpenStreetMap -
Geofabrik (09/22)

Land Use
Urban Atlas 2018

Urban Exposure index-Piraeus example

Urban Exposure index-Piraeus example

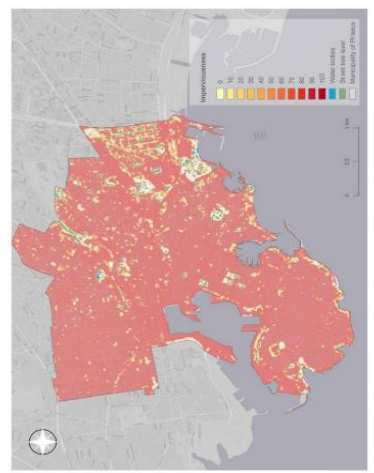

Imperviousness Density (IMD) 2018
 Source: Copernicus
 Sp. Resolution: 10m
 The imperviousness degree is a thematic product showing the occurrence of water and wet surfaces over the period from 2012 to 2018. (including data from 2017-2019) for the EEA-39 area.

Water bodies (Water & Wetness 2018)
 Source: Copernicus
 Sp. Resolution: 10m
 The combined Water and Wetness product is a thematic product showing the occurrence of water and wet surfaces over the period from 2012 to 2018.

Street Tree Layer (STL) 2018
 Source: Urban Atlas
 Sp. Resolution: 10m
 It includes continuous rows or a patches of trees covering 500 m² or more and with a minimum width of 10 meter over "Artificial surfaces" (i.e. rows of trees along the road network outside urban areas or forest adjacent



Digital Elevation Model
 Source: Eurostat (Copernicus)
 Sp. Resolution: 10m
 Vertical accuracy of 2.9m



HARMONIA Resilience DSS components

Urban Exposure index-Piraeus example

- Risk and Impact assessment:**
mapping of urban risks with synergies from multiple WPs
- Vulnerability Assessment and Urban Resilience:**
Offer scalable, practical, easy-to-implement tools for incident management and resilience investments
- Decision Support System:**
Hazard mitigation & adaptation, Urban planning, Health & well-being

HARMONIA Resilience Decision Support System (DSS)
 Clear and precise Risk-Mitigation benefits which facilitate the Decision Makers and relevant stakeholders

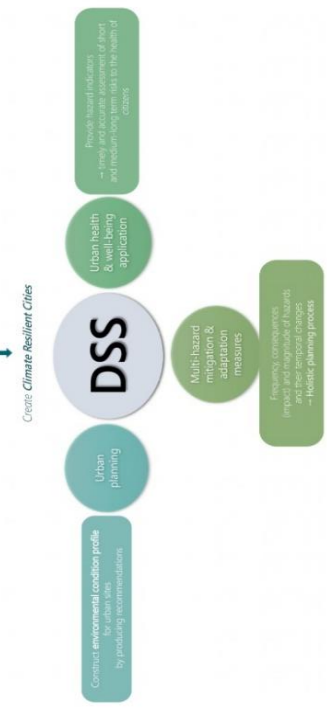



Future with Harmonia

GIVE YOUR OPINIONS ON CLIMATE CHANGES IN OUR PILOT CITIES: JOIN THE HARMONIA CITIZEN OBSERVATORY

Launch of Citizen Observatory in pilot cities to collect citizen-based data

Meet Harmonia for events and workshops

Follow our website and get involved with your community, municipality, organization





The HARMONIA project has received funding from the EU Horizon 2020 research and innovation programme under agreement No. 101003517.



FINAL OUTCOMES

Harmonia aims to unite all relevant stakeholders around the issue of Climate Change

The HARMONIA platform will be user friendly and allow stakeholders to not only understand but also visualize the impact of CC across different environments.

This will enhance cities' preparedness to respond to specific predictions, such as floods or dust storms, and protect their residents and assets.





HARMONIA



<https://harmonia-project.eu>

[The Harmonia project](https://www.facebook.com/HarmoniaProject)

[@ProjectHarmonia](https://www.instagram.com/ProjectHarmonia)

[@HarmoniaProject](https://twitter.com/HarmoniaProject)



The HARMONIA project has received funding from the EU Horizon 2020 research and innovation programme under agreement No. 101003517.

Using Earth Observation Application to Air Quality in Addition to in-situ monitoring: HARMONIA IRAP platform

Julia Nerantzia TZORTZI¹, Associate Prof.,
Anastasios DOULAMIS², Associate Prof.,
Ozge OGUT^{1,3*}, PhD Candidate,
Maria Stella LUX¹, PhD Candidate,
Ioannis TZORTZIS², PhD Candidate,
Anastasios TEMENOS², PhD Candidate,
Ioannis RALLIS², Doctor

¹Politecnico di Milano, Milan, Italy

²National Technical University of Athens, Greece

³Norwegian University of Science and Technology, Trondheim, Norway

* *Contact details of corresponding author*

Tel: +39 3471002918

e-mail: ozge.ogut@polimi.it

Address: Building 5, piazza Leonardo Da Vinci, 42, 20133 Milan.

Abstract

The effect of air quality (AQ) on public health after the COVID-19 pandemic attracted more attention although this undeniable link was studied before. Such diseases caused or accelerated by the air pollution levels has a long list including respiratory, cardiovascular, and lung disease. There are different associations between air pollution and the diseases i.e., long-term, short-term exposure and finally higher levels of air pollution. To improve a healthy environment in urban areas, increasing AQ is a must and in-situ monitoring is one method to track it. To combine in-situ monitored data and earth observation (EO) data could provide an efficient way to collect data in different temporal resolution, analyze, detect any existing anomalies, eventually provide a model for possible scenarios through climate change. This paper will discuss the benefits and challenges lie under the combination of in-situ and EO data in this framework. It will present the suggested integrated resilience assessment platform (IRAP) that is under development in the HARMONIA project (in respond to the topic LC-CLA-19-2020 and its added value on this field. The IRAP platform will eventually utilize the GEOSS datasets, along with other data collections, and adopt proper Deep Learning techniques in an effort to build robust, comprehensive data cube objects, which are considered to be the state-of-the-art solution to store and organize EO data. Information extracted from the datacubes will be visualized in the integrated graphical user interface of the platform in order to inform municipalities and citizens for potential climate change related risks and vulnerabilities.

Keywords: earth observation, in-situ data, air pollution, climate change, datacubes.

References

- Guo H.-D., Zhang L., & Zhu L.-W., 2015. Earth observation big data for climate change research. *Advances in Climate Change Research*, 6(2), 108–117. doi:10.1016/j.accre.2015.09.007.
- Kansakar P., & Hossain F., 2016. A review of applications of satellite earth observation data for global societal benefit and stewardship of planet earth. *Space Policy*, 36, 46–54. doi:10.1016/j.spacepol.2016.05.00.
- Anderson K., Ryan B., Sonntag W., Kavvada A., & Friedl L., 2017. Earth observation in service of the 2030 Agenda for Sustainable Development. *Geo-Spatial Information Science*, 20(2), 77–96. doi:10.1080/10095020.2017.1333230.
- Maurya Neeraj K., Prem C. Pandey, Subhadip Sarkar, Rajesh Kumar, and Prashant K. Srivastava, 2022. "Spatio-Temporal Monitoring of Atmospheric Pollutants Using Earth Observation Sentinel 5P TROPOMI Data: Impact of Stubble Burning a Case Study" *ISPRS International Journal of Geo-Information* 11, no. 5: 301. <https://doi.org/10.3390/ijgi11050301>.
- D'Amato G., & Cecchi L., 2008. Effects of climate change on environmental factors in respiratory allergic diseases. *Clinical & Experimental Allergy*, 38(8), 1264–1274. doi:10.1111/j.1365-2222.2008.03033.x.

15th International Scientific Conference on Energy and Climate Change
 12 - 14 October 2022, Athens, Greece

Using Earth Observation Application to Air Quality in Addition to in-situ monitoring:
 HARMONIA IRAP platform



Julia Nerantzia TZORTZI, Associate Prof. - POLIMI
 Anastasios Doullamis, Associate Prof. - NTUA
 Ozge OGUJ, PhD Candidate - POLIMI
Maria Stella LUX, PhD Candidate - POLIMI
 Ioannis TZORTZIS, PhD Candidate - NTUA
 Anastasios TEMENOS, PhD Candidate - NTUA
 Ioannis RALLIS, Doctor - NTUA

Project funded in the Horizon 2020 Programme under Grant Agreement 101005517

1

Using Earth Observation Application to Air Quality in Addition to in-situ monitoring: HARMONIA IRAP platform



Air Quality
 a threat for urban health

3 different determined association:

- Long-term exposure
- Short-term exposure
- Exposure to high levels of pollution



Air pollution in Milan, BBC

2

Using Earth Observation Application to Air Quality in Addition to in-situ monitoring: HARMONIA IRAP platform



Air Quality
 a threat for urban health

- stroke,
- chronic obstructive pulmonary disease,
- trachea,
- bronchus and lung cancers,
- aggravated asthma
- lower respiratory infections
- premature mortality

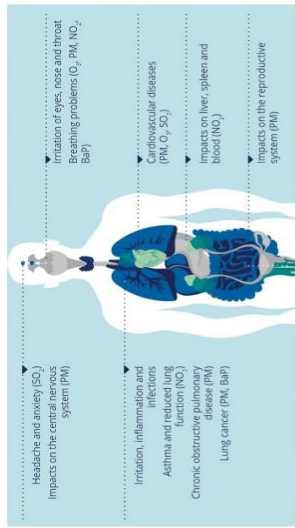

EEA, Healthy environment, healthy lives (2019)

3

Using Earth Observation Application to Air Quality in Addition to in-situ monitoring: HARMONIA IRAP platform



Air Quality
 a threat for urban health

- High air pollution increases vulnerability to **COVID-19** by affecting the respiratory system.
- The virus remains in the polluted air longer.
- Pollutants carry several chemical and biological pollutants into the respiratory system.

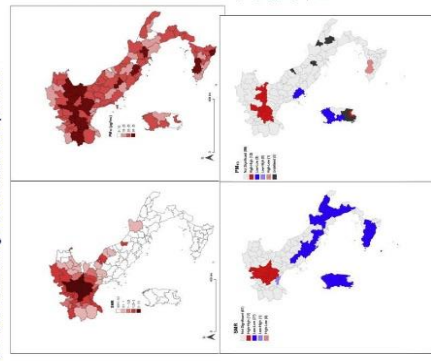

Standardized Mortality Ratio per Italian Province and PM10 level per Italian provinces

Analysis of Spatial Autocorrelation – USA, SMR and PM10

M.Dettori et. al. (2021). Air pollutants and risk of death due to COVID-19 in Italy. Environmental Research, 192: 110459, <https://doi.org/10.1016/j.envres.2020.110459>.

4

Using Earth Observation Application to Air Quality in Addition to in-situ monitoring: HARMONIA IRAP platform



An integrated approach Multi-hazard model

Greenness indicators

- Heat fluxes
- Air Quality
- Flash floodings
- Demography
- Urban morphology



I.R.A.P.

Integrated Resilience
Assessment Platform

5

Using Earth Observation Application to Air Quality in Addition to in-situ monitoring: HARMONIA IRAP platform



Complementary visions from the bottom / from the top

In-situ

Better resolution

Local factors

Validation of EO monitoring systems and forecasting models (especially regional models)

Focused monitoring in critical areas



EO

Holistic vision

Global factors

Comprehensive global monitoring and forecasting system (e.g. Copernicus: 5-day forecast)

+ regional models are (4-day forecasts)

Different depth of measurements (troposphere, stratosphere)



Emitted pollutants are dispersed and thus diluted through the whole atmosphere, but both the emissions and the exposure all take place close to the surface of the earth - where in situ measurements are recorded.

7

Using Earth Observation Application to Air Quality in Addition to in-situ monitoring: HARMONIA IRAP platform



Air data meteorological & pollution

Meteorological data

- Precipitation (mm)
- Global radiation (kWh/m2)
- W/ind (m/s; °)
- T(°C)
- RH(%)

Health-related data (pphm, ppm; µg/m3)

- PM10
- PM2.5
- O3
- NO2
- S02

Climate change-related data

- CH4 (m3/s)
- GHGs (ppm)
- CO2

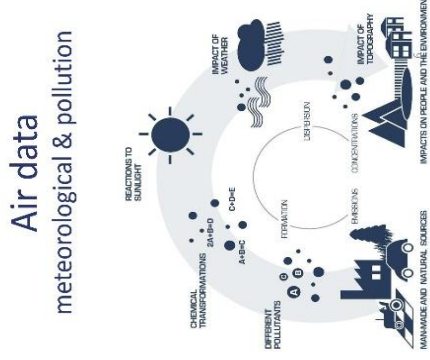

Using Earth Observation Application to Air Quality in Addition to in-situ monitoring: HARMONIA IRAP platform

Using Earth Observation Application to Air Quality in Addition to in-situ monitoring: HARMONIA IRAP platform



In-situ monitoring network

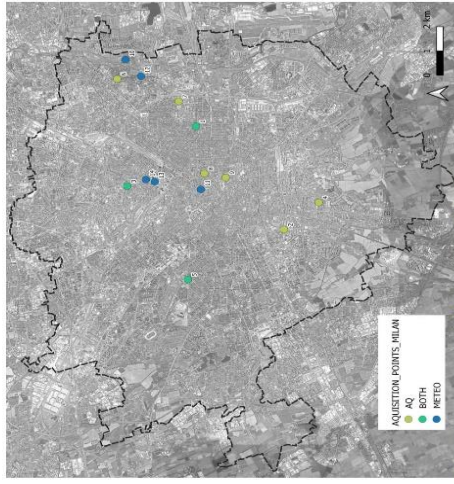

Monitoring network in Milan (DABC, POLIMI)

Using Earth Observation Application to Air Quality in Addition to in-situ monitoring: HARMONIA IRAP platform

Using Earth Observation Application to Air Quality in Addition to in-situ monitoring: HARMONIA IRAP platform

In-situ monitoring network
SOPIA, BULGARIA

HARMONIA IRAP platform logo

Monitoring network in Sofia (DABC, POLIMI)

Using Earth Observation Application to Air Quality in Addition to in-situ monitoring: HARMONIA IRAP platform

In-situ monitoring network
ATHENS, GREECE

HARMONIA IRAP platform logo

Monitoring network in Piraeus (DABC, POLIMI)

Using Earth Observation Application to Air Quality in Addition to in-situ monitoring: HARMONIA IRAP platform

Earth Observation global monitoring

- Urban landscape monitoring
- Environmental monitoring

Implement a risk analysis, identifying the vulnerability areas related to hazards

SDG 11: Sustainable Cities and Communities
 SDG 13: Climate Action

HARMONIA IRAP platform logo

Using Earth Observation Application to Air Quality in Addition to in-situ monitoring: HARMONIA IRAP platform

Using Earth Observation Application to Air Quality in Addition to in-situ monitoring: HARMONIA IRAP platform

Earth Observation Application to Air Quality in Addition to in-situ monitoring: HARMONIA IRAP platform

Seninel-5P Nitrogen Dioxide Tropospheric column
 0 ppb/m³ 300 ppb/m³
 January February March

Nitrogen dioxide emissions drop over Italy across Europe in 1 January 2020 (on the left) and 11 March 2020 (on the right) (data from the Copernicus Sentinel-5P satellite, European Space Agency (ESA))

HARMONIA IRAP platform logo

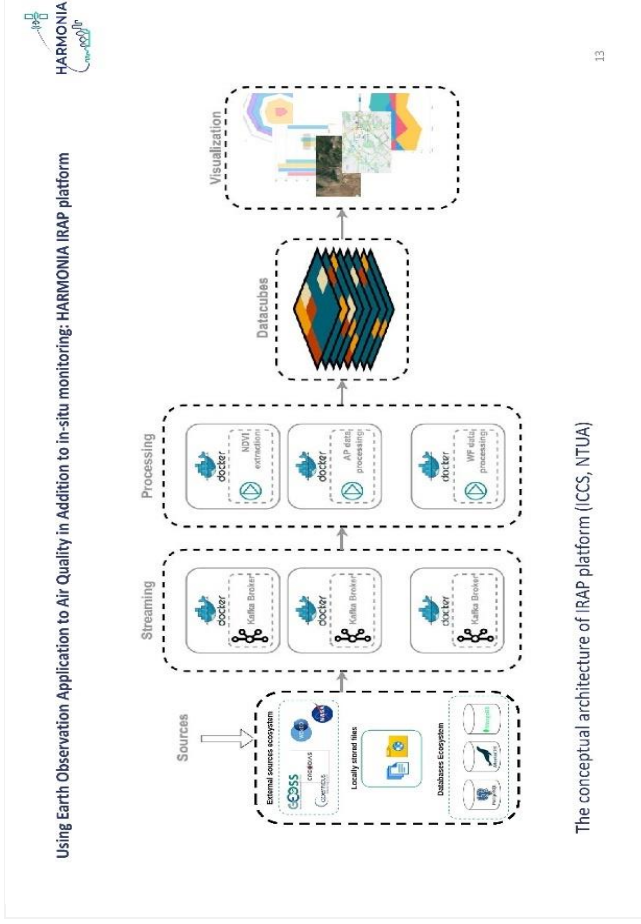

13



The Regional Climate Adaptation Plan of Crete as a strategic planning cornerstone for the protection of the natural environment and the resilience of infrastructure in a climate hotspot area

Christos TSOMPANIDIS,
Theofanis LOLOS,
Konstantina PASCHALI - MANOU,
Antonios SAKALIS*,
Eleni IEREMIADI,
Evangelia VLACHANTONI,
ENVIROPLAN Consultants & Engineers S.A., Greece

Stella KAIMAKI,
ADENS S.A., Greece

Eleni KARGAKIS,
Marinos KRITSOTAKIS,
Region of Crete – Department of Environment and Spatial Planning, Greece

** Contact details of corresponding author*
e-mail: ct@enviroplan.gr; info@enviroplan.gr

ENVIROPLAN Consultants & Engineers S.A., 23 Perikleous & Iras Str., 15344, Gerakas, Athens, Greece

Abstract

The present work is related to the Regional Climate Adaptation Plan of Crete. The Region has been identified as a climate hotspot in various studies. Alarmingly, the Greek National Climate Adaptation Strategy, identified Crete, as the most vulnerable Region to climate change in Greece. In response to this emergency, the Region of Crete announced a tender, funded by the Crete Regional Development Fund, for the development of its first Regional Climate Adaptation Plan. The project was awarded to the Consortium: ENVIROPLAN S.A. and ADENS S.A. The plan has been elaborated and is currently under institutionalization. This paper presents an overview of the efforts to identify and prioritize the necessary actions for the adaptation of Crete to climate change. In accordance with legislative requirements, a trend analysis was performed for key climate indices, based on climate projections from internationally recognized regional climate models, in a spatial resolution of 12.5km x 12.5km. The trend analysis was performed for short-term (2021-2040), medium-term (2041-2060) and long-term (2081-2100) time horizons, for two scenarios of global evolution of greenhouse gas concentrations (RCP4.5 and RCP8.5) according to the 5th IPCC Assessment Report. Climate change was estimated in relation to the corresponding values for the period 1981-2000 (reference period). Also, changes of extreme phenomena (floods, heat waves, droughts, windstorms etc.) in the Region were studied. Afterwards, taking into account the expected climate change, vulnerability assessment for 13 key sectors of the economy and the natural environment was performed. The expected sectors and geographic areas to be affected, were identified. Based on the sectoral and spatial priorities identified, measures and actions to avoid, mitigate or restore the impacts of climate change were proposed, analyzed and prioritized. Implementation bodies, funding sources and indicative budget were also identified. The plan will be the guide for the Region and shall support the preparation and maturation of many projects that will be included in the new programming period.

Keywords: Region of Crete, Strategic Planning, Climate Change, Adaptation, Vulnerability.



15th International Scientific Conference on Energy and Climate Change
Athens, 12-14 October 2022



The Regional Climate Adaptation Plan of Crete as a strategic planning cornerstone for the protection of the natural environment and the resilience of infrastructure in a climate hotspot area



C. Tsompanidis, T. Lolos, K. Paschali – Manou, A. Sakalis, E. Ieremiadi, E. Vlachantoni, S. Kaimaki, E. Kargakis, M. Kritsotakis



15th International Scientific Conference on Energy and Climate Change
Athens, 12-14 October 2022



ENVIROPLAN S.A. offers a broad range of services from the initial concept through to the commissioning of a project, specialized in multi-disciplinary solutions.

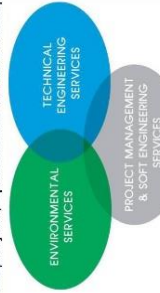

ENVIROPLAN S.A. has over 30 years of experience and expertise in Waste Management projects, providing consultancy and technical engineering services.



15th International Scientific Conference on Energy and Climate Change
Athens, 12-14 October 2022



ENVIROPLAN Consultants and Engineers S.A.

private consulting firm, founded in Athens in 1990

Headquarters Offices Athens/ Greece



H ENVIROPLAN A.E. is certified according to EN ISO 9001:2015, EN ISO 14001:2015, EN ISO 45001:2018 and EN ISO 27001:2013 and holds also a permanent professional Indemnity Insurance Contract with XI Insurance Company SE (AXA XL Group).



CERTIFIED M.S.
ISO 9001:2015
10726/Α
ISO 14001:2015
10707/Α
ISO 45001:2018
0005030921
ISO 27001:2013
0016330248



15th International Scientific Conference on Energy and Climate Change
Athens, 12-14 October 2022













ENVIROPLAN S.A. is involved in many international environmental projects in:

- ✓ Italy
- ✓ Bulgaria
- ✓ Ukraine
- ✓ Egypt
- ✓ Cyprus
- ✓ North Macedonia
- ✓ Kyrgyz Republic
- ✓ Palestine
- ✓ Turkey
- ✓ Georgia
- ✓ Jordan
- ✓ Montenegro
- ✓ Romania
- ✓ Azerbaijan
- ✓ Lebanon
- ✓ Maldives
- ✓ Croatia
- ✓ Armenia
- ✓ Lithuania
- ✓ Indonesia
- ✓ Serbia

ENVIROPLAN S.A. has as clients many international organizations as well as governmental bodies such as:

- ✓ World Bank (WB)
- ✓ European Investment Bank (EIB)
- ✓ European Bank for Reconstruction and Development (EBRD)
- ✓ Joint Assistance to Support Projects in European Regions (JASPERS)
- ✓ Ministries
- ✓ Waste Management Organizations
- ✓ Local Authorities
- ✓ Private sector

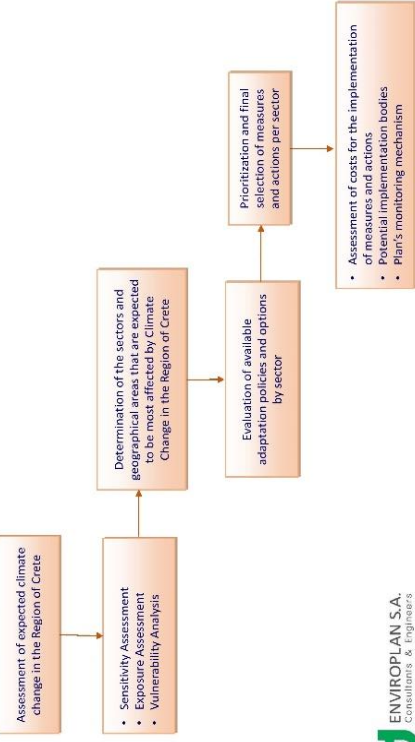

 <p>15th International Scientific Conference on Energy and Climate Change Athens, 12-14 October 2022</p> <p>Climate Change</p> <p>Climate change has been taking place since the end of the 19th century and its impacts are increasingly being noticeable in Europe and worldwide</p> <p>According to the World Economic Forum's 2022 Global Risks Report, two of the five most serious global risks are related to climate change and include extreme weather events, and the failure to adapt to climate change (climate action failure)</p> <p>Temperature rise is the most significant change and is directly related to anthropogenic greenhouse gas emissions</p> <p>Direct impact of this continuous increase in temperature is the melting of the polar ice caps And as a result, sea level rise</p> <p>Other important changes in the global climate include changes in the amount of precipitation and the more frequent occurrence of extreme weather events such as droughts, heat waves, floods, hurricanes, storms, etc.</p> 	 <p>15th International Scientific Conference on Energy and Climate Change Athens, 12-14 October 2022</p> <p>Little bit of history</p> <p>History of Climate Adaptation in Greece</p> <ul style="list-style-type: none"> ➤ Interdisciplinary Committee on Climate Change Impact Assessment (EMEKA) of the Bank of Greece (2011) ➤ Greek National Climate Adaptation Strategy (NAS) (2016) ➤ Law 4414/2016 (Government Gazette 149/A/09-08-2016) ➤ Ministerial Decree 11258/2017 (Government Gazette 873/B/16-03-2017) ➤ Climate Law 4936/2022 (Government Gazette 105/A/27-05-2022) 
 <p>15th International Scientific Conference on Energy and Climate Change Athens, 12-14 October 2022</p> <p>The Regional Climate Change Adaptation Plan of Crete</p> <p>Elaborated as a legal obligation of the Region of Crete and supports the protection of Crete against:</p> <ul style="list-style-type: none"> ➤ Temperature rise ➤ Decrease of precipitation ➤ Increase in the frequency and intensity of extreme weather events (floods, drought, windstorms, heatwaves, cold invasions/frosts, storm surges, etc.) ➤ Sea level rise  <p>Flood in Gournes (Gournes Municipality) (June 2021)</p>  <p>Forest fire in Gournes (Gournes Municipality) (June 2021)</p>  <p>Landslide phenomenon in the Prefecture of Chania due to extreme weather events (February 2019)</p> 	 <p>15th International Scientific Conference on Energy and Climate Change Athens, 12-14 October 2022</p> <p>Development Steps of the Crete Climate Change Adaptation Plan</p>  

15th International Scientific Conference on Energy and Climate Change
Athens, 12-14 October 2022

Climate Change in Crete (1)

- ✓ An increase in average temperature is expected at the Region, in all scenarios and time horizons
- In short term (2021-2040) mean temperature rise ranges between 1.35°C and 2.41°C
- Slightly larger increase in inland and mountainous areas & smaller in coastal areas
- Higher increase during the summer period compared to the whole year



✓ Electricity demand for cooling (through the index of CDD) is expected to increase (opposed to energy demand for heating)



✓ Growth season is expected to be extended by 22 days/year (Positive impact, however, needs to be correlated with water availability)

✓ Number of days with a very likely occurrence of fire (FWI index), increased by approximately 40 days (worst case scenario).

15th International Scientific Conference on Energy and Climate Change
Athens, 12-14 October 2022

Climate Change in Crete

Mean Temperature Rise

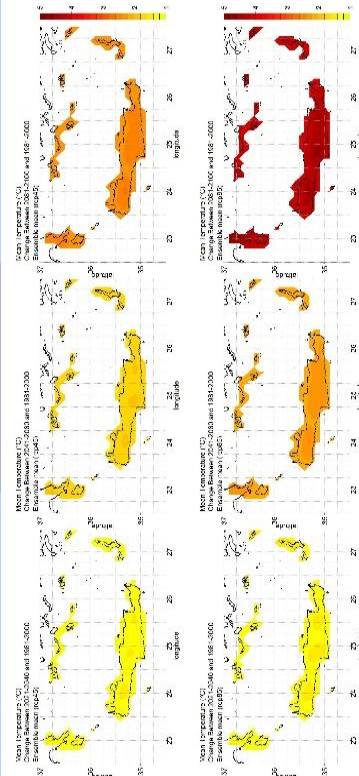

Mean Temperature Rise (°C) Change Between 2021-2040 and 1981-2010

Mean Temperature Rise (°C) Change Between 2041-2060 and 1981-2010

Mean Temperature Rise (°C) Change Between 2081-2100 and 1981-2010



15th International Scientific Conference on Energy and Climate Change
Athens, 12-14 October 2022

Climate Change in Crete

Increase in days with forest fire risk

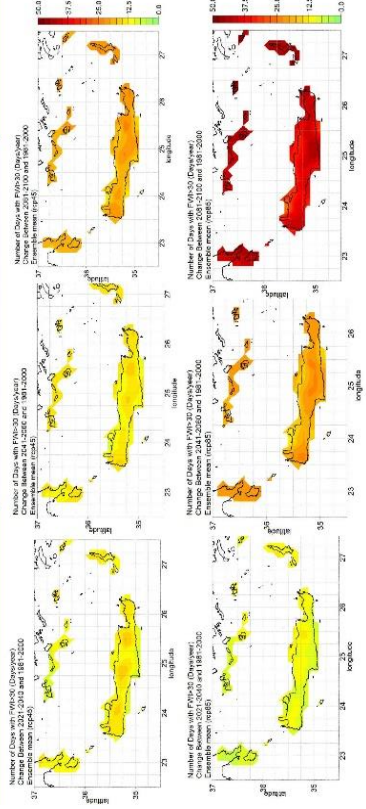

Number of Days with FWI > 30 (Dryness) Change Between 2021-2040 and 1981-2010

Number of Days with FWI > 30 (Dryness) Change Between 2041-2060 and 1981-2010

Number of Days with FWI > 30 (Dryness) Change Between 2081-2100 and 1981-2010



15th International Scientific Conference on Energy and Climate Change
Athens, 12-14 October 2022

Climate Change in Crete (2)

- ✓ Gradual decrease in precipitation (both scenarios)
- Highest decrease in mean precipitation value (Region as a whole) by 187mm (27%) in the period 2081-2100 (worst-case scenario)
- Increase in consecutive days without precipitation from about 5 to 25 days (droughts)
- Highest change of continuous dry days in Heraklion Prefecture (30 days/year, time horizon 2081-2100).









- ✓ In terms of wind (mean and maximum) no significant change is expected
- The number of days (during fire fighting season) with an average wind speed of more than 66 is unchanged - NE Crete is an exception (up to 20 additional days in the future)
- ✓ The incoming short-wavelength radiation reaching the surface will show a relatively small increase
- In the mountains significantly larger average annual increase (up to 8 Watt/m²).

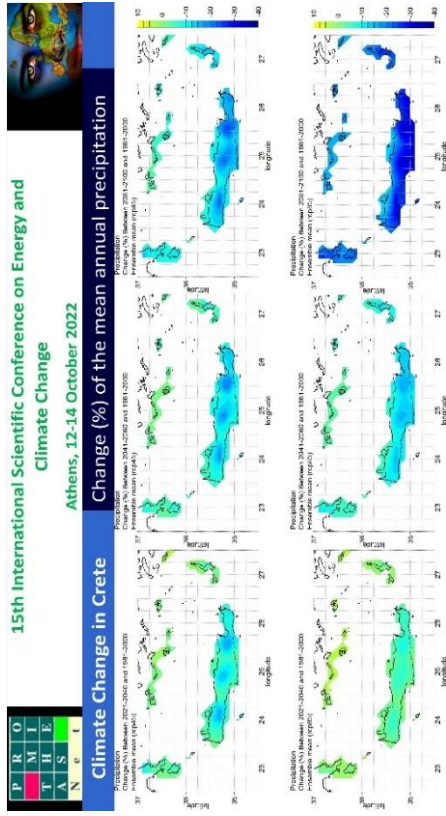

- ✓ The number of days when the **maximum temperature will exceed 35°C** will increase from 3 days (two scenarios, near future) to 22 days (worst-case scenario, long term)
- Increase in number of days with a **maximum temperature above 37°C** on average (total Region) from 1.5 days (two scenarios, near future) to 10 days (worst-case scenario, long term)
- Greater change in days with a **maximum temperature above 35°C** (RCP8.5 scenario, far future) in the Municipalities of **Phalstos and Gortyna** (increase > 30 days/year)
- Similar degree of increase for days with maximum temperature > 37°C.

- ✓ Higher increase in the **number of days with Tmin > 20°C (tropical nights)** in the coming decades, on average from 25 days (two scenarios, period 2021-2040) to 80 days (worst-case scenario, period 2081-2100)
- ➔ Increase in the **number of days per year with great discomfort for the population**, due to changes in temperature (combined with changes in humidity)

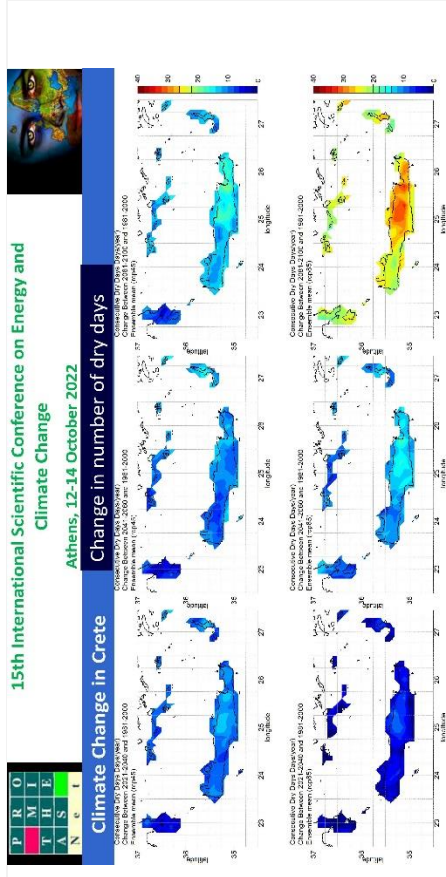

- ✓ Increase in the **maximum amount of precipitation within 24 hours & within 48 hours, up to 20%** (RCP8.5 scenario, long term horizon) in the northern coastal parts of the **Chania Prefecture**
- ✓ Lower increase in the **northern coastal parts** of the Municipalities of **Rethimno, Heraklion, Hersonissos and Agios Nikolaos**
- ➔ The above-mentioned areas will face a **greater risk of flooding in the future.**



Flash flood event following extreme precipitation in the coastal front of Gouves in the Municipality of Hersonissos (10/11/2020).





15th International Scientific Conference on Energy and Climate Change
Athens, 12-14 October 2022



Climate Change in Crete
Change (%) of the 48-hour precipitation

Maximum 48h Precipitation Per Year
Change between 1981-2020 and 1981-2050
Scenario: Intermediate (IPCC4.5)
Emission: Intermediate (IPCC4.5)

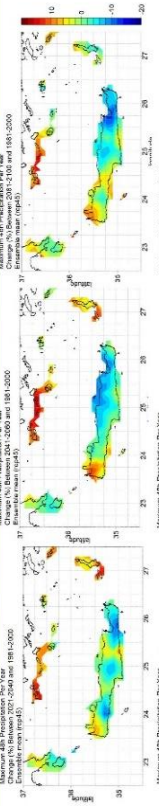

Maximum 48h Precipitation Per Year
Change between 1981-2020 and 1981-2050
Scenario: Worst-case (IPCC4.5)
Emission: Worst-case (IPCC4.5)

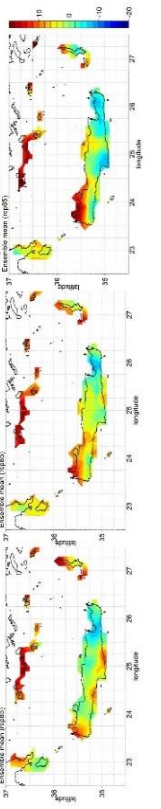

Maximum 48h Precipitation Per Year
Change between 1981-2020 and 1981-2050
Scenario: Best-case (IPCC4.5)
Emission: Best-case (IPCC4.5)



Climate Change in Crete
Change (%) of the 48-hour precipitation

Maximum 48h Precipitation Per Year
Change between 1981-2020 and 1981-2050
Scenario: Intermediate (IPCC4.5)
Emission: Intermediate (IPCC4.5)

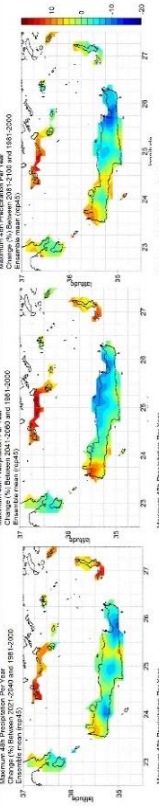

Maximum 48h Precipitation Per Year
Change between 1981-2020 and 1981-2050
Scenario: Worst-case (IPCC4.5)
Emission: Worst-case (IPCC4.5)

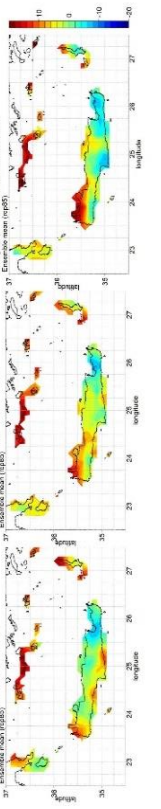

Maximum 48h Precipitation Per Year
Change between 1981-2020 and 1981-2050
Scenario: Best-case (IPCC4.5)
Emission: Best-case (IPCC4.5)





15th International Scientific Conference on Energy and Climate Change
Athens, 12-14 October 2022



Climate Change in Crete (5)



- ✓ **Reduction in days with total frost**
 - They are expected to gradually become almost extinct even in the mountains (up to 1,500 m)
 - Decrease of night frost (Tmin<0°C) in the future in all scenarios
- ✓ **Decrease of snow coverage in the coming decades (intermediate & worst-case scenario).** Time horizon 2081 – 2100, reduction up to 90% (worst-case scenario)
 - *The snow-covered areas will almost disappear in the whole of Crete up to at least 1,500m in the distant future.*



2050 sea level

- ✓ **Sea level will rise in the future**
 - Maximum rise value from 15cm (period 2021-2040) to 60-70 cm (long term), in the intermediate and worst-case scenario respectively
 - The coastal areas of northern Crete are at greater risk (increase > 0.75 m in the worst-case scenario in the long-term time horizon)



15th International Scientific Conference on Energy and Climate Change
Athens, 12-14 October 2022



Climate Change in Crete
Sea level rise

Extreme Sea Level Rise (m)
Change between 1981-2020 and 1981-2050
Scenario: Intermediate (IPCC4.5)
Emission: Intermediate (IPCC4.5)

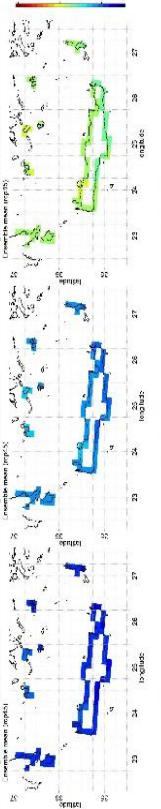

Extreme Sea Level Rise (m)
Change between 1981-2020 and 1981-2050
Scenario: Worst-case (IPCC4.5)
Emission: Worst-case (IPCC4.5)

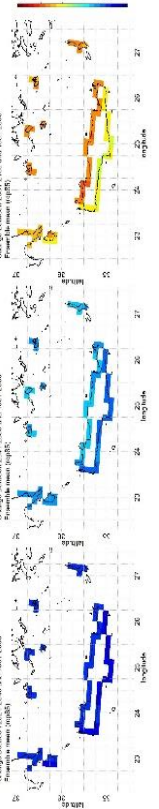

Extreme Sea Level Rise (m)
Change between 1981-2020 and 1981-2050
Scenario: Best-case (IPCC4.5)
Emission: Best-case (IPCC4.5)



Climate Change in Crete
Sea level rise

Extreme Sea Level Rise (m)
Change between 1981-2020 and 1981-2050
Scenario: Intermediate (IPCC4.5)
Emission: Intermediate (IPCC4.5)

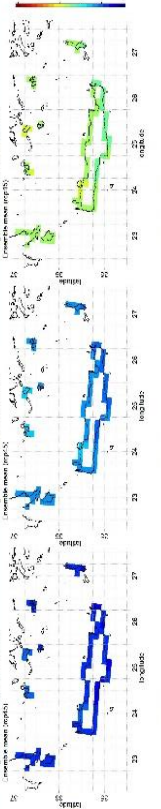

Extreme Sea Level Rise (m)
Change between 1981-2020 and 1981-2050
Scenario: Worst-case (IPCC4.5)
Emission: Worst-case (IPCC4.5)

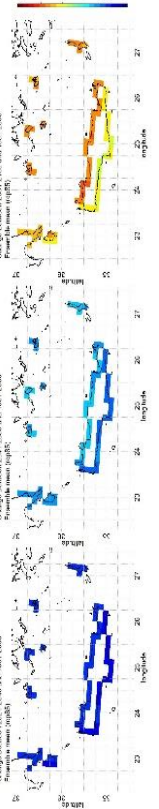

Extreme Sea Level Rise (m)
Change between 1981-2020 and 1981-2050
Scenario: Best-case (IPCC4.5)
Emission: Best-case (IPCC4.5)





15th International Scientific Conference on Energy and Climate Change
Athens, 12-14 October 2022



Vulnerability Assessment Methodology

STEP 1: Selection of the sectors for which the vulnerability assessment will be performed

STEP 2: Selection of the appropriate indices to evaluate the impact of each climate impact driver to each sector*

STEP 3: Sensitivity analysis of each sector to climate change

STEP 4: Exposure analysis for each sector to climate change

STEP 5: Vulnerability assessment of the different sectors and geographic areas

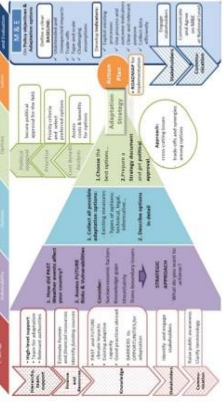

* The climate impact drivers for which the vulnerability assessment was carried under this assignment are:

- Temperature rise;
- Drought;
- Windstorms;
- Heat waves;
- Cold invasions / frost;
- Extreme precipitation;
- Snowcover decrease and
- Sea level rise.



15th International Scientific Conference on Energy and Climate Change
Athens, 12-14 October 2022



Sectors under evaluation

- **Agricultural and livestock production**
 - Agriculture
 - Livestock
- **Forests and Reforested Areas**
 - Forests
 - Reforested Areas
- **Biodiversity and Ecosystems**
- **Fisheries and Aquaculture**
 - Fisheries
 - Aquaculture
- **Water Resources (availability of water resources)**
- **Rivers (flood events)**





15th International Scientific Conference on Energy and Climate Change
Athens, 12-14 October 2022



Selection of the appropriate indices to evaluate the impact of each climate impact driver to each sector



Climate impact driver	Appropriate index	Appropriate index
Sea level rise (SLR)	Sea level rise (SLR)	Sea level rise (SLR)
Sea level rise (SLR) - 0.1m	Sea level rise (SLR) - 0.1m	Sea level rise (SLR) - 0.1m
Sea level rise (SLR) - 0.2m	Sea level rise (SLR) - 0.2m	Sea level rise (SLR) - 0.2m
Sea level rise (SLR) - 0.3m	Sea level rise (SLR) - 0.3m	Sea level rise (SLR) - 0.3m
Sea level rise (SLR) - 0.4m	Sea level rise (SLR) - 0.4m	Sea level rise (SLR) - 0.4m
Sea level rise (SLR) - 0.5m	Sea level rise (SLR) - 0.5m	Sea level rise (SLR) - 0.5m
Sea level rise (SLR) - 0.6m	Sea level rise (SLR) - 0.6m	Sea level rise (SLR) - 0.6m
Sea level rise (SLR) - 0.7m	Sea level rise (SLR) - 0.7m	Sea level rise (SLR) - 0.7m
Sea level rise (SLR) - 0.8m	Sea level rise (SLR) - 0.8m	Sea level rise (SLR) - 0.8m
Sea level rise (SLR) - 0.9m	Sea level rise (SLR) - 0.9m	Sea level rise (SLR) - 0.9m
Sea level rise (SLR) - 1.0m	Sea level rise (SLR) - 1.0m	Sea level rise (SLR) - 1.0m
Sea level rise (SLR) - 1.1m	Sea level rise (SLR) - 1.1m	Sea level rise (SLR) - 1.1m
Sea level rise (SLR) - 1.2m	Sea level rise (SLR) - 1.2m	Sea level rise (SLR) - 1.2m
Sea level rise (SLR) - 1.3m	Sea level rise (SLR) - 1.3m	Sea level rise (SLR) - 1.3m
Sea level rise (SLR) - 1.4m	Sea level rise (SLR) - 1.4m	Sea level rise (SLR) - 1.4m
Sea level rise (SLR) - 1.5m	Sea level rise (SLR) - 1.5m	Sea level rise (SLR) - 1.5m
Sea level rise (SLR) - 1.6m	Sea level rise (SLR) - 1.6m	Sea level rise (SLR) - 1.6m
Sea level rise (SLR) - 1.7m	Sea level rise (SLR) - 1.7m	Sea level rise (SLR) - 1.7m
Sea level rise (SLR) - 1.8m	Sea level rise (SLR) - 1.8m	Sea level rise (SLR) - 1.8m
Sea level rise (SLR) - 1.9m	Sea level rise (SLR) - 1.9m	Sea level rise (SLR) - 1.9m
Sea level rise (SLR) - 2.0m	Sea level rise (SLR) - 2.0m	Sea level rise (SLR) - 2.0m
Sea level rise (SLR) - 2.1m	Sea level rise (SLR) - 2.1m	Sea level rise (SLR) - 2.1m
Sea level rise (SLR) - 2.2m	Sea level rise (SLR) - 2.2m	Sea level rise (SLR) - 2.2m
Sea level rise (SLR) - 2.3m	Sea level rise (SLR) - 2.3m	Sea level rise (SLR) - 2.3m
Sea level rise (SLR) - 2.4m	Sea level rise (SLR) - 2.4m	Sea level rise (SLR) - 2.4m
Sea level rise (SLR) - 2.5m	Sea level rise (SLR) - 2.5m	Sea level rise (SLR) - 2.5m
Sea level rise (SLR) - 2.6m	Sea level rise (SLR) - 2.6m	Sea level rise (SLR) - 2.6m
Sea level rise (SLR) - 2.7m	Sea level rise (SLR) - 2.7m	Sea level rise (SLR) - 2.7m
Sea level rise (SLR) - 2.8m	Sea level rise (SLR) - 2.8m	Sea level rise (SLR) - 2.8m
Sea level rise (SLR) - 2.9m	Sea level rise (SLR) - 2.9m	Sea level rise (SLR) - 2.9m
Sea level rise (SLR) - 3.0m	Sea level rise (SLR) - 3.0m	Sea level rise (SLR) - 3.0m
Sea level rise (SLR) - 3.1m	Sea level rise (SLR) - 3.1m	Sea level rise (SLR) - 3.1m
Sea level rise (SLR) - 3.2m	Sea level rise (SLR) - 3.2m	Sea level rise (SLR) - 3.2m
Sea level rise (SLR) - 3.3m	Sea level rise (SLR) - 3.3m	Sea level rise (SLR) - 3.3m
Sea level rise (SLR) - 3.4m	Sea level rise (SLR) - 3.4m	Sea level rise (SLR) - 3.4m
Sea level rise (SLR) - 3.5m	Sea level rise (SLR) - 3.5m	Sea level rise (SLR) - 3.5m
Sea level rise (SLR) - 3.6m	Sea level rise (SLR) - 3.6m	Sea level rise (SLR) - 3.6m
Sea level rise (SLR) - 3.7m	Sea level rise (SLR) - 3.7m	Sea level rise (SLR) - 3.7m
Sea level rise (SLR) - 3.8m	Sea level rise (SLR) - 3.8m	Sea level rise (SLR) - 3.8m
Sea level rise (SLR) - 3.9m	Sea level rise (SLR) - 3.9m	Sea level rise (SLR) - 3.9m
Sea level rise (SLR) - 4.0m	Sea level rise (SLR) - 4.0m	Sea level rise (SLR) - 4.0m
Sea level rise (SLR) - 4.1m	Sea level rise (SLR) - 4.1m	Sea level rise (SLR) - 4.1m
Sea level rise (SLR) - 4.2m	Sea level rise (SLR) - 4.2m	Sea level rise (SLR) - 4.2m
Sea level rise (SLR) - 4.3m	Sea level rise (SLR) - 4.3m	Sea level rise (SLR) - 4.3m
Sea level rise (SLR) - 4.4m	Sea level rise (SLR) - 4.4m	Sea level rise (SLR) - 4.4m
Sea level rise (SLR) - 4.5m	Sea level rise (SLR) - 4.5m	Sea level rise (SLR) - 4.5m
Sea level rise (SLR) - 4.6m	Sea level rise (SLR) - 4.6m	Sea level rise (SLR) - 4.6m
Sea level rise (SLR) - 4.7m	Sea level rise (SLR) - 4.7m	Sea level rise (SLR) - 4.7m
Sea level rise (SLR) - 4.8m	Sea level rise (SLR) - 4.8m	Sea level rise (SLR) - 4.8m
Sea level rise (SLR) - 4.9m	Sea level rise (SLR) - 4.9m	Sea level rise (SLR) - 4.9m
Sea level rise (SLR) - 5.0m	Sea level rise (SLR) - 5.0m	Sea level rise (SLR) - 5.0m
Sea level rise (SLR) - 5.1m	Sea level rise (SLR) - 5.1m	Sea level rise (SLR) - 5.1m
Sea level rise (SLR) - 5.2m	Sea level rise (SLR) - 5.2m	Sea level rise (SLR) - 5.2m
Sea level rise (SLR) - 5.3m	Sea level rise (SLR) - 5.3m	Sea level rise (SLR) - 5.3m
Sea level rise (SLR) - 5.4m	Sea level rise (SLR) - 5.4m	Sea level rise (SLR) - 5.4m
Sea level rise (SLR) - 5.5m	Sea level rise (SLR) - 5.5m	Sea level rise (SLR) - 5.5m
Sea level rise (SLR) - 5.6m	Sea level rise (SLR) - 5.6m	Sea level rise (SLR) - 5.6m
Sea level rise (SLR) - 5.7m	Sea level rise (SLR) - 5.7m	Sea level rise (SLR) - 5.7m
Sea level rise (SLR) - 5.8m	Sea level rise (SLR) - 5.8m	Sea level rise (SLR) - 5.8m
Sea level rise (SLR) - 5.9m	Sea level rise (SLR) - 5.9m	Sea level rise (SLR) - 5.9m
Sea level rise (SLR) - 6.0m	Sea level rise (SLR) - 6.0m	Sea level rise (SLR) - 6.0m
Sea level rise (SLR) - 6.1m	Sea level rise (SLR) - 6.1m	Sea level rise (SLR) - 6.1m
Sea level rise (SLR) - 6.2m	Sea level rise (SLR) - 6.2m	Sea level rise (SLR) - 6.2m
Sea level rise (SLR) - 6.3m	Sea level rise (SLR) - 6.3m	Sea level rise (SLR) - 6.3m
Sea level rise (SLR) - 6.4m	Sea level rise (SLR) - 6.4m	Sea level rise (SLR) - 6.4m
Sea level rise (SLR) - 6.5m	Sea level rise (SLR) - 6.5m	Sea level rise (SLR) - 6.5m
Sea level rise (SLR) - 6.6m	Sea level rise (SLR) - 6.6m	Sea level rise (SLR) - 6.6m
Sea level rise (SLR) - 6.7m	Sea level rise (SLR) - 6.7m	Sea level rise (SLR) - 6.7m
Sea level rise (SLR) - 6.8m	Sea level rise (SLR) - 6.8m	Sea level rise (SLR) - 6.8m
Sea level rise (SLR) - 6.9m	Sea level rise (SLR) - 6.9m	Sea level rise (SLR) - 6.9m
Sea level rise (SLR) - 7.0m	Sea level rise (SLR) - 7.0m	Sea level rise (SLR) - 7.0m
Sea level rise (SLR) - 7.1m	Sea level rise (SLR) - 7.1m	Sea level rise (SLR) - 7.1m
Sea level rise (SLR) - 7.2m	Sea level rise (SLR) - 7.2m	Sea level rise (SLR) - 7.2m
Sea level rise (SLR) - 7.3m	Sea level rise (SLR) - 7.3m	Sea level rise (SLR) - 7.3m
Sea level rise (SLR) - 7.4m	Sea level rise (SLR) - 7.4m	Sea level rise (SLR) - 7.4m
Sea level rise (SLR) - 7.5m	Sea level rise (SLR) - 7.5m	Sea level rise (SLR) - 7.5m
Sea level rise (SLR) - 7.6m	Sea level rise (SLR) - 7.6m	Sea level rise (SLR) - 7.6m
Sea level rise (SLR) - 7.7m	Sea level rise (SLR) - 7.7m	Sea level rise (SLR) - 7.7m
Sea level rise (SLR) - 7.8m	Sea level rise (SLR) - 7.8m	Sea level rise (SLR) - 7.8m
Sea level rise (SLR) - 7.9m	Sea level rise (SLR) - 7.9m	Sea level rise (SLR) - 7.9m
Sea level rise (SLR) - 8.0m	Sea level rise (SLR) - 8.0m	Sea level rise (SLR) - 8.0m
Sea level rise (SLR) - 8.1m	Sea level rise (SLR) - 8.1m	Sea level rise (SLR) - 8.1m
Sea level rise (SLR) - 8.2m	Sea level rise (SLR) - 8.2m	Sea level rise (SLR) - 8.2m
Sea level rise (SLR) - 8.3m	Sea level rise (SLR) - 8.3m	Sea level rise (SLR) - 8.3m
Sea level rise (SLR) - 8.4m	Sea level rise (SLR) - 8.4m	Sea level rise (SLR) - 8.4m
Sea level rise (SLR) - 8.5m	Sea level rise (SLR) - 8.5m	Sea level rise (SLR) - 8.5m
Sea level rise (SLR) - 8.6m	Sea level rise (SLR) - 8.6m	Sea level rise (SLR) - 8.6m
Sea level rise (SLR) - 8.7m	Sea level rise (SLR) - 8.7m	Sea level rise (SLR) - 8.7m
Sea level rise (SLR) - 8.8m	Sea level rise (SLR) - 8.8m	Sea level rise (SLR) - 8.8m
Sea level rise (SLR) - 8.9m	Sea level rise (SLR) - 8.9m	Sea level rise (SLR) - 8.9m
Sea level rise (SLR) - 9.0m	Sea level rise (SLR) - 9.0m	Sea level rise (SLR) - 9.0m
Sea level rise (SLR) - 9.1m	Sea level rise (SLR) - 9.1m	Sea level rise (SLR) - 9.1m
Sea level rise (SLR) - 9.2m	Sea level rise (SLR) - 9.2m	Sea level rise (SLR) - 9.2m
Sea level rise (SLR) - 9.3m	Sea level rise (SLR) - 9.3m	Sea level rise (SLR) - 9.3m
Sea level rise (SLR) - 9.4m	Sea level rise (SLR) - 9.4m	Sea level rise (SLR) - 9.4m
Sea level rise (SLR) - 9.5m	Sea level rise (SLR) - 9.5m	Sea level rise (SLR) - 9.5m
Sea level rise (SLR) - 9.6m	Sea level rise (SLR) - 9.6m	Sea level rise (SLR) - 9.6m
Sea level rise (SLR) - 9.7m	Sea level rise (SLR) - 9.7m	Sea level rise (SLR) - 9.7m
Sea level rise (SLR) - 9.8m	Sea level rise (SLR) - 9.8m	Sea level rise (SLR) - 9.8m
Sea level rise (SLR) - 9.9m	Sea level rise (SLR) - 9.9m	Sea level rise (SLR) - 9.9m
Sea level rise (SLR) - 10.0m	Sea level rise (SLR) - 10.0m	Sea level rise (SLR) - 10.0m

The purpose of this Step is to assess the sensitivity that is expected for every sector in each climate impact driver









The assessment in the context of the study was based on the feedback from the extensive stakeholders engagement that was performed and consultations that took place, and literature review (Studies, papers etc. from Greek and international literature that focus on how climate change impacts the various sectors).

- Based on the above information, we developed a sensitivity matrix for each sector and climate impact driver. Calculation of sensitivity was based on the following normalized scale:
- ✓ **Negligible sensitivity:** 0
 - ✓ **Low sensitivity:** 1
 - ✓ **Medium sensitivity:** 2
 - ✓ **High sensitivity:** 3
 - ✓ **Very high sensitivity:** 4
- For example, water resources sector is very sensitive to droughts, due to reduced water supply and renewal of the aquifers, increased water demand, etc. compared to the fisheries sector, which is not affected. Conversely, water resources are not affected by heat waves, they are primarily affected by the Great Lakes (due to temperature rise and not by temperature extremes), while the built environment sector is directly affected by heat waves (very sensitive)

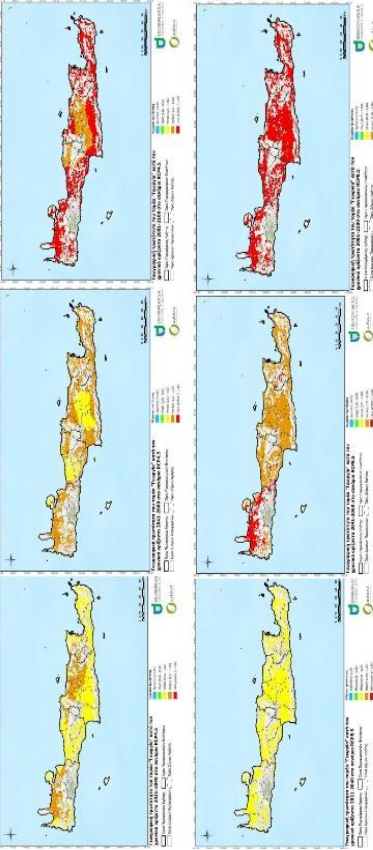
The climate indices selected and associated with climate impact drivers in Step 2, will be used to describe the degree of exposure of each grid point of the study area, to climate impact drivers, based on the following normalized scale:

- ✓ **Negligible exposure:** 0
- ✓ **Low exposure:** 1
- ✓ **Medium exposure:** 2
- ✓ **High exposure:** 3
- ✓ **Very high exposure:** 4

The approach for the correlation of each index change (i.e. change between the reference period and the short-term horizon in each RCP scenario) with the degree of exposure was presented in a matrix table. For example, a change in the near-surface air temperature (tas), compared to the reference period which is higher or equal to 4 °C, is considered to correspond to a very high degree of exposure, while a change between 1 and 2 °C, is considered to correspond to a medium degree of exposure.

 <p>15th International Scientific Conference on Energy and Climate Change Athens, 12-14 October 2022</p> <p>Vulnerability Assessment</p>	 <p>15th International Scientific Conference on Energy and Climate Change Athens, 12-14 October 2022</p> <p>The case of a vulnerable sector - Agriculture</p>
<p>Vulnerability comes up as the function of sensitivity (Step 3) and exposure (Step 4). Vulnerability = Sensitivity x Exposure</p> <p>Vulnerability is assessed for each climate impact driver separately, but in the end the degree of vulnerability is overall assessed using the following normalized scale (in terms of past climate):</p> <ul style="list-style-type: none"> ✓ Negligible vulnerability: < 0.25 ✓ Low vulnerability: 0.25 – 0.50 ✓ Medium vulnerability: 0.50 – 1.00 ✓ High vulnerability: 1.00 – 1.50 ✓ Very high vulnerability: > 1.50 <p>The vulnerability assessment was undertaken with two approaches:</p> <ul style="list-style-type: none"> • Geographic vulnerability: Investigates the geographic areas for each sector that are most vulnerable to climate change. In this case, vulnerability was calculated only for the grid points which belong to the sector under investigation. • Sectoral vulnerability: Investigates the sectors of the natural and anthropogenic environment that are most vulnerable to climate change and identifies grid points and sectors that are most vulnerable. In this case, the sectoral vulnerability is the average vulnerability value of the grid points that correspond to geographic areas of the sector. 	 
 <p>15th International Scientific Conference on Energy and Climate Change Athens, 12-14 October 2022</p> <p>Key impacts of climate change</p>	 <p>15th International Scientific Conference on Energy and Climate Change Athens, 12-14 October 2022</p> <p>Key impacts of climate change</p>
<ul style="list-style-type: none"> <input type="checkbox"/> Reduction of available water reserves <input type="checkbox"/> Increased fire risk <input type="checkbox"/> Reduction in annual agricultural production, shift to less water-intensive crops <input type="checkbox"/> Reduction of soil fertility, aggravation of the phenomenon of desertification <input type="checkbox"/> Changes in the growth rate of flora species <input type="checkbox"/> Increased presence of pests & diseases <input type="checkbox"/> Increase in occurrence of flooding events <input type="checkbox"/> Increase in river/stream stereosupply, ecological disturbance of water bodies in estuaries <input type="checkbox"/> Increase in erosion phenomena <input type="checkbox"/> Increased risk of landslides <input type="checkbox"/> Changes in habitats & availability of food and water for animal species <input type="checkbox"/> Increase of eutrophication, growth of harmful algae 	<ul style="list-style-type: none"> <input type="checkbox"/> Migration of marine species, invasion of alien species <input type="checkbox"/> Reduction in fishing production <input type="checkbox"/> Impacts on systems and methods of aquaculture activity <input type="checkbox"/> Causing partial or total disasters in sensitive historical monuments / archaeological sites (directly exposed to environment & weather events) <input type="checkbox"/> Coastal erosion – coastal floods <input type="checkbox"/> Entry of salt water into habitats, transitional waters & river estuaries <input type="checkbox"/> Increase in citizens' discomfort <input type="checkbox"/> Increased incidence of diseases (asthma, allergies, cardiorespiratory problems, etc.) <input type="checkbox"/> Increase in demand / energy consumption for air conditioning in the summer months <input type="checkbox"/> Erosions of road slopes, subsidence of pavements 

15th International Scientific Conference on Energy and Climate Change
Athens, 12-14 October 2022

Measures assessment and prioritization

The proposed measures were assessed and prioritized based on the following criteria:

- **Effectiveness** (Avoidance of impacts, reduction of intensity, restoration)
- **Implementation bodies**
- **Funding sources**
- **Priority based on vulnerability** (1st priority, 2nd priority)
- **Implementation period** (maturity or assignment time and implementation horizon)
- **Indicative budget**
- **Benefit** (financial, environmental, social) (high, moderate, low)
- **Cost / Effectiveness Ratio** (low, medium, high)



15th International Scientific Conference on Energy and Climate Change
Athens, 12-14 October 2022

Monitoring of the Plan

In order to effectively monitor the implementation progress of the Plan, an appropriate monitoring mechanism has been proposed. It will be coordinated by the Climate Change Department of the Region of Crete.

Relies on two key tools:

➤ **Data Collection Network (Observatory of Climate Change)**

➤ **Monitoring Indices**

- ✓ Monitoring of Climate Change Indices
- ✓ Indices of the Implementation of Measures
- ✓ Indices for the Evaluation of the Results from the Implementation of Measures

In addition to the creation of a Department of Climate Change, in order to achieve the desired results of the measures undertaken in the context of the implementation of the Plan, the establishment of a **Regional Committee for Combating Climate Change (PEAKA)** was proposed and will be implemented.



15th International Scientific Conference on Energy and Climate Change
Athens, 12-14 October 2022

Measures implementation cost

Sector	Per sector		Per measure type	
	Measures	Implementation Cost (per Sector)	Measures	Implementation Cost (per Measure Type)
INDUSTRIAL MEASURES	6	20,300,000.00	6	6,936
AGRICULTURE	28	43,200,000.00	27	5,000
LIVESTOCK	8	10,800,000.00	69	28,700,000.00
FORESTS	11	8,100,000.00	14	10,570,000.00
RECREATED AREAS	9	2,250,000.00	48	179,790,000.00
BIODIVERSITY – ECOSYSTEMS	16	3,850,000.00	5	17,500,000.00
FISHERIES	12	3,870,000.00	7	2,580,000.00
ADAPTATION	8	1,365,000.00	17	31,600,000.00
WATER RESOURCES (AVAILABILITY)	17	35,250,000.00	17	32,300,000.00
RIVERS (FLOOD EVENTS)	14	46,500,000.00	8	12,000,000.00
COASTAL ZONES	10	23,800,000.00	227	263,790,000.00
TOURISM	11	6,700,000.00	20	1,330,000.00
ENERGY DEMAND	5	25,400,000.00	17	32,300,000.00
ENERGY INFRASTRUCTURE	4	11,675,000.00	8	12,000,000.00
TRANSPORT INFRASTRUCTURE	19	29,700,000.00	8	12,000,000.00
HEALTH	16	6,800,000.00	8	12,000,000.00
BUILT ENVIRONMENT	70	17,750,000.00	8	12,000,000.00
CULTURAL HERITAGE	9	3,700,000.00	8	12,000,000.00
TOTAL	227	292,790,000.00	227	263,790,000.00



15th International Scientific Conference on Energy and Climate Change
Athens, 12-14 October 2022

Thank you for your attention!



Follow up:

a.sakalis@enviroplan.gr

www.enviroplan.gr

+30 2106105127



Reducing the life cycle impact of an office building by improving systems control. A case study.

Violeta MOTUZIENĖ,

Professor, Vilnius Gediminas technical university

Vilūnė LAPINSKIENĖ,¹

Assoc.prof. , Vilnius Gediminas technical university

Genrika RYNKUN,

Lecturer, Vilnius Gediminas technical university

Vydmantas DRAGŪNAS,

Student, Vilnius Gediminas technical university

¹ *Contact details of corresponding author*

Tel: +37065519119

e-mail: vilune.lapinskiene@vilniustech.lt

Address: Saulėtekio al. 11, LT-10223 Vilnius, Lithuania

Abstract

Today construction represents 39 % of global greenhouse gas emissions, of which 28 % are caused by the operational emissions and 11 % are related to materials and construction. Moreover, the embodied carbon in energy efficient buildings could give up to 80 % of life cycle GHG emissions. But practice shows that buildings, which are designed and built as energy-efficient, in reality not always show superb results. A common problem in existing office buildings is the level of systems' automation, which is often too low and/or management strategies are inefficient. The aim of this study is to perform the long-term monitoring of the indoor climate conditions in the existing office building, analyse the results and evaluate the operational energy-saving potential by increasing the efficiency of systems' management.

Monitoring has shown that during heating season the indoor air temperature is higher than the design temperature and no reduction for unoccupied periods is applied. Also, the amount of the air supplied was without regard to the occupancy of the premises, thus causing over-ventilation. Thus, potential for energy savings by applying alternative systems' control strategies was analysed and assessed based on BACS (Building Automation and Control System) methodology which complies with the standard EN 15232-1:2017. Here changing the control system strategies of the existing automation system from class C to B leads to operational heating energy savings of 20 % resulting 235 tons of CO₂ (approx. 0.1 t CO₂/m²) reduction during the 50 years life cycle of the building.

Keywords: building automation systems, life cycle analysis, indoor climate, monitoring, management.

1. Introduction

Today construction represents 39 % of global Greenhouse Gas emissions (GHG), of which 28% are caused by the operational emissions and 11% are related to materials and construction. Moreover, the embodied carbon in energy efficient buildings could give up to 80 % of life cycle GHG emissions (Kiamili et al., 2020). This means, that the construction industry has a significant role to play in achieving global

sustainability goals with the Paris climate agreement (United Nations, 2015; Chen at al., 2022; Amirhosain Sharif & Hammad, 2018 and European Green Deal: net zero emissions by 2050).

The situation by the Russia invasion to Ukraine has also reinforced the importance of energy dependence. The European Commission presented REPowerEU plan for ending the EU's

dependence on Russian fossil fuels and tackling the climate crisis.

The construction industry is also one of the sectors where it is important to implement strategies of the circular economy: stimulate the use of sustainable materials, promote material recovery, keep away from waste disposal to landfill (Norouzi et al., 2021) (Ghisellini et al., 2018). World Green Building Council's report "Bringing Embodied Carbon Upfront" (World Green Building Council's report), also defines the insight of zero operational and embodied carbon for new buildings by 2050 and highlights the importance of wider application of the Life Cycle Assessment (LCA) as a reconcilable, worldwide accepted method to evaluate and report environmental impact through the lifecycle of the building, presented in European standard EN 15978 (Kiamili et al., 2020). However, literature review shows (Gärtner et al., 2020; Kiamili et al., 2020; Verhelst et al., 2017) that most LCA studies focus on the improvements of building envelope and tend to minimize the boundaries of the system, leaving HVAC (Heating, Ventilation, and Air Conditioning) systems aside, despite that these systems are responsible for the main part of the energy consumed in the building during its long life cycle. The reason for that could be that HVAC systems are multiplex, made from various materials, it is complicated to quantify their relatively small mass of the materials from the project materials and it is very time consuming process. But even using Building Information Modelling (BIM), HVAC systems are abandoned. Furthermore, HVAC systems are great energy consumers in buildings (Verhelst et al., 2017), and as it was underlined by (Franco et al., 2021), they are related to the considerable energy performance gaps if compared to best practice ones. One of the reasons for worse building energy performance than predicted during the design stage is not efficient control of the HVAC systems. Meanwhile, it is emphasized in the literature, that building control systems play a vital role and can be assigned as an important element of the whole technical system in buildings (Gholamzadehmir et al., 2020; Jiang et al., 2018; Shi & Chen, 2021). Modern building control systems can save up to 25 % of energy, while the integration of systems together can increase energy savings of 8-18% over basic HVAC and lighting systems' energy

consumption (Building Automation System Market, 2022).

In summarizing it can be concluded that the potential for energy efficiency in buildings is still unexploited as in practice buildings often perform worse than designed. Especially this problem could be noticed in public buildings, such as offices, schools, universities, etc. (Carbonbuzz) (Liang et al. 2019; Zou et al. 2020). A common problem for such buildings is the level of system automation, which is too low, also as the system management which seems to be inefficient. The control systems and management aspects are purely analysed in terms of environmental impact during the life cycle of the building.

The aim of this study is to perform the long-term monitoring of the indoor climate conditions in the existing office building, analysed the results and evaluate the operational energy-saving potential by increasing the efficiency of systems' management. The life cycle approach is applied to assess the environmental impact of the proposed improvements during the assumed life cycle of the building.

2. Methodology

To assess if buildings' indoor climate systems management is efficient, and to identify possibilities for energy efficiency and environmental impact improvement, the methodology of the paper can be divided into the following steps: 1) long term monitoring of the indoor climate parameters and open-office occupancy; 2) measurement data processing and analysis; 3) assessment of alternative automatization and/or management strategies to improve energy efficiency, based on BACS methodology; 4) assessment of decrease of the environmental impacts in terms of CO₂ emissions during the life cycle of the building. Life cycle analysis is based on operational energy for heating, assuming the life cycle of the building – 50 years.

The monitoring process is a core of this study and therefore monitored building and monitoring process is described in details at subsections 2.1 and 2.2. Data processing was performed using Excel, mainly paying attention to the indoor environment during the occupied hours. The analysis enabled to identify: if the problems with indoor comfort exist and if the

HVAC systems work efficiently, if there exists energy saving potential which can be reached with simple improvement in systems control. The potential savings were also assessed in simplified BACS methodology. Just potential energy savings for heating were finally assessed as for the other systems it was not possible to identify actual energy consumption.

The BACS methodology provides an estimate of the energy savings that would be obtained by changing the class of the control system. The analyzed building matches the management class C, as the proposed management changes would make the building management class B.

In order to estimate how much energy will be saved by installing Building automation and control system (BACS) and Building technical management (BTM) systems of a higher energy efficiency class, a preliminary assessment can be performed according to the standard EN 15232-1:2017. For this, it is necessary to know how much energy a building with standard automation will consume per year and apply the following formula:

$$Savings = 100 \cdot E_{BACS_C} \cdot (1 - f_{BACS_B}), \% \quad (1)$$

Here:

E_{BACS_C} – annual energy consumption for class C (existing building), kWh;

f_{BACS_B} – the BACS efficiency indicator of the planned class, which is found in the methodology tables, that for thermal energy is 0,8.

In this case the savings for heating would draw up 20 % - energy consumption would decrease from 44,5 kWh/m², to 34,48 kWh/m². Analogously, electricity savings can be preliminarily determined. As the coefficient f_{BACS_B} is 0,93, this could be an additional electricity energy saving of 7%. Additional investment payback times could be estimated using manufacturer-specific calculation tools, for example EPC-Tool. Finally, to demonstrate that small and simple improvements in buildings may have significant environmental effect during the life cycle of the building, LCA was performed. It was assumed, that:

- No additional embodied energy and related emissions are needed to implement better control of HVAC systems or that this embodied part is insignificant.

- The highest impact is made during the operational phase and therefore just this stage is assessed.
- Life cycle of the building is 50 years.
- As the building is heated by natural gas, CO₂ emission factor was assumed based on national norms – 0.22 kg CO₂/kWh (STR 2.01.02:2016).

The useful area of the building is 2405 m².

2.1. Case study building

The investigated administrative building (Figure 1), where monitoring is carried out, is located in Vilnius city and according to the energy efficiency certificate belongs to class B. The heat consumption declared in the certificate is 43.1 kWh/m². The actual normalized (recalculated according to design indoor and outdoor conditions) heat consumption of the building according to 2019 data was 44.5 kWh/m². Thus, the energy efficiency gap in this case is not significant, but there are uncertainties related to the assumptions made during the certification regarding the indoor air temperature, since the systems were designed to maintain an indoor air temperature of 22°C, and the certification requires an assumption of 20°C. Thus, the gap assuming a temperature of 20°C during normalization would be larger - 59 kWh/m² (32%).

A representative room in the building is chosen for observation - an open office on the second floor (Figure 2). In a cabinet with 15 workplaces, one workplace has 8.24 m² of room area. However, only 13-14 workplaces are continuously used - there are more of them than employees. The room was monitored from 06.01.2021 to 27.11.2021, a total of 325 days. The purpose of the monitoring is to determine the main parameters of the microclimate and the prevailing air quality in the premises. During the research work, the following are measured: temperature, CO₂ concentration, air movement speed, relative humidity, total concentration of volatile organic compounds.

Also, one of the goals of the measurement is to create accurate schedules of people's presence in the premises. For that purpose, presence position sensors are installed in each workplace, which calculate how much time a person spends at their workplace and how many people are in the room during the analysed period.

The sensor's laser detects movement, and the temperature sensor confirms that an employee is sitting at the current workplace. The sensor captures the activity in the workplace and provides a graph of the occupation of the workplace. The received data is processed and presented at an interval of 1 hour. Analysing the graphs of indoor microclimate parameters, indoor occupancy and air quality, insights and suggestions are provided for more efficient indoor management. The arrangement plan of the sensors is shown in Figure 2, and it also shows the location of the microclimate measurement station in different measurement periods. The station collected data at a height of 1.2 m of the working area of a sitting person. The specifications of the measurement equipment used are given in Table 1.

3. Results

3.1. Monitoring

Room temperature measurements. The temperature in the representative room was measured from 06/01/2021 to 27/11/2021, using weather station HOBO MX1102A, this

period included also quarantine caused by COVID-19. The temperature variation is presented in Figure 3, where red lines represent the limit of the design temperatures during the heating and the summer season (22°C for the heating season, and 24°C for the cooling season). Figure 3 shows, that overheating is a problem in winter, as the temperature most of the time is higher than the design temperature and was never lower than 19.4°C. It is obvious that the potential for energy saving during the heating season through better system control and management is unexploited. For the cooling season interpretation for this graph would be not correct, as air conditioning system is working just during the occupied hours. As it is important to ensure comfortable indoor temperatures just during the occupied hours, therefore data were additionally filtered excluding unoccupied hours.

Figure 4 presents a typical working day during the heating season to demonstrate temperature variation in relation to the occupancy (black curve) of the room.



Figure 1: The object of the study.

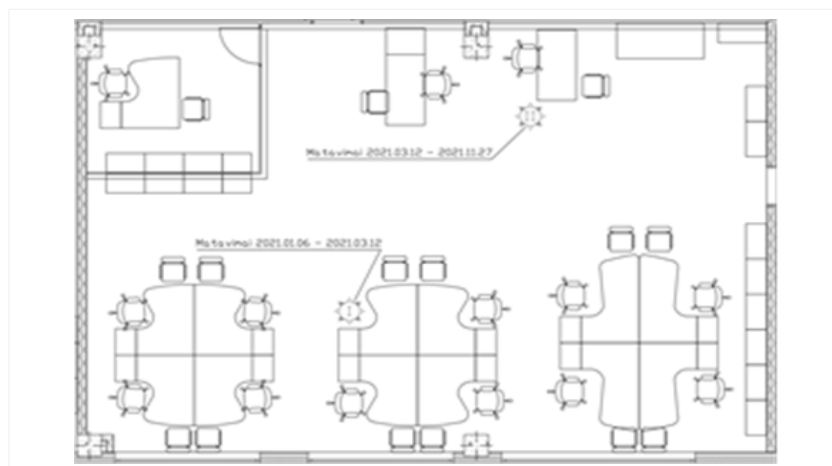

Figure 2: Monitored building and sensors location in the room.

Table 1: The monitoring equipment of indoor climate and air quality.

The device	Purpose	Characteristics
Data Logger -Almemo 2960-8A	Collection of air velocity data	Scanning data up to 50 times per second; <ul style="list-style-type: none"> • Working environment: -20° C to +70° C, 95% RH; • Accuracy ± 2.5%.
TableAir sensor	Scheduling the workplace	Motion sensor (PIR) <ul style="list-style-type: none"> • Heat sensor • Data transfer 4.0LE • WiFi 2.4 Ghz
Air motion sensor - ALMEMO FV A605 TAI/TA50	Recording air velocity	<ul style="list-style-type: none"> • Measuring range 0.1 - 1.0 m / s; • Error ± 1.0%; • Operating environment from 0° C to +40° C, 0-90% RH.
Sensor for Volatile Organic Compounds Concentration - AERASGARD RLQ-W	Determination of total volatile organic compound concentration	<ul style="list-style-type: none"> • Measures 26 pollutants; • Operating environment from 0° C to +50° C.
Data logger - COMET U6841	Data collection of total volatile compounds	<ul style="list-style-type: none"> • Data collection in the range from 1s to 24h; • Operating environment from -20° C to +60° C.
Weather station: HOBO MX1102A	Recording and storage of air temperature, relative humidity and CO ₂ concentration	<u>Air temperature:</u> <ul style="list-style-type: none"> • Measuring range from 0° C to +50° C; • Error ± 0.21° C; <u>Relative humidity:</u> <ul style="list-style-type: none"> • Measuring range from 1 to +90%; • Error ± 2%; <u>CO₂ concentration:</u> <ul style="list-style-type: none"> • Measurement range from 0 to 5000 ppm; • Error ± 50 ppm;

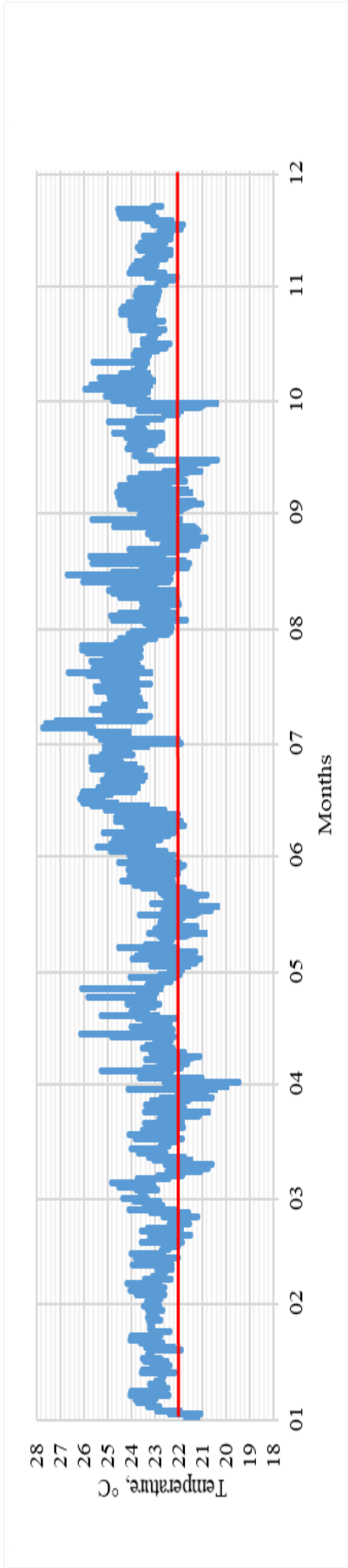

Figure 3: Hourly temperature variation of a representative room for the measured period (all hours included).

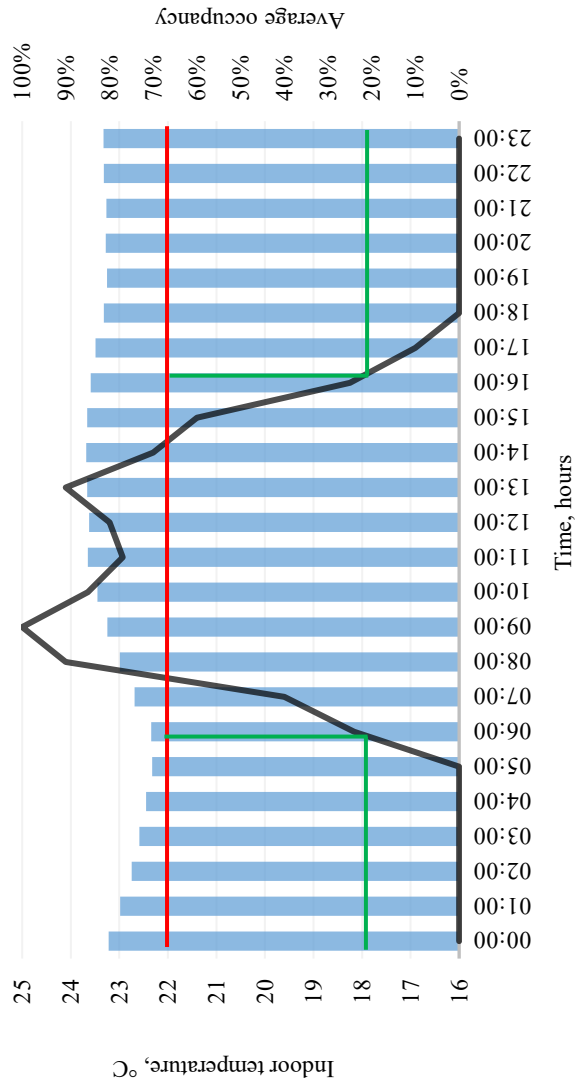

Figure 4: Typical office day temperature variation during the heating season.

The occupancy is an average measured during the whole period and it can be seen that it is very low – a maximum of 25%. The employees start to occupy the room at 6:00 a.m. and leave their office till 6:00 p.m. Obvious that overheating is a problem not just during the occupied hours, but also during non-occupied. Therefore, energy savings for heating can be reached without much effort by lowering the temperature up to 22°C and also applying intermittent heating during unoccupied hours at least up to 18°C (green line), which is still an acceptable temperature if the occupancy happens.

Figure 5 presents an analysis of the temperature frequencies just for occupied hours separately for the heating season and non-heating season. It can be seen that during the heating season temperature is equal or higher than design temperature almost all the time and that is 1537 hours. Non-heating season includes all the rest of the measured period, and here we can see that overheating (more than 24°C) also happens quite often but most of the time it is in acceptable range, as 26°C is still suitable indoor temperature in summer. So the non-heating season with the non-conditioned periods in spring and autumn gives relatively good temperature maintenance results. Therefore, heating system operation optimization must be a priority in this building.

Humidity measurements. Relative humidity was measured for the same period as the other indoor climate parameters. Fig. 6 demonstrates the variation of the relative humidity for all the periods not excluding occupied hours. Red lines mark the minimum and maximum acceptable humidity values (min. 35 % for summer, max. 60

and 65 % accordingly for winter and summer). It can be noticed, that for the heating season most of the time air is too dry and for the rest of the year is mostly in an acceptable range. One of the reasons for dry air is also related to overheating issues discussed above. More detailed analysis is further presented just for the heating season as this is the problematic period in terms of temperatures and relative humidity.

From Figure 7, where just a typical working day of the heating season is presented together with the average office occupancy, it is seen that the humidity is lower for the occupied hours and low occupancy makes no noticeable influence on humidity. The humidity of the occupied hours drops as the temperature rises (Figure 4). Overheating is not just energy waste, but also causes low relative humidity.

Figure 8 demonstrates for how many occupied hours, within the measured period, humidity is out of range. The indoor air is too dry for more than half of the year (as it was seen in Figure 6, this is mainly the heating season) or 1594 working hours (Figure 8) for the measured period.

Air quality and air velocity measurements. The building has a mechanical balanced air ventilation system with heat recovery; therefore it is expected that air quality must be sufficient. In performed measurements air quality was assessed in terms of Volatile Organic Compounds (VOC) Concentration and CO₂ concentration. The Source of VOC pollution is the building itself with its materials, furniture, and equipment. The sensor which was used in the room can detect 26 organic pollutants in the air.

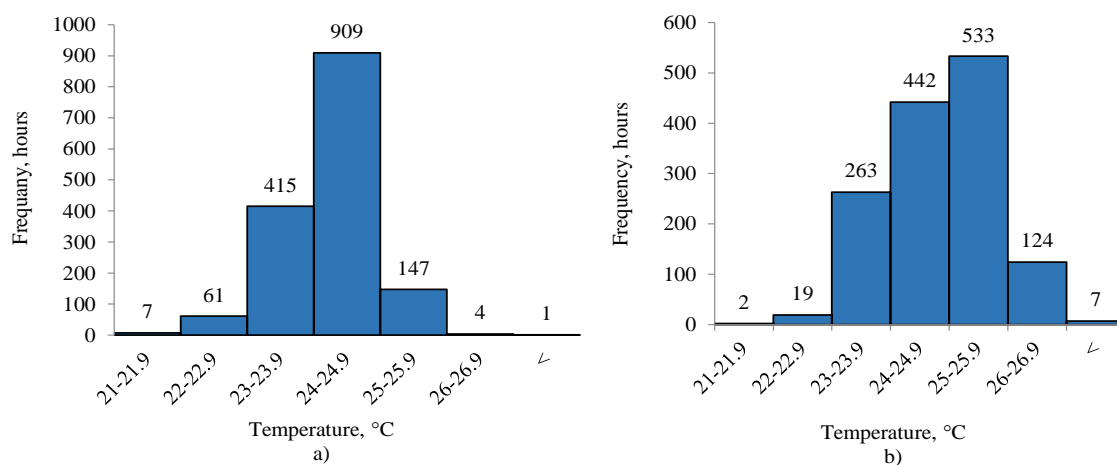

Figure 5: Room temperature frequencies for occupied hours: a) heating season; b) non-heating season.

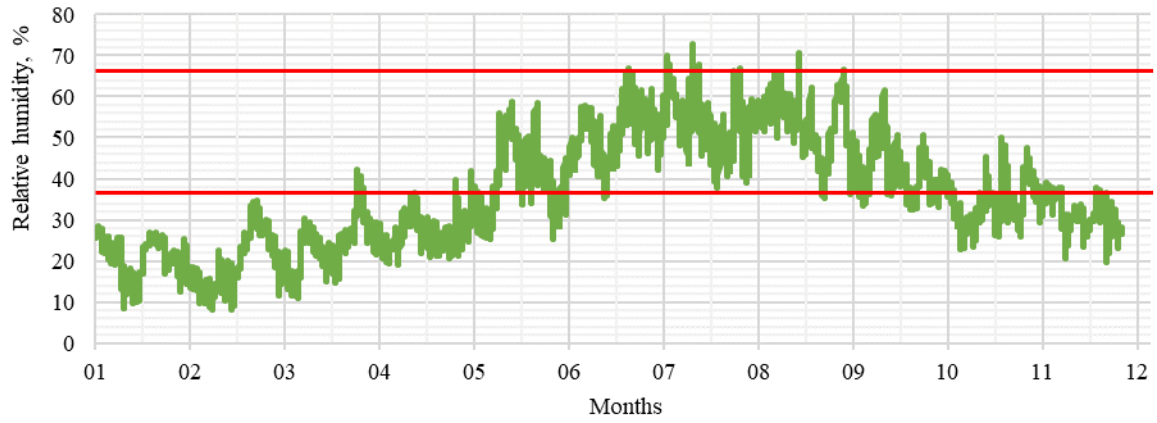

Figure 6: Hourly relative humidity variation of a representative room for the period (all hours included).

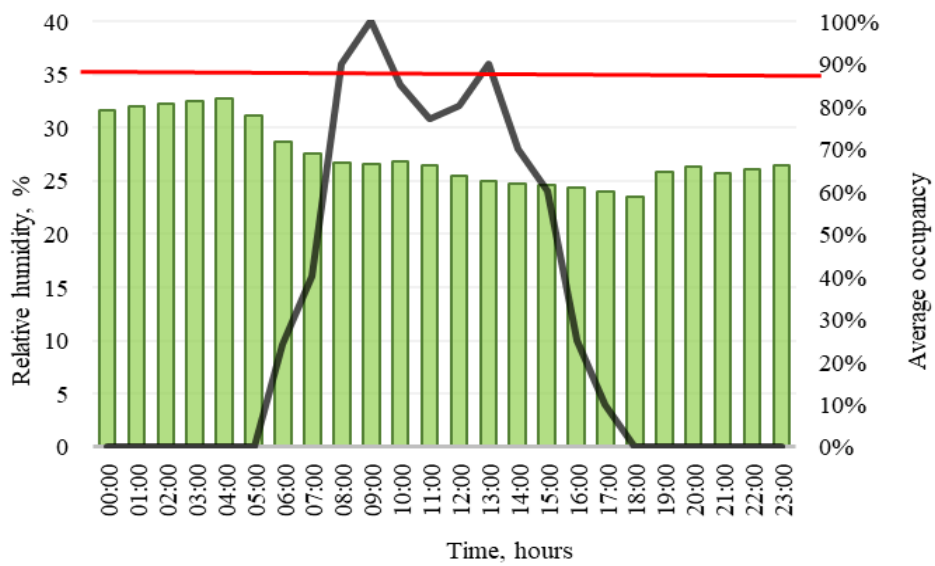

Figure 7: Typical office day temperature variation during the heating season.

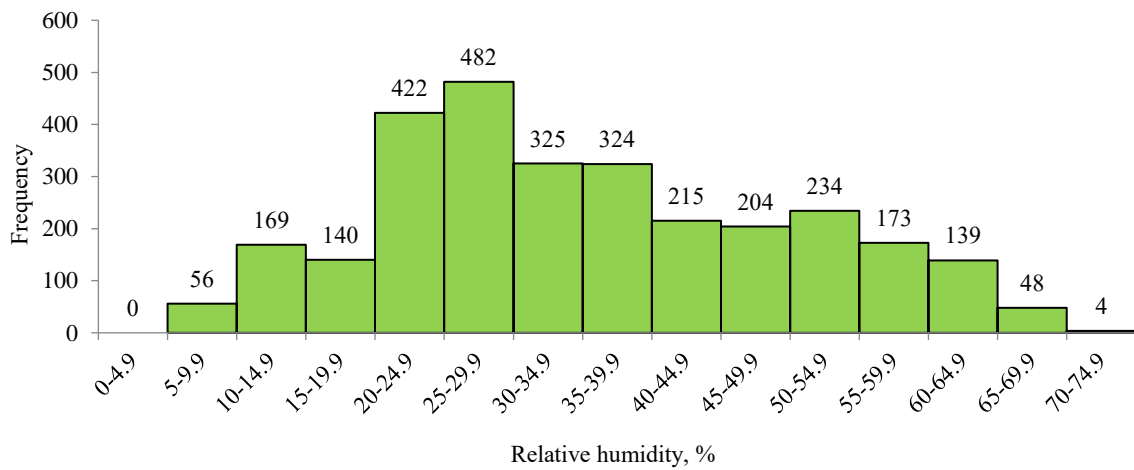

Figure 8: Room relative humidity frequencies for occupied hours.

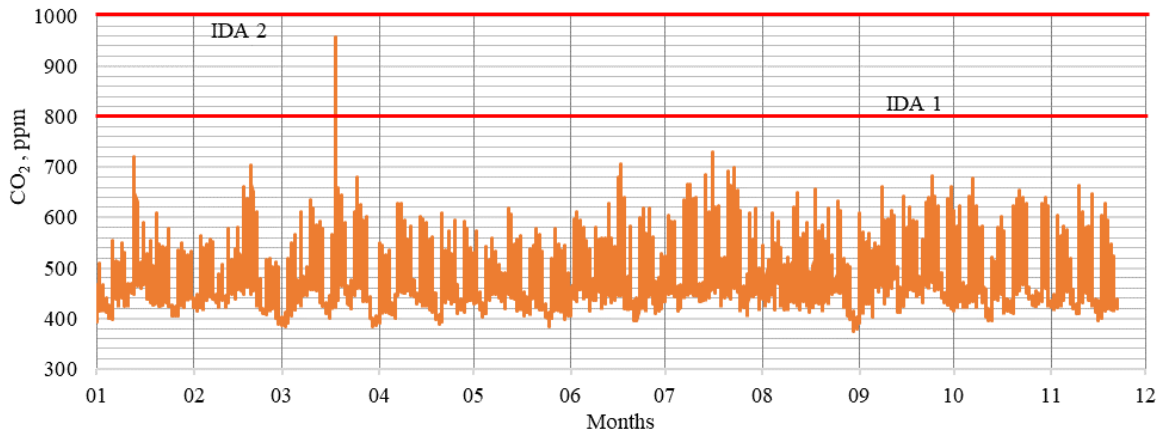

Figure 9: Hourly CO₂ concentration variation of a representative room for the period (all hours included).

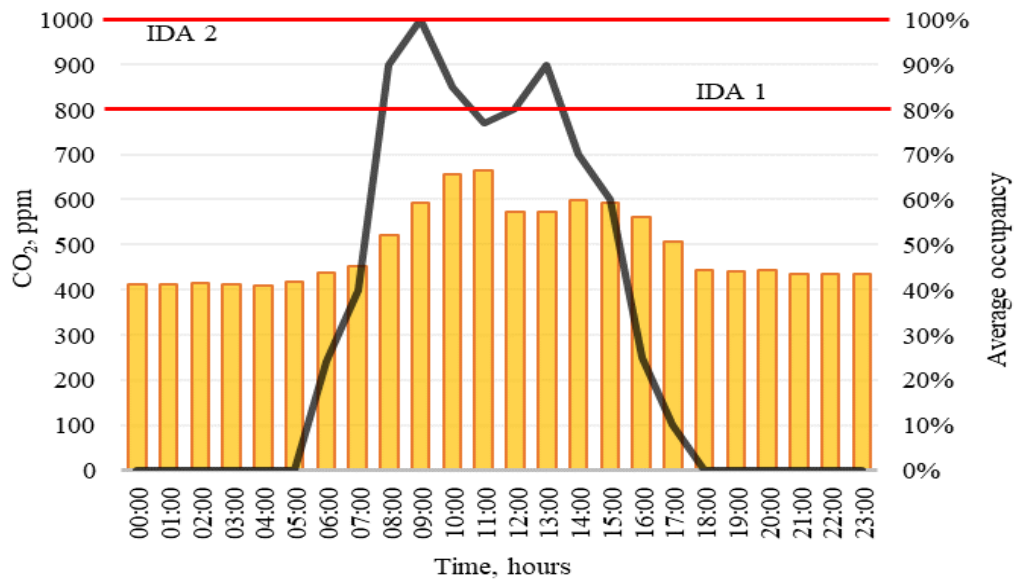

Figure 10: Typical office day CO₂ concentration variation during the heating season.

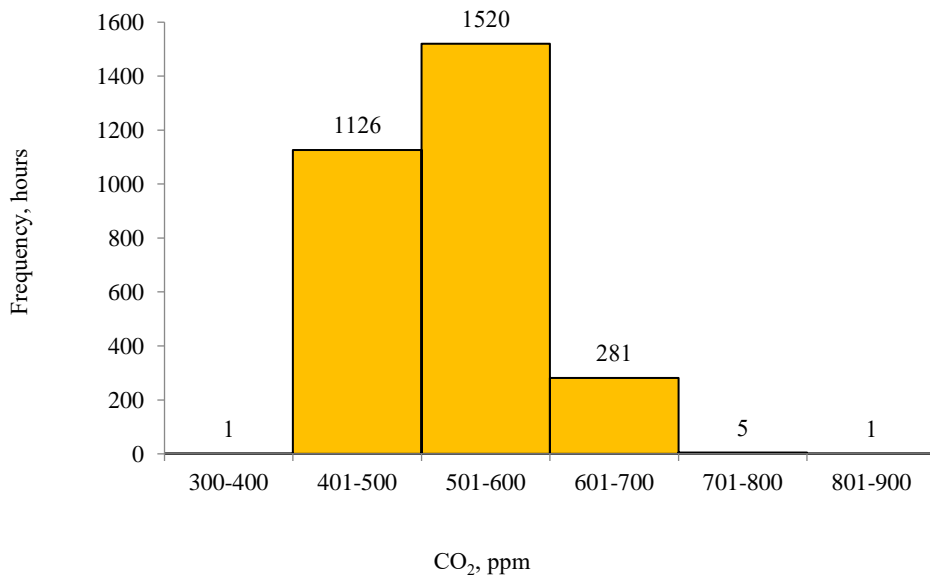

Figure 11: Room CO₂ concentration frequencies for occupied hours.

Based on the total concentration of volatile compounds, a room air quality index ranging from 4 to 20mA is derived. The methodology provided by the manufacturer was used to assess air quality. The concentration of VOC in the office ranged from 4 to 6mA, the maximum fixed value was 8.87mA, and the prevailing average in the premise was 4.88 mA. From this data it can be assumed, that the indoor air quality was appropriate, as the measured concentration of organic pollutants is quite low and does not exceed the maximum permissible value of 10.4 mA, so does not need further discussion. Meanwhile, CO₂ pollution is related to the occupancy of the building. Figure 9 presents variation of CO₂ concentration in the room during the whole measured period. Red lines mark the limits of the levels of indoor air quality – IDA 1 (high, when CO₂ concentration is less than 400 ppm above the outdoor air concentration) and IDA 2 (average, when CO₂ concentration is 400-600 ppm above the outdoor air concentration). It is assumed that outdoor air CO₂ concentration is 400 ppm, accordingly IDA 1 corresponds to up to 800 ppm and IDA 2 – up to 1000 ppm. It is seen that air quality in the building nearly all the time IDA 1 quality and much better. Thus, meaning that building is over ventilated and energy is not saved and average concentration during the occupied hours is 520 ppm.

Figure 10 shows the CO₂ concentration and the average occupancy schedule during the day. The CO₂ concentration starts to increase from 6.00 am when the first employee comes into the room and raises until 11:00 a.m. when it reaches its peak. A lunch break begins at 11:00 a.m. when some employees leave the premises and CO₂ concentrations fall. Starting from 2:00 p.m., employees are returning to their workplaces and the carbon dioxide concentration is rising again. However, from 3:00 p.m. the concentration starts to decrease (due to the declining number of employees) and at 6:00 p.m. reaches 440 ppm., almost outdoor air. Figure 11 just proves, that space is over-ventilated during the whole measured period even when estimating just working hours. All these figures show, that CO₂ concentration during the measured period was far to reach the maximum value and allows to conclude, that the ventilation air flow rates could be decreased significantly exploiting the potential for energy savings. The most efficient would be ventilation

system control according to the number of occupancy – the variable air volume system, but it would need interventions into existing system and significant investments. Real measured occupancies and concentrations may help without additional investments to rebalance the system to correspond better to realistic, much lower demands of air.

Measured air velocities maximum values were equal to 0.14 m/s and didn't exceed acceptable values even when the meter was positioned 1 m from the air supply diffuser, therefore it is not further discussed.

3.2. Energy saving potential

As described in the methodology above, monitoring results' analysis enables to assess the indoor comfort and energy saving potential opportunities in the building. It was found that the indoor temperature in the building, mainly during the heating season, is controlled very inefficiently. Overheating also causes extremely low relative air humidity in the room. The other energy saving potential was found in over-ventilation of the room, where air flow rates can be significantly decreased and adapted to the real (much lower than design) occupancies.

More efficient Building Automation and Control Systems (BACS) for HVAC systems would be beneficial to increase the energy efficiency of the building. BACS refers to the products that monitor and automatically adjust the energy using technologies to deliver a comfortable environment while optimising energy use. Based on EN 15232-1:2017, analysed building is identified to be of C energy performance class, which is considered as standard. Improving BACS to class B would enable the control of separate zones (in our case indoor temperatures and air flow rates) of the building, better monitoring of energy flows and their management. More information on exact measures can be found in (Siemens, 2018). Economic evaluation with the required investments and payback times can be estimated e.g. with EPC-Tool available from Siemens.

The potential savings from higher BACS energy performance class were assessed based on above (in Methodology section) described simplified methodology. It was calculated that just annual heating energy savings would be 20%, e.g. from 44.5 kWh/m² they would decrease to 34.48 kWh/m².

In the absence of separate electricity metering for ventilation and cooling equipment in the building, the actual consumption of these systems and potential savings cannot be determined, but according to the methodology, they can be predicted as 7 %. Finally, based on the assumptions described in Methodology section, it was estimated that just because of operational heating energy savings, within the assumed 50 years life cycle of the building 235 tons of CO₂ (approx. 0.1 t CO₂/m²) will be avoided. As it was already mentioned, additional savings on ventilation and air-conditioning system electricity will also give additional benefits, but they cannot be estimated for this building.

3. Conclusions

Analysed building is of B energy performance class. The difference between actual and design energy consumption for heating (so called Energy Performance Gap) in this building is 32 % (adjusted at 20°C indoor temperature) and this can be considered a relatively small Gap compared to e.g. buildings presented in CarbonBuzz database. However, the measurements of the open-type office premises show that the control of the premises' HVAC systems is not efficient enough and the core problems are:

1. The premise is overheated during the heating season both during working and non-working hours nearly all of the time. The overheating also causes extremely low relative humidity during the heating season.
2. The energy saving potential of intermittent heating for unoccupied hours is not exploited.
3. The occupancy in the premise is much lower than design – maximum daily occupancy is

on average just 25%. Therefore, the premise is strongly over-ventilated as system does not react to the number of occupants and performs at the design air flow rates.

Identified problems obviously show the demand for better HVAC systems control and management. Thus, the potential for energy savings by applying alternative systems' control strategies was analysed and assessed based on BACS (Building Automation and Control System) methodology which complies with the standard EN 15232-1:2017. Here changing the control system strategies of the existing automation system from class C to B leads to operational heating energy savings of 20 % resulting 235 tons of CO₂ (approx. 0.1 t CO₂/m²) reduction during the 50 years life cycle of the building. The additional benefits for ventilation and air-conditioning could not be assessed for the building, as these systems have no separate electricity meters.

A more precise estimation also including electricity savings could be performed by applying dynamic energy simulation. This is planned for future research.

The study demonstrated once more that there is still significant unexploited energy saving potential in existing buildings. Some of the savings can be reached even with no investments, just analysing monitoring data and adjusting systems working schedules without losing comfort for occupants. The problem of existing (new) buildings' energy performance gap and saving potential related to building control, automation and management is still underestimated. Now, when world is facing the energy crisis, identifying, reviewing, evaluating, improving energy performance of existing buildings must become one of top priorities.

Acknowledgment

This research was funded by a grant (No. S-MIP-20–62) from the Research Council of Lithuania (LMTLT). The authors also would like to express their gratitude to JSC Caverion Lietuva and TableAir UAB for their cooperation and help performing the measurements under extreme pandemic conditions.

References

Amirhosain Sharif S., & Hammad A., 2018. Simulation-Based Multi-Objective Optimization of institutional building renovation considering energy consumption, Life-Cycle Cost and Life-Cycle Assessment. <https://doi.org/10.1016/j.jobee.2018.11.006>

CarbonBuzz, RIBA CIBSE platform, 2022. Available at: <https://www.carbonbuzz.org/casestudiestab.jsp>

Chen W., Yang S., Zhang X., Jordan N. D. & Huang J., 2022. Embodied energy and carbon emissions of building materials in China. *Building and Environment*, 207, 108434. <https://doi.org/10.1016/J.BUILDENV.2021.108434>

Franco A., Misericocchi L. & Testi D., 2021. HVAC energy saving strategies for public buildings based on heat pumps and demand controlled ventilation. *Energies*, 14 (17). <https://doi.org/10.3390/en14175541>

Gärtner J. A., Massa Gray F., & Auer T., 2020. Assessment of the impact of HVAC system configuration and control zoning on thermal comfort and energy efficiency in flexible office spaces. *Energy and Buildings*, 212. <https://doi.org/10.1016/j.enbuild.2020.109785>

Gholamzadehmir M., del Pero C., Buffa S., Fedrizzi R. & Aste N., 2020. Adaptive-predictive control strategy for HVAC systems in smart buildings – A review. *Sustainable Cities and Society*, 63, 102480. <https://doi.org/10.1016/J.SCS.2020.102480>

Kiamili C., Hollberg A. & Habert G., 2020. Detailed assessment of embodied carbon of HVAC systems for a new office building based on BIM. *Sustainability (Switzerland)*, 12 (8). <https://doi.org/10.3390/SU12083372>

Market and Markets, 2022. Building Automation System Market Size & Share | Industry Report, 2022-2027 | MarketsandMarkets™. Online journal available at: <https://www.marketsandmarkets.com/Market-Reports/building-automation-control-systems-market-408.html>

Ministry of the Environment of the Republic of Lithuania, 2016. STR 2.01.02:2016 "Design and certification of energy efficiency of buildings". Vilnius. only in lithuanian language available at: <https://e-seimas.lrs.lt/portal/legalAct/lt/TAD/15767120a80711e68987e8320e9a5185/asr>

Norouzi M., Chàfer M., Cabeza L. F., Jiménez L. & Boer D., 2021. Circular economy in the building and construction sector: A scientific evolution analysis. *Journal of Building Engineering*, 44, 102704. <https://doi.org/10.1016/J.JOBE.2021.102704>

Siemens 2018. Building Automation – Impact on Energy Efficiency. Application of EN 15232-1:2017. Siemens Switzerland, 142 p. In September 2022, EN ISO 52120 (including some content additions and corrections) replaced the previous standard EN 15232-1:2017. Available at: <https://sid.siemens.com/v/u/A6V10258635>

European Commission, 2022. REPowerEU: A plan to rapidly reduce dependence on Russian fossil fuels and fast forward the green transition. Luxemburg. Available at: https://neighbourhood-enlargement.ec.europa.eu/news/repowerEU-plan-rapidly-reduce-dependence-russian-fossil-fuels-and-fast-forward-green-transition-2022-05-18_en and https://eur-lex.europa.eu/resource.html?uri=cellar:fc930f14-d7ae-11ec-a95f-01aa75ed71a1.0001.02/DOC_1&format=PDF

United Nations Framework Convention on Climate Change, 2015. Adoption of the Paris Agreement, 21st Conference of the Parties, Paris: United Nations. Available at: <https://unfccc.int/resource/docs/2015/cop21/eng/109r01.pdf>.

Verhelst J., van Ham G., Saelens D. & Helsen L., 2017. Model selection for continuous commissioning of HVAC-systems in office buildings: A review. *Renewable and Sustainable Energy Reviews*, 76, 673–686. <https://doi.org/10.1016/J.RSER.2017.01.119>

Liang J., QiuY., Hu M. Mind the energy performance gap: Evidence from green commercial buildings. *Resources, Conservation and Recycling* 2019:141:364–377 <https://doi.org/10.1016/j.resconrec.2018.10.021>

Zou P. X. W., Alam M. Closing the building energy performance gap through component level analysis and stakeholder collaborations. *Energy and Buildings* 2020:224:110276. <https://doi.org/10.1016/j.enbuild.2020.110276>

Geothermal resources and local development in Poland

Dr. Katarzyna A. KUREK ¹

Postdoctoral Researcher, Wageningen University and Research, The Netherlands

Prof. Wim HEIJMAN

Wageningen University and Research, The Netherlands

Czech University of Life Sciences, Czech Republic

Dr. Johan VAN OPHEM

Wageningen University and Research, The Netherlands

¹ *Contact details of corresponding author*

Tel: +31 646 117446

e-mail: katarzyna.kurek@wur.nl

Address: Wageningen University and Research, School of Social Sciences
Hollandseweg 1, 6706 KN Wageningen, The Netherlands

Abstract

Next to the heat and energy production, geothermal energy presents with opportunities for rural and suburban areas linking sustainable development goals with expansion of new local economy sectors. The aim of this research is to fill in the gap in the literature and establish an empirical link between the use of the geothermal renewable and measures of local development. This research attempts to provide a methodology that measures the induced impact related to the socioeconomic development. The theoretical conceptualization underpinning this study is reflected in endogenous growth theories as well as in regional economics approach. By using the MCDM methods a local development model was built to demonstrate the statistical relation between exploited geothermal energy and model parameters. We used various regression modelling as well as adopted shift-share analysis for the local economic structure. The versatility of this study lies in the fact that exercised on the Polish municipality cases our model is applicable for analysis to any geothermal location in the world. We produced studies, where the competitive advantage of using geothermal resources in the local economies is econometrically illustrated. A faster development of the geothermal municipalities comparing to the referred regions is observed. A novel application of methods used in regional sciences served to identify changes in the local economic structure, that the geothermal resources contribute to. The established links between the local development and utilization of the geothermal resources call upon a new research phenomenon, that initiates further discussion.

Keywords: geothermal resources, direct use, local development, Multiple-criteria decision-making (MCDM), regression modelling.

References

Kurek K. A., 2021. *Geothermal resources and local development in Poland* (Doctoral dissertation, Wageningen University and Research).

Geothermal Resources and Local Development in Poland

Katarzyna A. Kurek

15th International Scientific Conference on Energy and Climate, 12-14 Oct. 2022, Athens.



Geothermal exploitation is local



- Geothermal energy is a thermal energy of the Earth's crust and originates from the formation of the planet and radioactive decay of material. Water and/or steam carry the geothermal energy to the Earth's surface.
- Geothermal heat activities at the area of reservoir
- Maximal network transportation < 30 km
- Available 24/7, non intermittent resource
- Inexhaustible provider of electricity and heat
- Sustainable source of energy
- No impact on the landscape
- Deep geothermal and local heat pumps

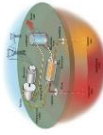

2

Lindal diagram

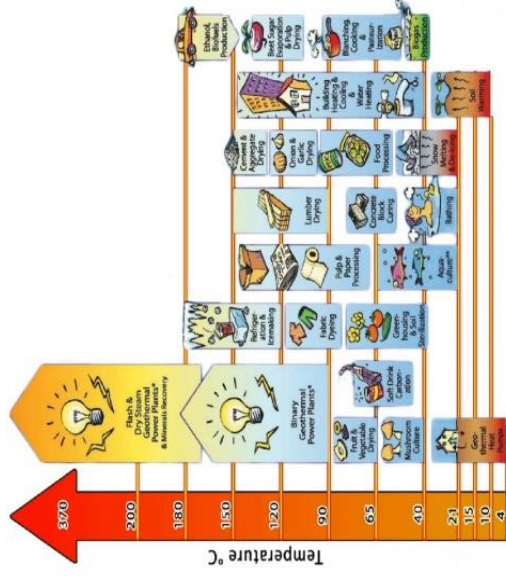

(Lindal, 1972)



3

PhD study

- Wageningen University, the Netherlands
- doi:10.18174/542196
- Researcher at CZU, Prague
- CEO of Time & Place Institute, Brussels

Geothermal resources and local development in Poland

Katarzyna A. Kurek



4

Problem definition

- Direct (heat/water), indirect (power) and induced (derived activities) effect of geothermal resources use (Rybach 2003).
- Induced impact: change in the socio-economic structure.
- Research gap about the geothermal impact on local development.
- Need of policy recommendations.



5

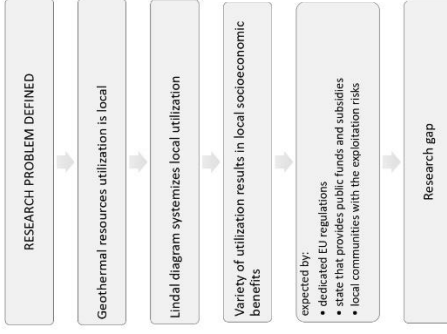

Research Question and Research subject

- Main RQ: What is the impact of the geothermal resources utilization on the development of the municipalities in which they occur?
- Approach:
 1. statistical observation of local socioeconomic indicators of the geothermal municipalities and their relation with the resource usage.
 2. comparative analysis of employment structure between the geothermal municipalities and regions where located.
- Study subject: local development conceptualized as a model of socioeconomic variables for the NUTS-5 level of analysis.
- **reproducible studies**



6

How a local development is measured?

- Single indicator e.g. GDP
- Theoretical approach: i) normative: institutional framework, e.g.: UN- HDI; ii) theoretical: imposed by an economic theory, e.g. utility measures
- Data driven approach: no of socioeconomic indicators constructs a single series
- Choice of multicriteria measures: 1) what it to be measured, 2) how complex is the problem
- Choice of a multicriteria measures in the development economics or regional economics:
 - Universal measures: assessing progress toward a common goal (e.g. poverty alleviation- HDI, GDP etc)
 - Measures towards unique goals of a community- own measure (this study)



7

Studies overview

- H: Introduction of a geothermal spa accelerates the socioeconomic development of the municipality in which it is established.
 - Geothermal recreational and spa centers accelerate the socioeconomic development of a municipality.
 - Municipalities with lower development index observe faster trend of development related to the establishment of geothermal centers.
- H: Exploitation of the geothermal resource has a positive impact on the competitiveness of a municipality.
 - Significant relationship between local socioeconomic indicators and geothermal parameters.
 - Geothermal GI production increase impacts 45% and geothermal bathing centers establishment 20% the increase of socioeconomic indicators growth of a municipality.
- H: Geothermal resources utilization leads to an increase of employment in the trade and service sectors at the municipality level.
 - Significantly higher employment is observed in the geothermal municipalities than in the reference regions.
 - Use of the geothermal resources in time notably changes local employment structure. Shift towards services and trades jobs, decreased traditional sectors employment (agriculture and heavy industry).



8

Theoretical background

- J. Schumpeter's legacy
- Endogenous growth theory
- Location theory
- Local development
- Cluster theory

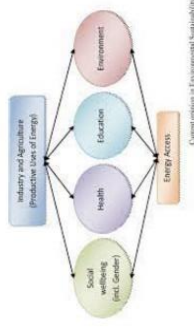

9

Community based approach

- Geothermal energy harnessed in local communities is assumed to influence the economic landscape of a region. The research problem is hence to conceptualize theoretical determinants of the geothermal resources development impact on local communities.
- Geothermal resources development theories research.
- Research Question: *what is the theoretical background for analysing the development of the geothermal resources?*
- Communities discourse in the geothermal literature and EU policies (CORDIS, Green Deal programme- Coal Region Transitions).
- Clean energy for islands programmes based in developments funds e.g. Madeira, Azores, Martinique, Galapagos.



11

Renewable Energy Communities legal background

- EU climate policies: Clean Energy Package, RED II, Electricity Directive.
- Concept emerged from actions of regionalising the energy transition.
- It acknowledges the development function of renewables beyond the energy provision.
- Generating energy locally means that profits and energy costs do not flow out of the region, and can help to bring down the cost of energy in the long run, whilst also inducing the emergence of local value chains. As installations are owned and operated at the regional level, new jobs are created both directly and indirectly.
- Geothermal: cases of regions, where the communities are owning/managing the resources. Identification of socioeconomic benefits of geothermal energy for local economies is an important element for the future resources development.

- Geothermal royalties system



10

Power for everyone concept

- Development concepts place the communities in the center of energy transition, democratization of energy.
- Jeremy Rifkin's work shifts attention to decentralization of energy production and related benefits. Geothermal energy production is included in Rifkin's pillars of Third Industrial Revolution. Future in geothermal technology.
- Following Elinor Ostrom analysis, geothermal resources are the commons (natural resources in climate change actions). Sustainable local use of geothermal resources, cascade uses, creation of socio-technological networks, community managed exploitation.
- Evolution of Julian Steward Cultural Ecology concept. It bases on local resources use and creates identification. Introduces ecological culture. Modern interpretations lay foundation for local energy clusters.



12

Some conclusions

- Further regulatory accents on the RES community and dedicated programs (including geothermal energy). Introducing regional incentives, tax write-offs, risk insurance, etc.
- Case studies of successful geothermal communities and socioeconomic benefits of going 100% geothermal.
- Recommendation to search for theoretical and practical hybrid solutions.
- Further regionalization of the use of geothermal energy and incentives for greater commercialization of resources (apart from heating). Fit for 55?



13

Thank you

katarzyna.kurek@wur.nl



14

On the possibility of a cyber-attack on optimizer-based photovoltaic generators

Sergei KOLESNIK

Student, Ben-Gurion University of the Negev, Israel

Alon KUPERMAN

Professor, Ben-Gurion University of the Negev, Israel

¹ *Contact details of corresponding author*

Tel: +97286461599

e-mail: alonk@bgu.ac.il

Address: 1, Ben-Gurion Blvd., POB. 653, Beer-Sheva 8410501, Israel

Abstract

Despite the fact that grid-connected photovoltaic (PV) systems have no moving parts, and therefore usually require low maintenance, they are still subject to various failures and faults. It is therefore required to create algorithms to facilitate the detection of possible faults occurring in PV systems as well as identify hazards imposed by malicious agents. Recent cyber-attacks on industrial power systems clearly point out the recent trend of digital battlefield. The potential damage caused by successful malicious act to such systems is much more severe than any other experienced by far. Among industrial power systems, photovoltaic based generation take a significant cut of renewable energy generated in the world. Malfunction of such a system may lead to harmful consequences from complete shutdown of a power plant unit to multiple casualties' disaster.

A paradigm shift of PV energy conversion methodology is currently taking place by shifting from large, centralized converters to small module-integrated decentralized converters, allowing to increase conversion efficiency, reduce hardware size and decrease return-of-investment time. However, it was found out by the authors that topologies used by module-level converters are based on replacing unidirectional passive semiconductors by bidirectional active semiconductors to increase efficiency for similar power density. In such systems, unidirectional power flow is assured by software means only, creating a cyber-attack opportunity in case the software is infected by malicious agents. The main goal of the research is therefore demonstrating that it is possible to reverse the power flow from a PV panel to power flow into a PV panel, imposing it to operate as a load rather than as a source by modifying only the software of interfacing power converters without altering the hardware, in order to impose physical damage such as fire to the PV panel.

Keywords: Photovoltaic generators, efficient DC-DC conversion, maximum power point tracking, real-time control, fire safety.

References

- Romero-Cadaval Enrique, Giovanni Spagnuolo, Leopoldo Garcia Franquelo, Carlos Andrés Ramos-Paja, Teuvo Suntio and Weidong Xiao, 2013. "Grid-Connected Photovoltaic Generation Plants: Components and Operation." IEEE Industrial Electronics Magazine 7 (2013): 6-20.
- Romero-Cadaval Enrique, François Bruno, Malinowski Mariusz, Zhong Qing-Chang, 2013. Grid-Connected Photovoltaic Generation Plants as Alternative Energy Sources. IEEE Industrial Electronics Magazine, 2015, 9, pp.18 – 32. Available at: https://www.researchgate.net/publication/329138751_Grid-Connected_Photovoltaic_Generation_Plants_as_Alternative_Energy_Sources.
- Alam M. K., Khan F., Johnson J. & Flicker J., 2015. A comprehensive review of catastrophic faults in PV arrays: types, detection, and mitigation techniques. IEEE Journal of Photovoltaics, 5(3), 982-997.
- Gadelovits Shlomo, Kuperman Alon, Sitbon Moshe, Aharon Ilan, Singer Sigmond, 2014. Interfacing renewable energy sources for maximum power transfer—Part I: Statics, Renewable and Sustainable Energy Reviews, Volume 31, 2014, Pages 501-508, ISSN 1364-0321, <https://doi.org/10.1016/j.rser.2013.12.039>.
- Kolesnik Sergei, Sitbon Moshe, Gadelovits Shlomo, Suntio Teuvo, Kuperman Alon, 2015. Interfacing renewable energy sources for maximum power transfer—Part II: Dynamics, Renewable and Sustainable Energy Reviews, Elsevier, vol. 51(C), pages 1771-1783.



On the possibility of a cyber-attack on optimizer-based photovoltaic generators

Sergei Kolesnik and Alon Kuperman

Applied Energy Laboratory
School of Electrical and Computer Engineering
Ben-Gurion University of the Negev
Israel



On the possibility of a cyber-attack on optimizer-based photovoltaic generators



Typical Photovoltaic (PV) system

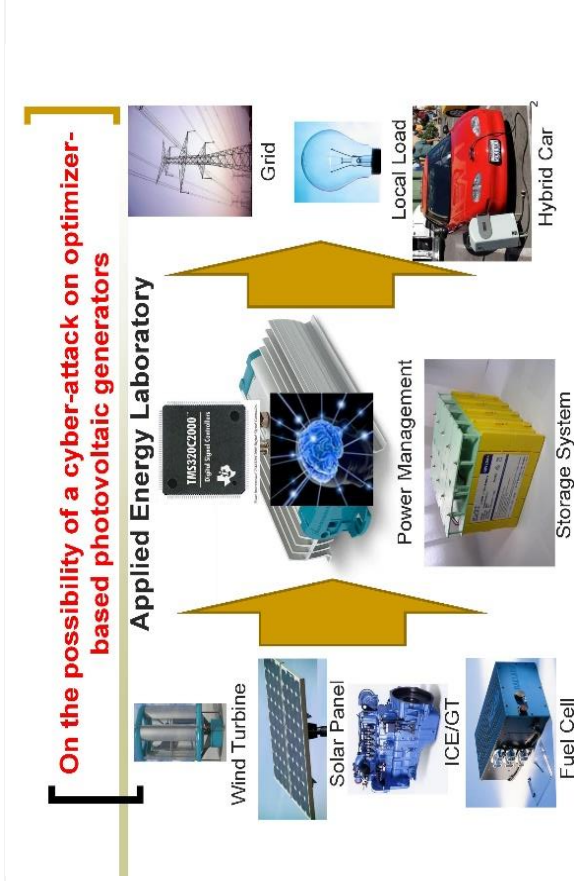

On the possibility of a cyber-attack on optimizer-based photovoltaic generators

Applied Energy Laboratory

On the possibility of a cyber-attack on optimizer-based photovoltaic generators

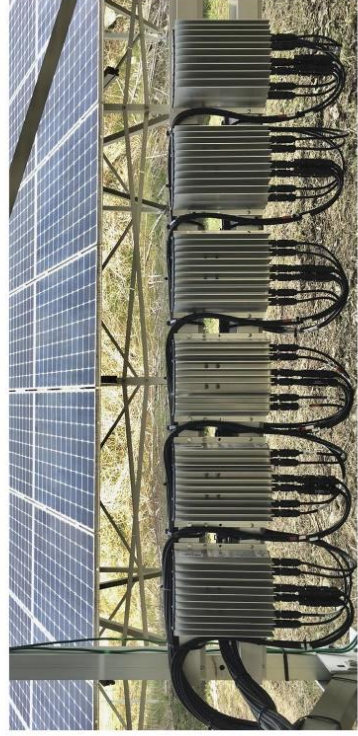

Typical Photovoltaic (PV) system

On the possibility of a cyber-attack on optimizer-based photovoltaic generators

The diagram shows a typical PV system consisting of a solar panel array connected to a controller, which is then connected to the AC grid. A large red 'X' is drawn over the controller, and a lightning bolt labeled 'Attack' points to it, indicating a cyber-attack on the system.

5

On the possibility of a cyber-attack on optimizer-based photovoltaic generators

PV module overheating and failures

Three images illustrating PV module overheating and failures: a thermal map showing hot spots, a close-up of a hot spot on a module, and a cracked module.

“Hot spot”

6

On the possibility of a cyber-attack on optimizer-based photovoltaic generators

The diagram shows a typical PV string connected to a controller, which is then connected to the AC grid. A large red 'X' is drawn over the controller, and a lightning bolt labeled 'Attack' points to it, indicating a cyber-attack on the system.

Typical PV string

IV curve of the solar cell
The short circuit current, I_{sc} , is the maximum current from a solar cell and occurs when the voltage across the device is zero.

Power from the solar cell

Output characteristics of a single PV module

Two graphs showing the output characteristics of a single PV module. The left graph shows the IV curve (Current vs. Voltage) with the short circuit current I_{sc} and the maximum power point (MPP) marked. The right graph shows the P-V curve (Power vs. Voltage) with the maximum power point (MPP) marked.

7

On the possibility of a cyber-attack on optimizer-based photovoltaic generators

Ideal PV string – similar IV characteristics of PV modules

The diagram shows an ideal PV string connected to a controller, which is then connected to the AC grid. A large red 'X' is drawn over the controller, and a lightning bolt labeled 'Attack' points to it, indicating a cyber-attack on the system.

Output characteristics of PV string

$$P_{string} = \sum_n P_{max,n} = n \cdot P_{max}$$

A graph showing the output characteristics of a PV string, plotting Current vs. Voltage. The maximum power point (MPP) is marked on the curve.

8

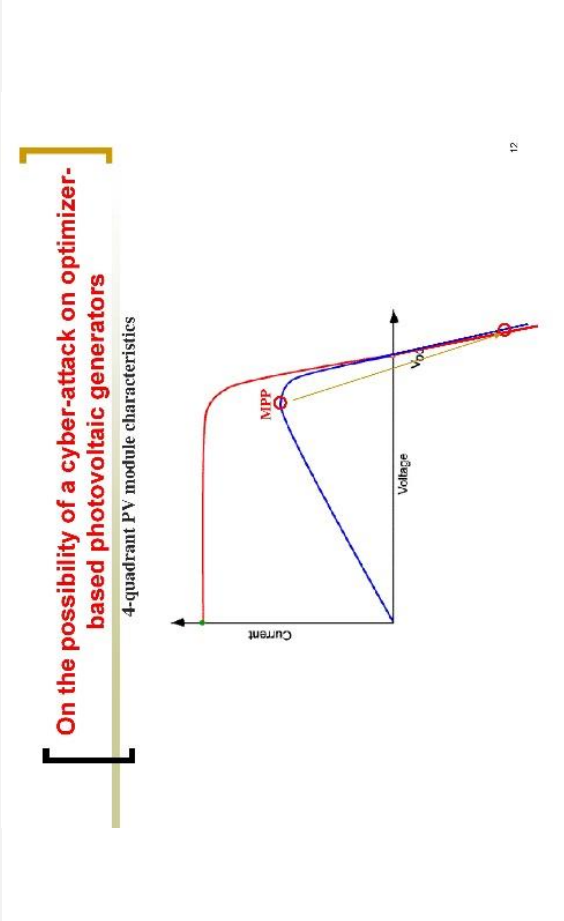
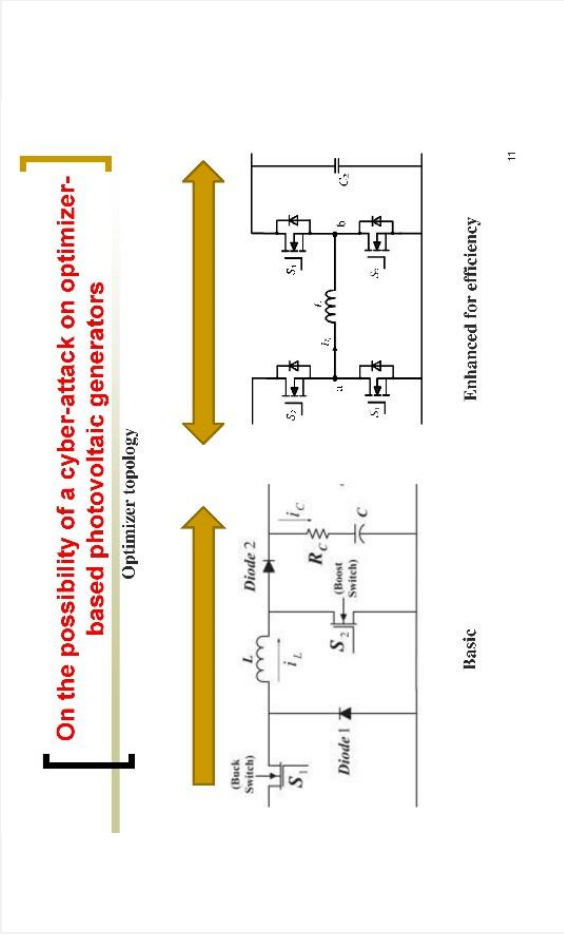
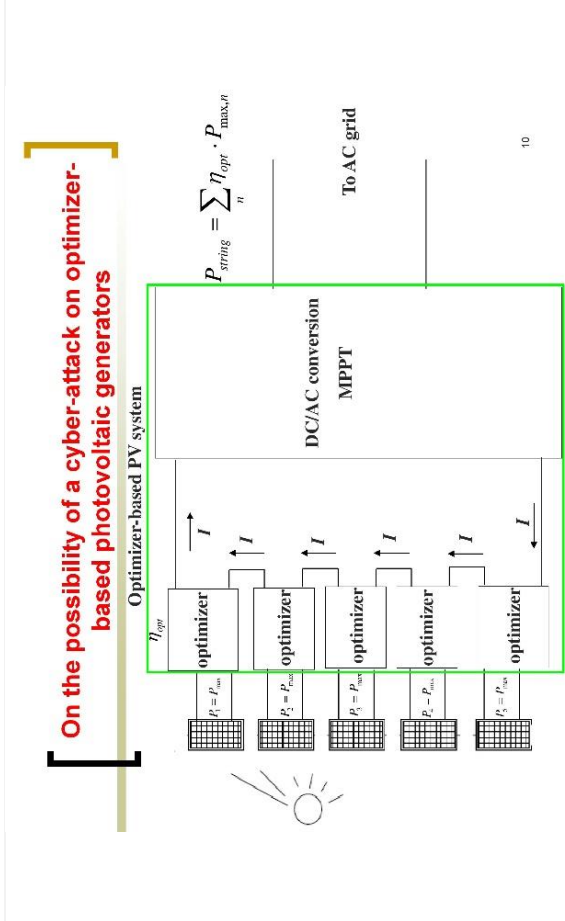
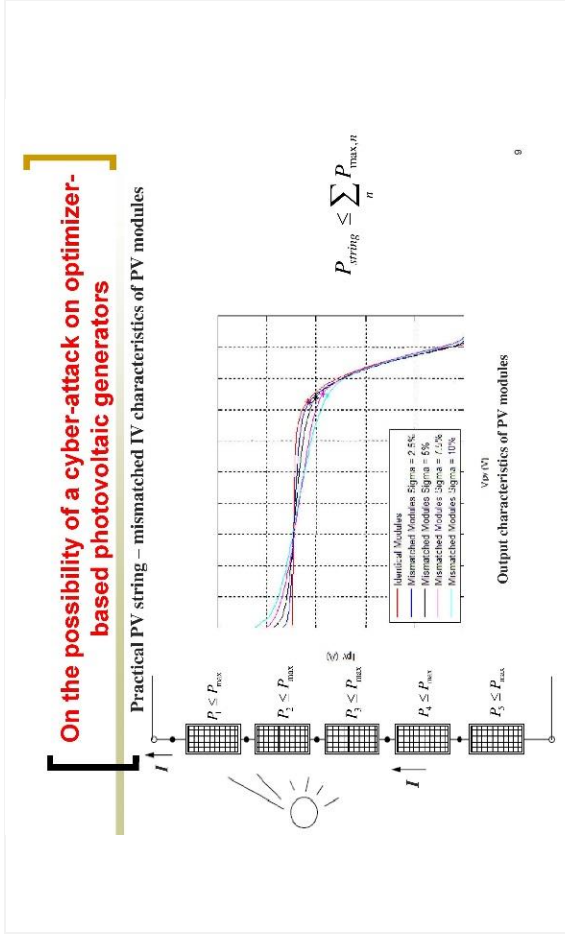

On the possibility of a cyber-attack on optimizer-based photovoltaic generators

Experimental Setup



13

On the possibility of a cyber-attack on optimizer-based photovoltaic generators

Normal operation

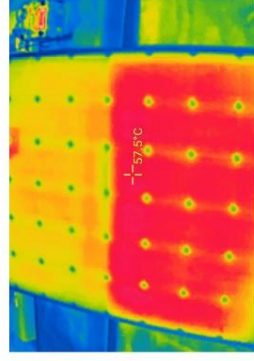

14

On the possibility of a cyber-attack on optimizer-based photovoltaic generators

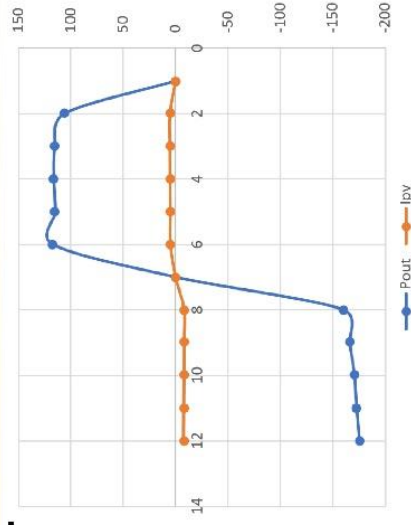

15

On the possibility of a cyber-attack on optimizer-based photovoltaic generators

Attack

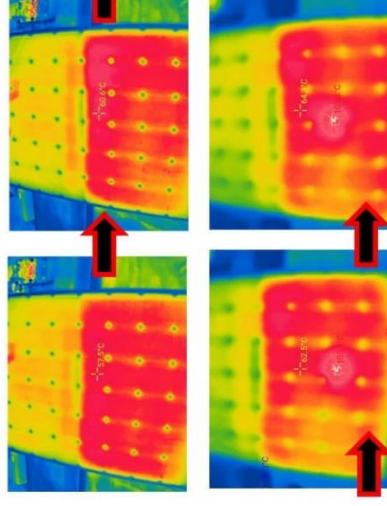

16

[On the possibility of a cyber-attack on optimizer-based photovoltaic generators]



School of Electrical and Computer Engineering
Ben-Gurion University of the Negev



Cyber@Ben-Gurion University of the Negev
CBG



17

DAY 3: Brokerage event

Session 1 – Projects

Numerical evaluation of the impact of some design parameters of centrifugal fans on their energy efficiency. Corresponding algorithm in the Python language

Dr. Spartak POCARI, Polytechnic University of Tirana, Energy Department

Dr. Luis LAMANI, Polytechnic University of Tirana; Geoinformatic Division

Prof. Dr. Andonaq LONDO, Polytechnic University of Tirana, Energy Department ¹

¹*Corresponding author*

Tel: +355 686011885

Fax: + 355 42223707

e-mail: alondo@fim.edu.al

Address: Polytechnic University of Tirana; Sheshi "Nene Tereza" No.1 Tirana-Albania

Abstract

Energy consumption in fans today is one of the main problems facing the industry of their production and exploitation. Optimal sizing of the fans in the design stage is a key leverage point for energy efficiency and system performance.

In this paper the authors will look into the influence of the inlet gap effect on the aerodynamic parameters of the fan and therefore on its energy efficiency. The measurements were carried out in a specially test stand in the energy laboratory of UPT. The impeller is mounted on the suction side of the chamber test stand. There is a gap between the nozzle section side and the impeller of fan, the size of which affects the performance of the fan and therefore its energy efficiency. The effect of different values of the gap on the performance of the fan are presented in the paper. The authors also aim to compare the experimental measurements made in the test stand in the energy department of UPT with the results of the mathematical model with the Python programming language.

Keywords: Fans, energy efficiency, evaluation, Python language.

1. Introduction

Due to increasing energy cost and the challenges in the context of climate change there is a permanent demand to enhance the energy efficiency of fans. Increasing the energy efficiency of the centrifugal fan is completely dependent on the optimal design of the rotor and other components of the plant. The design of a thermofluidic machine begins with the dimensioning of the rotor, as the most important constructive element of the machine.

The design of other elements is a function of the rotor's design. In fig. 1, the most important constructive parameters of a centrifugal rotor are shown. Many authors give their empirical considerations on the numerical evaluation of these constructive parameters. Numerical models on these calculations can be found in the work of authors (Carolus Th., 2022).

Optimizing the constructive design of a centrifugal rotor requires that the flow of the fluid in the flow space between the blades is done with the smallest possible losses. Energy losses in the rotor depend on the constructive parameters of the rotor as well as on other parameters such as the speed of the rotor shaft, etc. The minimization of losses increases the energy performance of the rotor, therefore also the energy efficiency of the rotor. There is a gap l_s , figure 2 between the nozzle section side and the impeller of fan, the size of which affects the performance of the fan and therefore its energy efficiency. The effect of different values of the gap on the performance of the fan are presented in the paper.

Axial gap overlap l_s (Figure 2) is given by Carolus Th., 2022:

- Blade shape backwards curved $0-0.08 D_1$ (1)
- Blade shape forward curved Axial gap permissible up to $0.03 D_2$ (2)

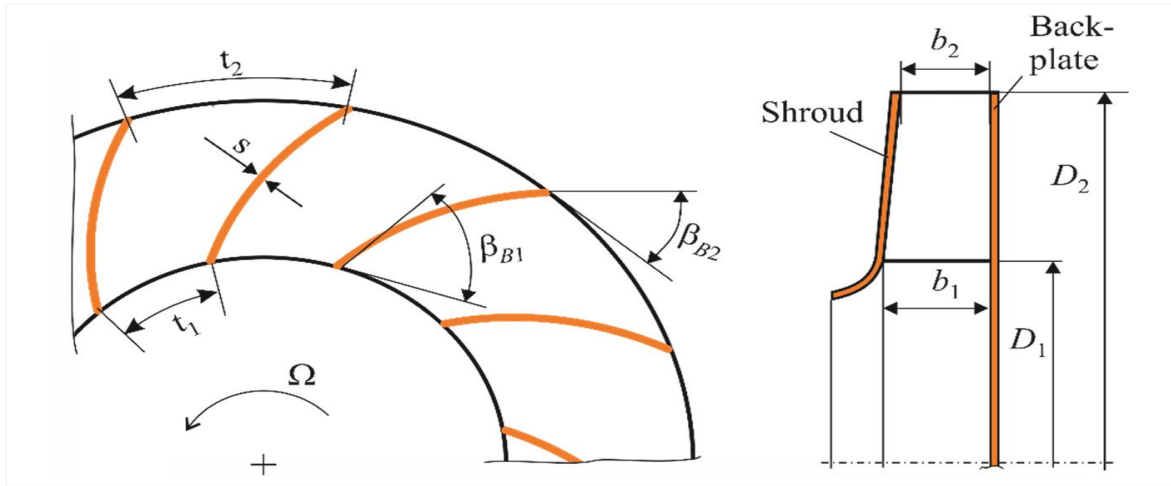

Figure 1: Nomenclature of the centrifugal impeller.

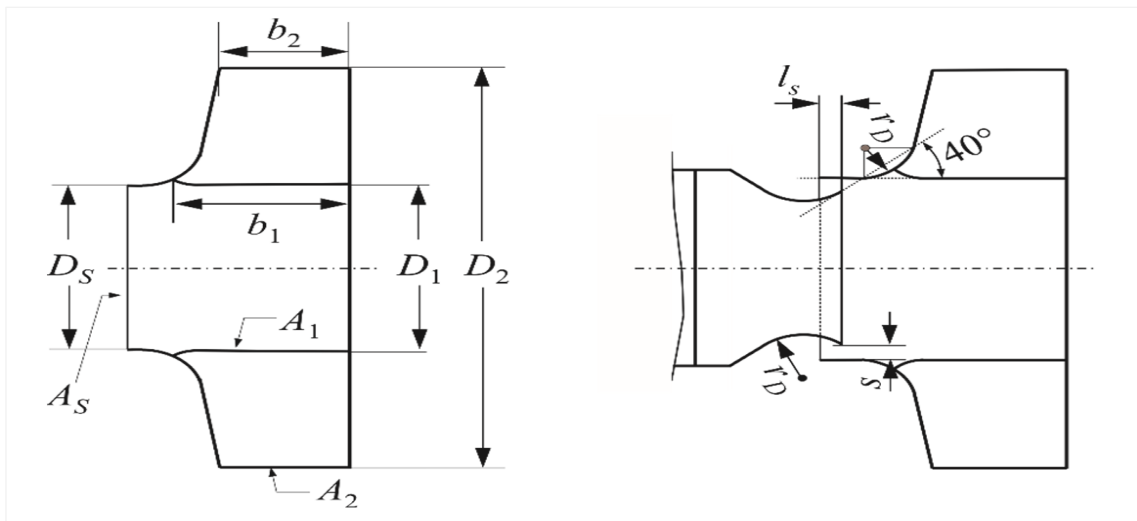

Figure 2: Further geometry parameters of the centrifugal impeller with backward curved blades and the inlet nozzle.

2. Mathematical model of the fan characteristic

2.1 Fan performance parameters

The most important aerodynamic performance parameters of a fan are the volume flow rate \dot{V} of the gaseous fluid conveyed by the fan in units of m^3/s and the total pressure rise Δp_t in units of Pa.

The designer's choice of several geometrical parameters determines the values of flow velocities in the machine which have a direct effect on the losses. Given its density ρ , equivalent fan performance parameters are:

- the mass flow through the fan $\dot{m} = \rho \cdot \dot{V}$ in kg/s and
- the specific work done by the fan on the fluid in Joule/kg or Watt / (kg/s) $Y_t = \frac{\Delta p_t}{\rho}$.

It is evident that Δp_t , like Y_t , is an energetic quantity. The total pressure rise is the difference in the total pressures between the fan inlet and exit. In general, it comprises a rise in both, static and dynamic pressure:

$$\Delta p = p_{t,exit} - p_{t,inlet} \quad (3)$$

$$p_{t,exit} = p_{st,exit} + p_{d,exit}$$

$$p_{t,inlet} = p_{st,inlet} + p_{d,inlet}$$

$$\Delta p = (p_{s,exit} - p_{s,inlet}) + (p_{d,exit} - p_{d,inlet}) \quad (4)$$

The dynamic pressure is always $\left(\frac{\rho}{2}\right) \cdot c^2$, with the fluid velocity $c = c_{in}$ and c_{exit} at the fan inlet and exit, respectively. The shaft power a motor must supply to the fan impeller is calculated from the shaft torque M_s and the impeller shaft speed n as $P_s = M_s \cdot 2 \cdot \pi \cdot n$

The total efficiency of the fan is the ratio

$$\eta = \frac{\dot{m}}{M_s \cdot 2 \cdot \pi \cdot n} \cdot Y_t \quad (5)$$

2.2 Non-dimensional parameters

Non-dimensional parameters are used for the design, comparison and evaluation of fluidic machines. The numerical values of these parameters are independent of the pressure, flow and physical properties of the fluid. The most important non-dimensional parameters used in fluid machines are given in Table 1. The characteristic of the fan taken in the study with non-dimensional parameters is given in Figure 3. This characteristic was obtained in the laboratory of thermo fluidic machines at energy department at PUT.

3. Results of the mathematical model and experimental measurements

Based on the mathematical model for evaluating the dimensionless parameters of the fan, an algorithm was designed in the PYTHON programming language, through which we can obtain the characteristics of the fan (See in 3.1).

3.1 Program installed in the Arduino Circuits for the processing of the signal coming from the pressure sensors (PYTHON language)

```
DFRobot_LWLP lwlp;
void setup() {
```

```
Serial.begin(9600);
//Init Chip
while (lwlp.begin() != 0) {
Serial.println("Failed to initialize the chip,
please confirm the chip connection");
delay(1000);
}}
void loop(void){
DFRobot_LWLP::sLwlp_t data;
//Get data of single measurement
data = lwlp.getData();
//Get data processed by the filter
//data = lwlp.getfilterData();
//Get temperature in unit centigrade degree
Serial.print(data.temperature);
Serial.print(",");
//Get pressure difference in unit pa
Serial.print(data.presure);
Serial.println("");
delay(1);
```

3.2 Results of experimental measurements

To evaluate the influence of the gap between the fan rotor and the nozzle, shown schematically in Figure 2, and in the experimental device in Figure 4, we performed some experimental measurements for different values of the gap ls, for the same number of the speede.

The experimental equipment was designed in the laboratory of thermofluidic machines. Some of its elements are presented in Figures 4, 5, 6, 7.

Table 1: Most important non-dimensional parameters used in fluid machines.

Designation	Definition
Volume flow rate coefficient	$\phi = \frac{\dot{V}}{\frac{\pi^2}{4} \cdot D^3 \cdot n}$
Pressure rise coefficient	$\psi_t = \frac{Y_t}{\frac{\pi^2}{4} \cdot D^2 \cdot n^2}$
Power coefficient	$\lambda = \frac{P_s}{\left(\frac{\pi^4}{8}\right) \cdot \rho \cdot D^5 \cdot n^3}$
Specific speed	$\sigma = \frac{n}{(2 \cdot \pi^2)^{\frac{1}{4}} \cdot Y_t^{\frac{3}{4}} \cdot \dot{V}^{-\frac{1}{2}}}$
Specific diameter	$\delta = \frac{D}{(8/\pi^2)^{\frac{1}{4}} \cdot Y_t^{-\frac{1}{4}} \cdot \dot{V}^{\frac{1}{2}}}$
Overall efficiency	$\eta = \frac{\dot{m}}{P_s} Y_t = \frac{\dot{V} \cdot \Delta p_t}{M_s \cdot 2\pi n}$

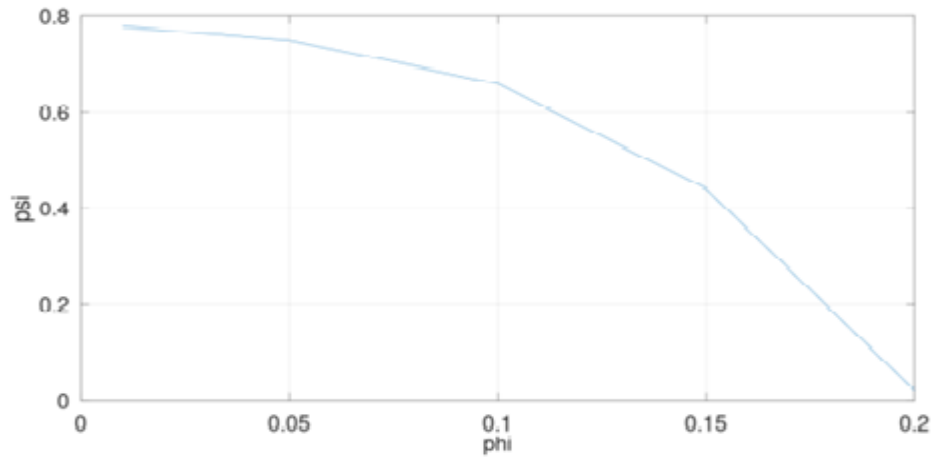

Figure 3: The dimensionless characteristic of the fan LR V3.1 CMV pro 200 ($\varphi = f(\phi)$) Source: Laboratory of thermofluidic machines of the energy department at UPT.

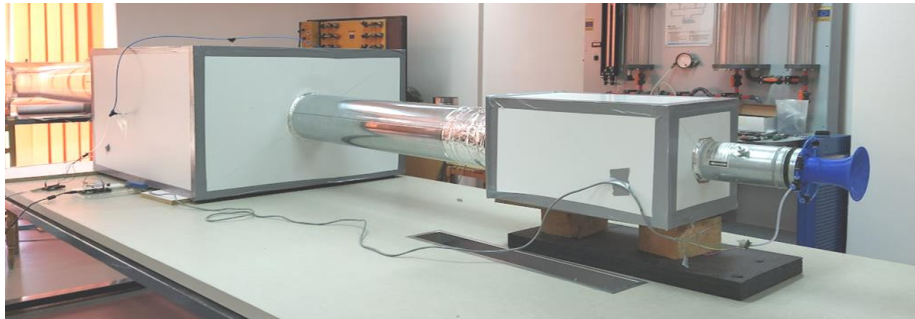

Figure 4: Fan characteristic testing device. Laboratory of thermofluidic machines PUT.

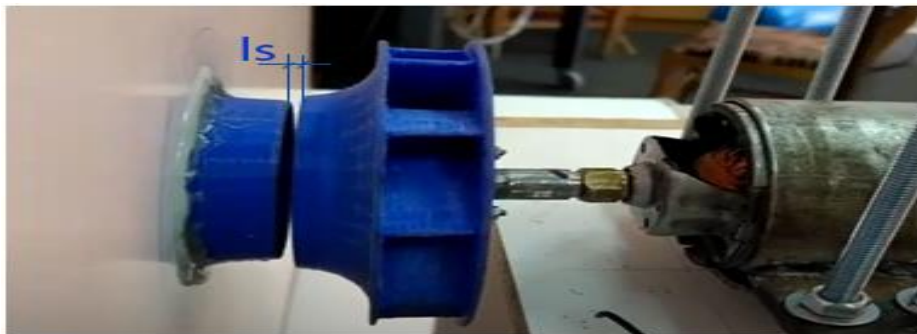

Figure 5: The fan in the test device. Gap Is .

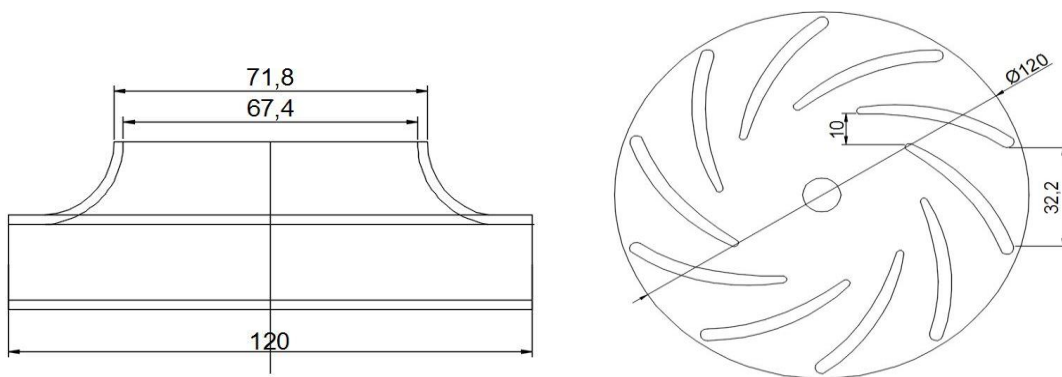

Figure 6: The design of the fan.



Figure 7: Flow rate valve located at the entrance of the experimental device.



Figure 8: The grid, placed in the device to linearize the air flow before the measurement by the pressure sensor.

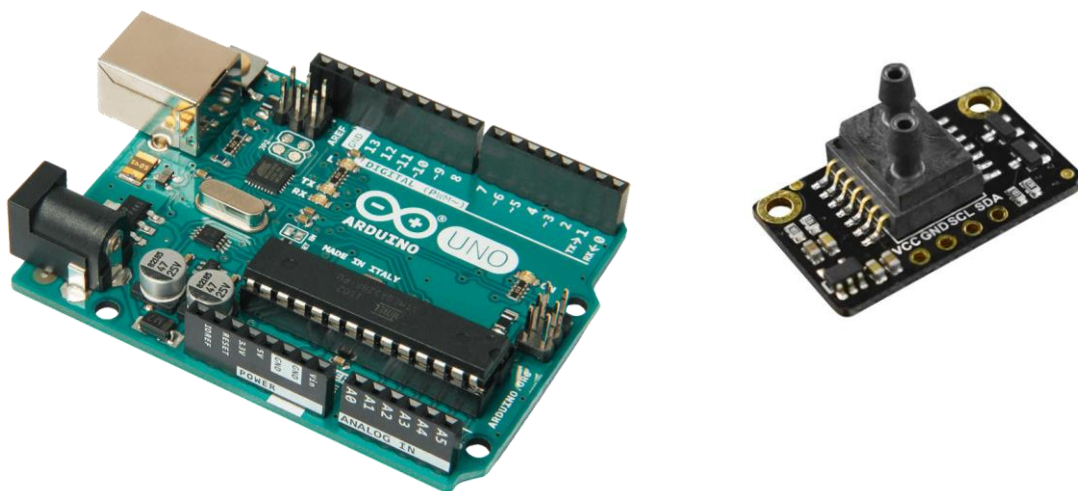

Figure 9: The arduino Uno programmable device and the sensor used for pressure measurement.

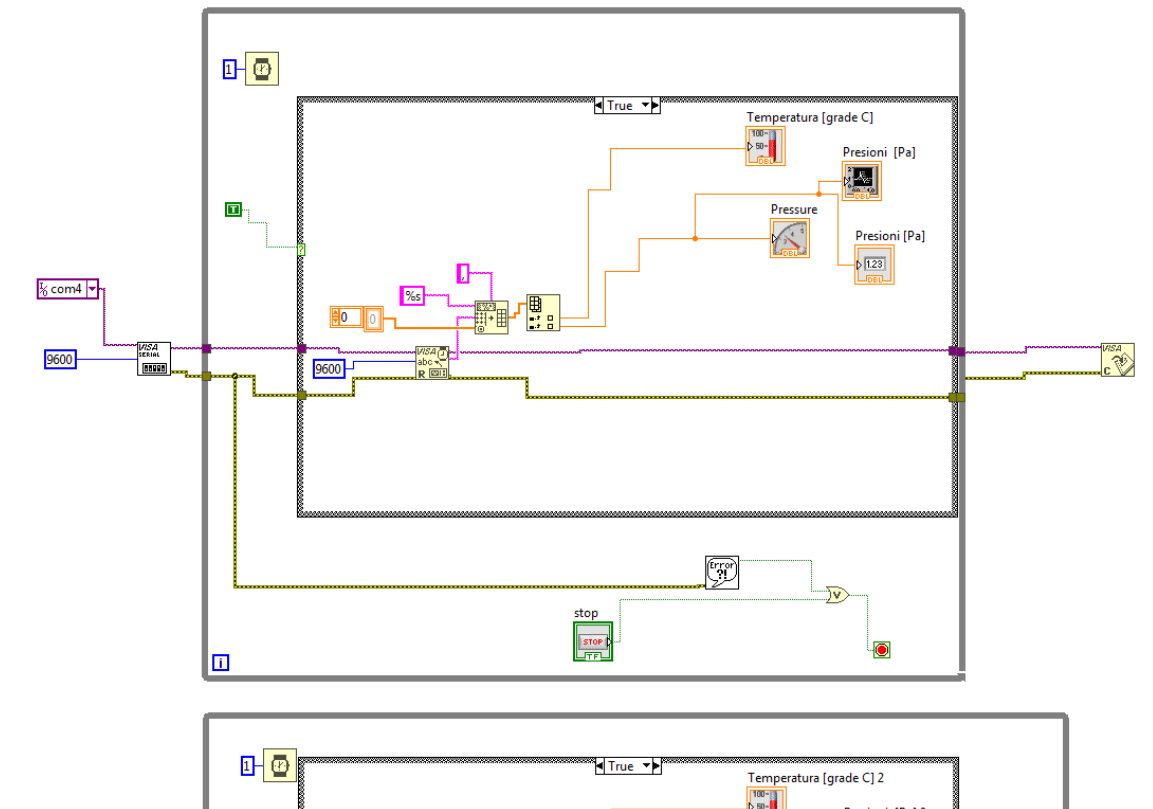
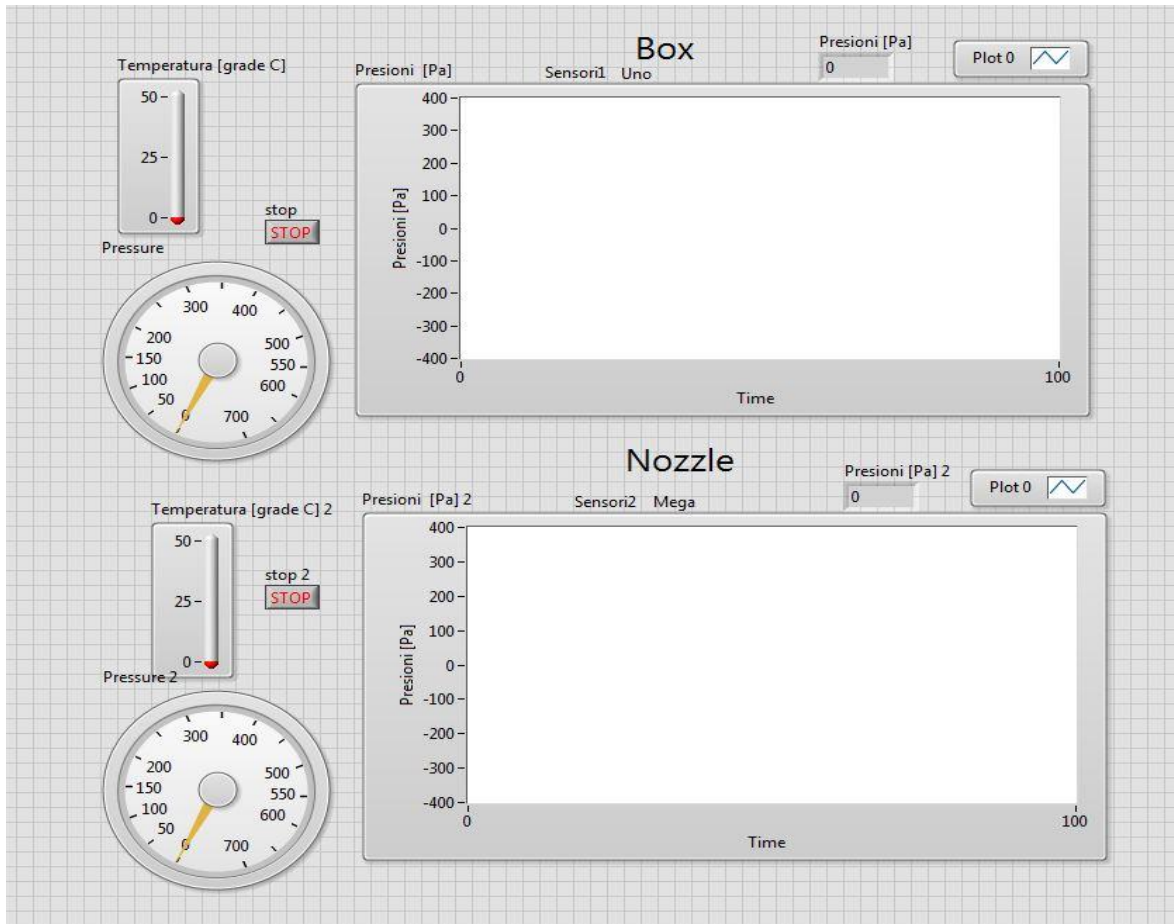

Figure 10: The program design in LabView for measuring pressure and flow.

Table 2: The results obtained for the value of the gap $l_s=0.25\text{mm}$ and impeller shaft speed 1337 rrot/min.

Measurement Nr.1		GAP= 0.25 mm		1337 rot/min					
Valve Opening %	P [Pa]	Axial Fan	Q[m ³ /s]	P [pa]	λ	$k*Q^2$	ϕ	ψ	Efficiency
	Diza			Kutia					
0%	0	OFF	0.0000	33	0	0.000000	0	3.846	#DIV/0!
25%	5	OFF	0.0058	29	0.512849	0.000041	0.1264	3.380	0.83
50%	8	OFF	0.0074	26	0.581601	0.000066	0.1599	3.030	0.83
75%	10	OFF	0.0083	25	0.62524	0.000082	0.1788	2.914	0.83
100%	10	OFF	0.0083	25	0.62524	0.000082	0.1788	2.914	0.83
		ON (POS 1)	0.0111	20	0.671078	0.000147	0.2399	2.331	0.83
		ON (POS 2)	0.0123	16	0.593524	0.000180	0.2652	1.865	0.83
		ON (POS 3)	0.0150	8	0.363458	0.000270	0.3249	0.932	0.83
		ON (POS 3)	0.0165	0	0	0.000328	0.3577	0.000	#DIV/0!

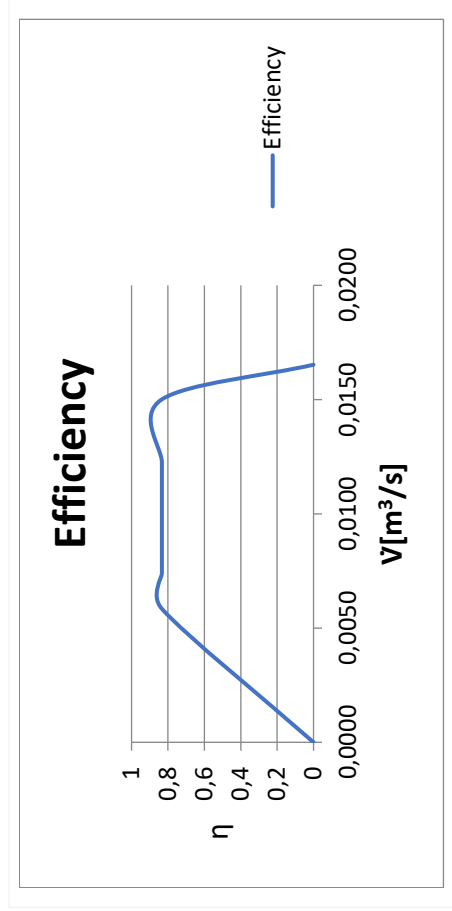
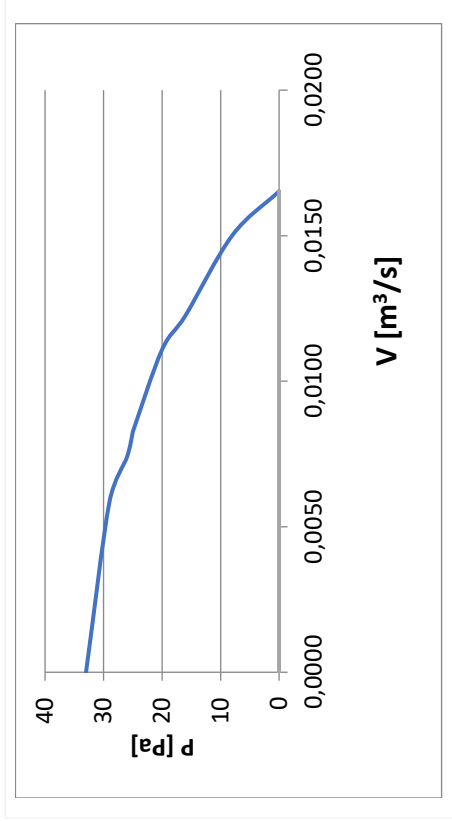

Figure 11: Fan's characteristics and overall efficiency $l_s=0.25\text{mm}$ and impeller shaft speed 1337 rot/min.

Table 3: The results obtained for the value of the gap $l_s=2,5\text{mm}$ and impeller shaft speed 1337 rrot/min.

Measurement Nr.4

		GAP= 2.5 mm		1337 rot/min					
Valve Opening %	P [Pa]	Axial Fan	Q[m3/s]	P [pa]	λ	$k*Q^{\wedge}2$	ϕ	ψ	Efficiency
	Diza			Kutia					
E Mbullur	0%	0	0.0000	29	0	0	0	3.380	#DIV/0!
	25%	4	0.0052	25	0.395	0.000033	0.113	2.914	0.833
	50%	7	0.0069	23	0.481	0.000057	0.150	2.681	0.833
	75%	8	0.0074	22	0.492	0.000066	0.160	2.564	0.833
	100%	9	0.0078	21	0.498	0.000074	0.170	2.447	0.833
	100%	15	0.0101	18	0.551	0.000123	0.219	2.098	0.833
	100%	20	0.0117	12	0.424	0.000164	0.253	1.399	0.833
	100%	30	0.0143	0	0	0.000246	0.310	0	#DIV/0!

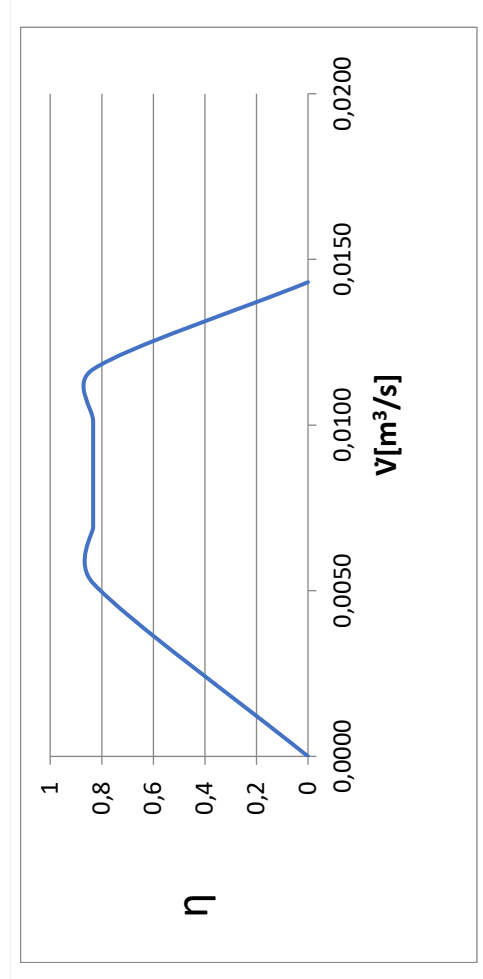
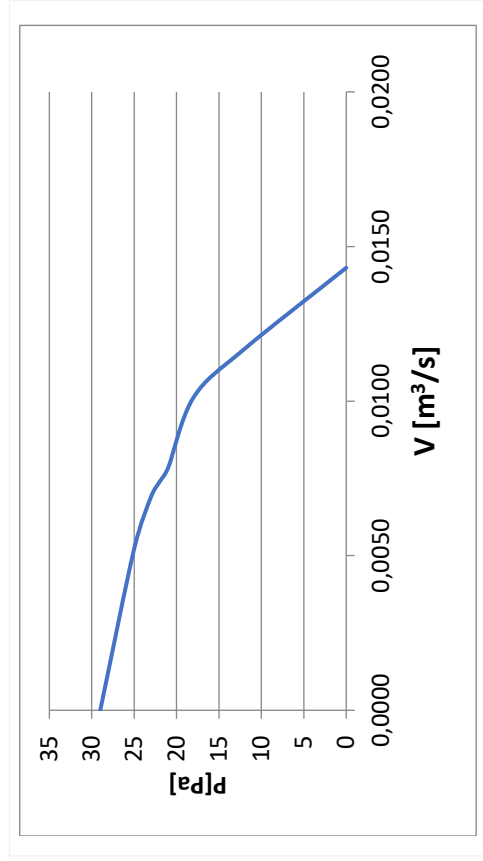

Figure 12: Fan's characteristics and overall efficiency $l_s=2,5\text{mm}$ and impeller shaft speed 1337 rot/min.

Table 4: The results obtained for the value of the gap $l_s=8\text{mm}$ and impeller shaft speed 1337 rrot/min.

Measurement Nr.5		GAP= 8 mm		1337 rot/min					
Valve Opening %	P [Pa]	Axial Fan	Q[m3/s]	P [pa]	λ	$k \cdot Q^2$	ϕ	ψ	Efficiency
	Diza			Kutia					
0%	0	OFF	0.0000	25	0	0	0	2.914	#DIV/0!
25%	3	OFF	0.0045	22	0.301	0.000025	0.098	2.564	0.833
50%	5	OFF	0.0058	21	0.371	0.000041	0.126	2.447	0.833
75%	7	OFF	0.0069	19	0.398	0.000057	0.150	2.214	0.833
100%	8	OFF	0.0074	18	0.403	0.000066	0.160	2.098	0.833
100%	12	ON (POZ 1)	0.0091	14	0.384	0.000098	0.196	1.632	0.833
100%	16	ON (POZ 2)	0.0105	8	0.253	0.000131	0.226	0.932	0.833
100%	20	ON (POZ 3)	0.0117	0	0	0.000164	0.253	0	#DIV/0!

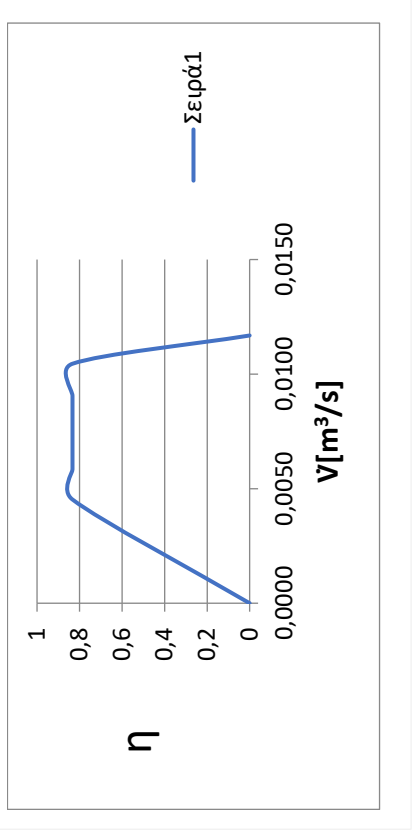
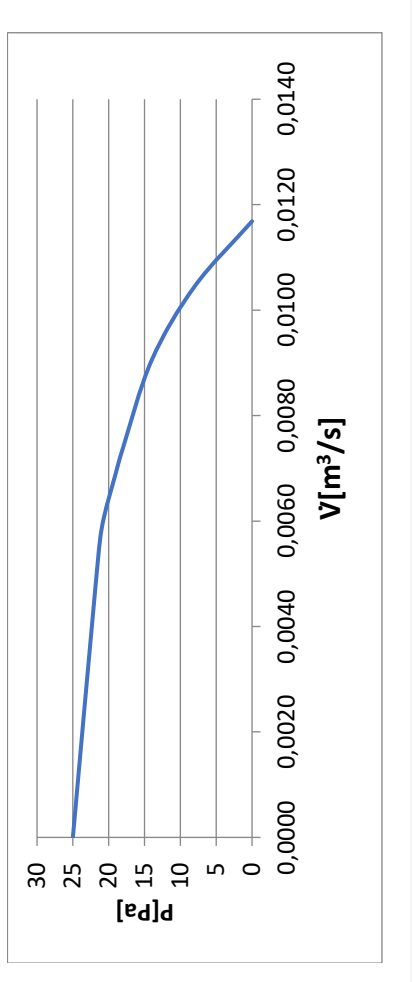

Figure 13: Fan's characteristics and overall efficiency $l_s=8\text{ mm}$ and impeller shaft speed 1337 rot/min.

Table 5: The results obtained for the value of the gap $l_s=12\text{mm}$ and impeller shaft speed 1337 rrot/min.

Measurement Nr.5		GAP= 12 mm		1337 rot/min					
Valve Opening %	P [Pa]	Axial Fan	Q[m3/s]	P [pa]	λ	$k \cdot Q^{\wedge}2$	ϕ	ψ	Efficiency
	Diza			Kutia					
0%	0	OFF	0.0000	22	0	0	0	2.564	#DIV/0!
25%	2	OFF	0.0037	19	0.213	0.000016	0.080	2.214	0.833
50%	4	OFF	0.0052	16	0.253	0.000033	0.113	1.865	0.833
75%	5	OFF	0.0058	15	0.265	0.000041	0.126	1.748	0.833
100%	7	OFF	0.0069	14	0.293	0.000057	0.150	1.632	0.833
100%	13	ON (POZ 1)	0.0094	8	0.228	0.000107	0.204	0.932	0.833
100%	17	ON (POZ 2)	0.0108	0	0	0.000139	0.233	0	#DIV/0!
100%		ON (POZ 3)	0.0000		0	0	0	0	#DIV/0!
			0.0000		0	0	0	0	#DIV/0!

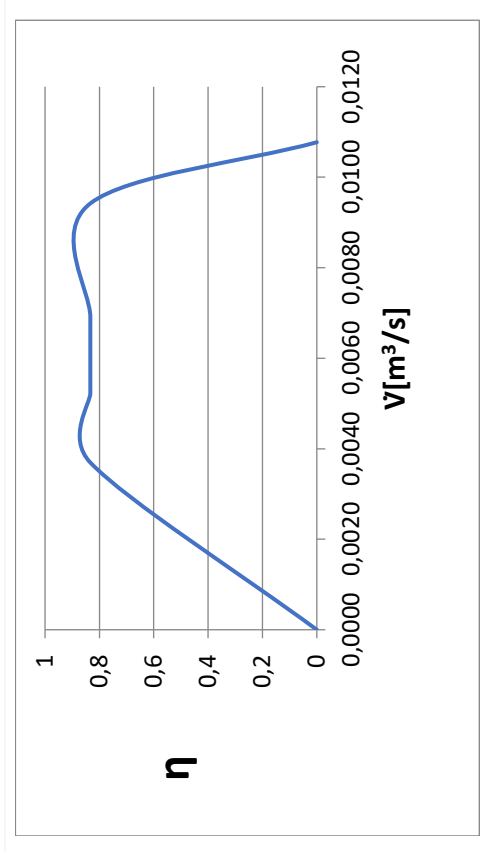
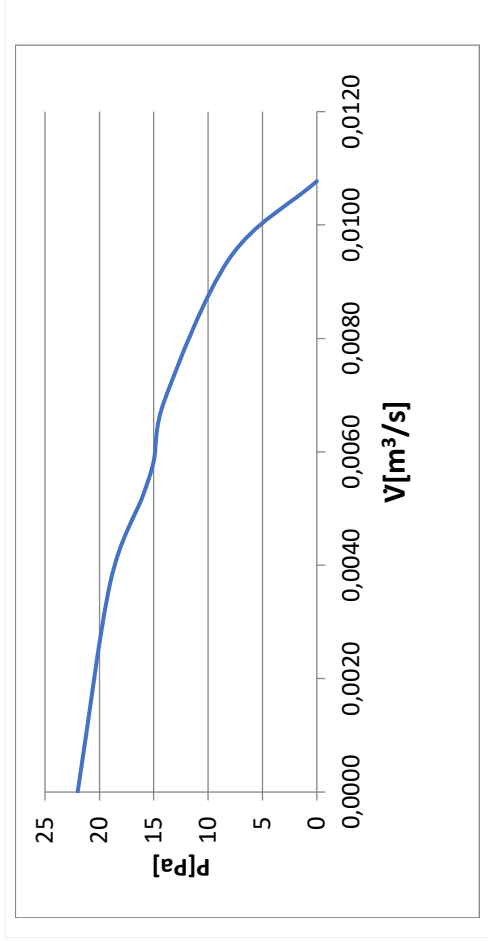

Figure 14: Fan's characteristics and overall efficiency $l_s=12\text{ mm}$ and impeller shaft speed 1337 rot/min.

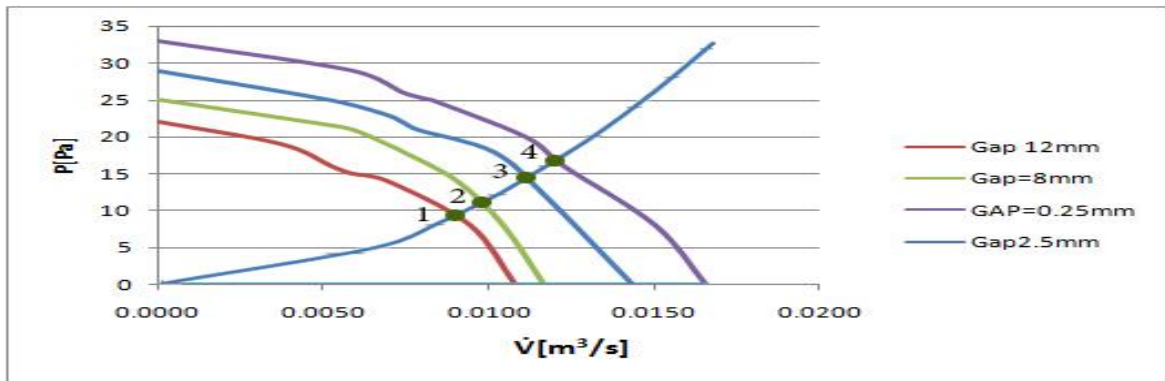

Figure 15: The characteristic's of the fan for the diferent value of gap.

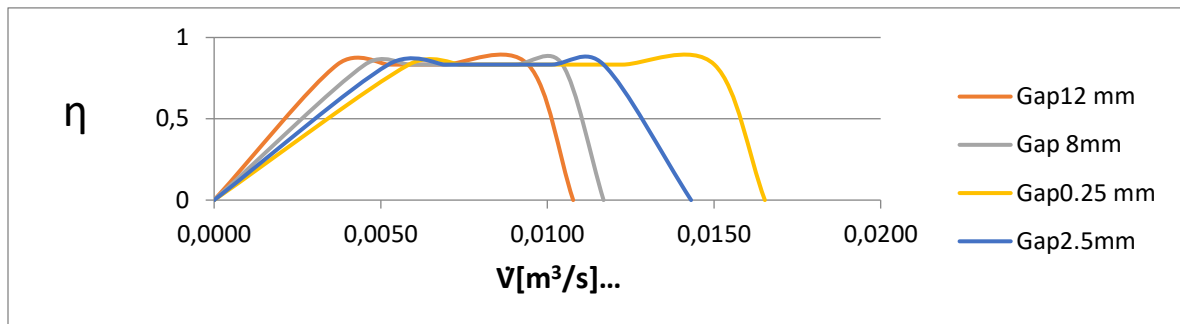

Figure 16: Overlay of graphs of fan's efficiency for different gap values 0.25mm, 2.5mm, 8 mm dhe 12 mm.

The signals obtained from the experimental measurements are processed by the sensors presented above and processed through the labview program Figure 9. Results are showed in Figures 10, 11, 12, 13 and 14 and the relevant Tables.

3.3 Processing results of experimental measurements

Through the testing device, the characteristics of the fan were obtained and its performance was evaluated, through the labview program. The results are presented in the following figures for different numbers of speed and different values of the space within the standard cited above in formulas (1) and (2).

4. Conclusions

Figure 16 shows that if the value of l_s is within the recommended values eq. (1) and (2), the maximum value of efficiency is almost constant.

1. The operating point of the system with the increase of the gap l_s moves to the lower left in the direction of decreasing the flow and pressure of the fan. So, from $l_s = 0.25$ mm to $l_s = 8$ mm in Figure 15, the pressure and flow of the fan will decrease respectively working point (from point 4 to point 1). This will be accompanied by a decrease in the efficiency of the fan.
2. For increased values of the gap, outside the recommended values given by equation (1) and (2), the maximum value of the efficiency remains almost constant figure 16, but the working area with maximum efficiency is significantly reduced. Thus, for a gap value of 0.25 mm, the working area with maximum efficiency is in the range of $0.0050 \text{ m}^3/\text{s}$ to $0.0155 \text{ m}^3/\text{s}$, while for a gap value of 12 mm, the working area with maximum efficiency is in the range of $0.0040 \text{ m}^3/\text{s}$ to $0.0011 \text{ m}^3/\text{s}$, so it decreases by about 9%.

References

Carolus H. Thomas, 2022. English Translation of the German Edition 2022. FANS, Aerodynamic Design - Noise and Noise Mitigation -Experimental and Numerical Methods - Optimization -System Integration. German Edition 2022. Springer Fachmedien, ISBN 978-3-658-37958-2.

Ottersten M., Yao H.-D., L. Davidson L., 2022. Inlet Gap Effect on Aerodynamics and Tonal Noise Generation of a Voluteless Centrifugal Fan. *Journal of Sound and Vibration*,. Volume 540, 8 December 2022, 117304, doi <https://doi.org/10.1016/j.jsv.2022.117304>

Gjeta Ardit, Bamberger Konrad, Carolus Thomas, Londo Andonaq, 2018. Parametric Study of Volutes for Optimal Centrifugal Fan Impellers. International conference “On fan noise, aerodynamics; applications and systems . Germany 2018. www.fan2018.org

British standard BS ISO 5801:2007; BS 848-1:2007. Industrial fans -performance testing using standardized airways. <https://www.en-standard.eu/une-en-iso-5801-2019-fans-performance-testing-using-standardized-airways-iso-5801-2017/>

[Docs.python.org; numpy.org/doc](https://docs.python.org/3.9/download.html) <https://docs.python.org/3.9/download.html>

Electricity Generation Using Solar Power in Industrial Application – Case Study

Prof. Assoc. Astrit BARDHI¹

Automation Department, UPT

Dr. Marjola PUKA

Lecturer at Electrotechnic Department, UPT

Dr. Alfred PJETRI

Lecturer at Automation Department, UPT

¹ *Contact details of corresponding author*

Tel: +355-42-238-60

Fax: +355-42-238-60

e-mail: asibardhi@gmail.com

Address: Polytechnic University of Tirana (UPT), Faculty of Electrical Engineering, “Sheshi Nënë Tereza”, Nr. 4, Tirana, Albania

Abstract

Electricity demand has increased in recent years, while energy prices have increased dramatically. In Albania, electricity is mainly produced by hydroelectric plants. The generation of energy from hydropower plants depends on the atmospheric conditions, and according to Albanian Energy Corporation data, their yearly electricity production covers about 70–80% of consumption. Solar energy conversion into electricity via photovoltaic panels (PV) is now more cost-effective and technologically advanced in terms of both cost and applications. As a result, in recent years, the interest of private companies in solar energy has increased. Already, in Albania, several photovoltaic parks are in various stages of construction. In this article, we will analyze a case study of electricity production through photovoltaic panels in industrial applications. Based on the data obtained from the measurements in the object, the electricity produced by the PV panels covers the company’s energy demands, and sometimes the pieces of energy production penetrate the power grid. We underline that the installation of photovoltaic panels to produce electricity is necessary and efficient. Furthermore, solar energy is one of the ways of renewable energy, due to the incremental rate of environmental concern, provides a significant interest.

Keywords: renewable energy, engineering, solar panels, power system, energy management.

1. Introduction

In Albania, the production of electricity is mainly carried out using hydropower plants, the most important of which are the hydropower plants built on the Drin River. During the last decade in Albania, several small hydropower plants with a total capacity of about 600 MW were built (ERE, 2021). In this way, the production of electricity depends on atmospheric precipitation. Energy production in Albania is facing difficulty supplying its consumers with electricity. Some of these difficulties include a lack of primary energy resources; no distribution network for natural gas; limited interconnection transmission line capacities; and full dependence on energy production by hydropower plants.

On the other hand, the demand for electricity in the country has increased significantly. The electricity produced at a certain time by plants does not cover the demands of consumers. Therefore, to provide electricity to consumers, a part of it is imported from abroad. Also, in the last few years, the electricity price has undergone a significant increase. The electricity prices have put both household consumers and the industrial sector in difficulty. In some cases, due to the increase in the price of electricity, some companies have gone towards closing their production processes, causing chain reactions in the country’s economy. Seeing the problems in the electricity sector, many consumers are looking at alternative ways to provide electricity (Solar Power Europe, 2017).

One of the most efficient ways the production of electricity is to use solar energy through the installation of solar panels. In recent years, the price of solar panels has decreased, and the interest from the private sector in their installation has increased.

In this article, we will analyze a case study of electricity production through the installation of solar panels in a plastic manufacturing company. The increase in energy prices put the company in financial difficulties. The installation of photovoltaic panels not only provided the necessary amount of energy but also injected the surplus into the electrical system. The advantages of producing electricity through solar panels are that they are simple to install, require minimal maintenance, their installation time is very short, and are environmentally friendly. A disadvantage is that photovoltaic panels require a considerable surface area and the production of energy is realized only during sunny hours.

Another target of this paper is the recommendation to install photovoltaic panels on the roofs of buildings.

2. A brief history of the development of solar energy in Albania

Table 1 presents data on electricity production for all categories of producers that are in operation in Albania during the year 2021 (ERE, 2021). As shown in Table 1, where the main contribution to energy production during the year 2021 is by KESH s.a., a public company. As shown in Table 1 the photovoltaic plants have produced 40,756 MWH or about 0.5 % of total energy production during the year 2021.

Albania, with a favorable geographical position in the Mediterranean basin, has a good climate condition for the use of solar radiation for electricity production. The high intensity

and duration of solar radiation, the temperature, and humidity of the air, etc. determine the energy potential of solar energy.

The territory of Albania lies in the western part of the Balkan Peninsula on the eastern coast of the Adriatic and Ionian seas. It is located between latitudes 39° 38' - 42° 38' and longitudes 19° 16' - 21° 04'. In the territory of our country, we have a considerable solar energy potential where many areas are exposed to radiation ranging from 1,185 kWh/m² per year to 1,700 kWh/m² per year. It is worth mentioning that the western part of Albania, especially the southwest, has significant solar energy, which goes up to 2,200 kWh per year.

In Figure 1, the isoline of 1,500 kWh/m² per year divides the territory of Albania into two almost equal parts (NANR, 2015). Each meter square of the horizontal surface in this part of the territory has the practical possibility of receiving up to 2,200 kWh/m² per year. In any weather condition, the same surface receives approximately 1,700 kWh per year. Table 2 shows the capacity of average solar energy production in some regions during the year. As shown by the data in the Tirana and Vlora regions, where industrial activity is centralized, the capacity of solar energy per day has higher values than in other regions. Table 3 shows the capacity of installed solar plants until 2021 in Albania. Also, Table 3 shows the energy production by solar plants during the year 2021.

Solar energy is a very promising source of energy for the future and its use is potential as it is an inexhaustible natural source of energy, it is the largest natural reserve of energy that is distributed everywhere in the world in great quantities, it is clean and its use does not require other expenses (Alirezai M. et al., 2016). It does not cause any risk of environmental pollution.

Table 1: Energy production of the year 2021 (ERE, 2021).

Type of generation	Yearly energy production [MWH]
PPE/ hydropower connection at OSSH	877,726
PPE/ hydropower connection at OST	951,505
Private hydropower connection at OST	1,425,989
Lanabregas hydropower	27,504
Ashta hydropower	295,245
Photovoltaic plant	40,756
Hydropower menage by KESH	5,343,974
TOTAL	8,962,699

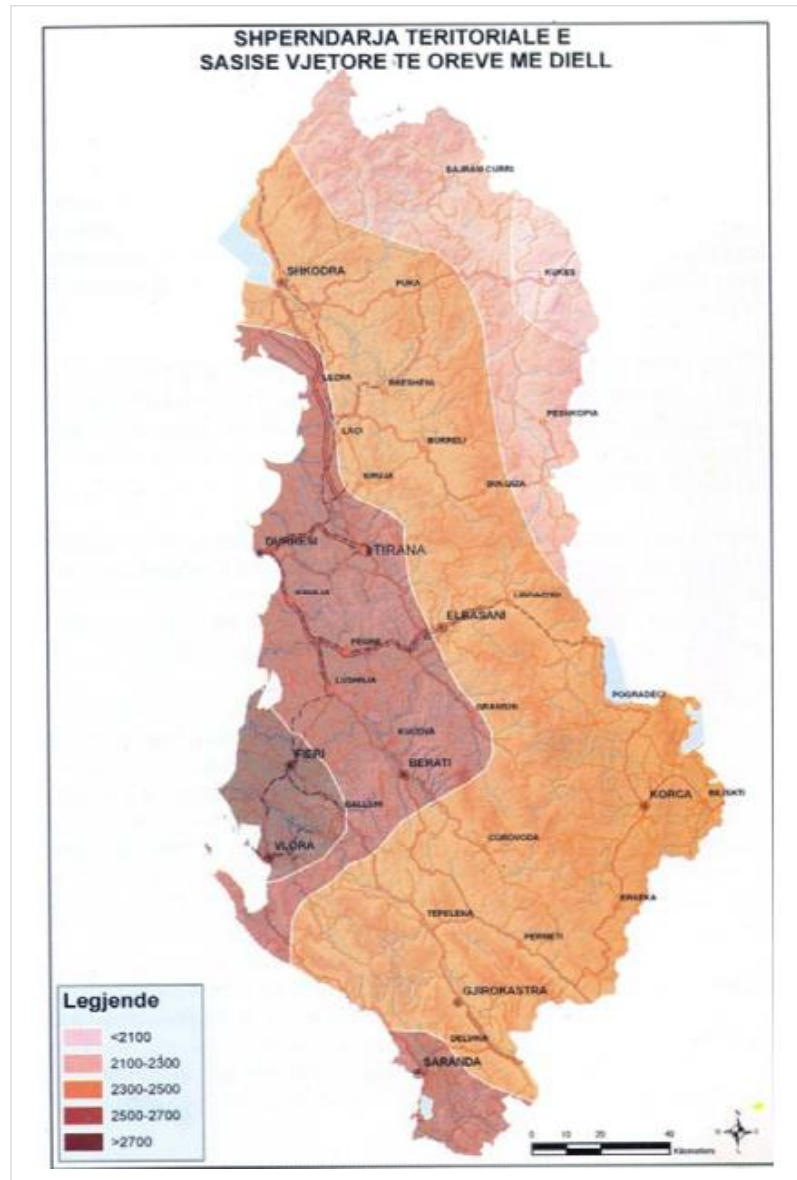

Figure 1: The territorial distribution of the annual sunny hours in Albania (Source: NANR, 2015).

Table 2: Yearly radiation (kWh/m² per day).

Region	Shkoder	Diber	Tirana	Vloora	Korça	Saranda
January	1.70	1.55	1.80	2.15	1.90	1.90
February	2.30	2.30	2.50	2.85	2.70	2.40
Marty	3.35	3.25	3.40	3.90	3.40	3.60
April	4.50	4.15	4.20	5.00	4.40	4.80
May	5.45	5.25	5.55	6.05	5.60	5.80
June	6.10	5.85	6.40	6.80	6.40	6.80
July	6.50	6.25	6.70	7.20	6.80	6.10
August	5.55	5.45	6.05	6.40	5.90	4.80
September	4.45	4.35	4.70	5.15	4.70	3.60
October	2.90	2.90	3.20	3.50	3.10	3.20
November	2.10	1.85	2.15	2.40	2.10	2.10
December	1.70	1.50	1.75	1.85	1.80	1.80

Table 3: Yearly solar energy production.

Solar plant	Installed capacity	Grid connection	Energy production
	MW	kV	MWH
“seman2sun”	2	35	4,021
"Sonne"	2	35	4,001
“aed solar”	2	35	4,001
“age Sunpower"	2	35	3,950
“Seman Sunpower”	2	35	4,049
“Semanisolar”	2	35	3,950
ES 2019	2	35	4,304
“Smart watt	2	35	4,290
RTS	2	35	3,668
Statkraft	2	35	13
AEE	2	10	4,469

Table 4: Monthly invoice by OSHEE of a plastic manufacturing company.

Month	Active energy billing	Invoice value [Euro]
January	100,700	20,140
February	98,720	19,744
Marty	112,340	22,468
April	120,370	24,074
May	105,750	21,150
June	123,475	24,695
July	120,450	24,090
August	122,370	24,474
September	110,430	22,086
October	99,390	19,878
November	107,890	21,578
December	115,740	23,148

3. Installation of photovoltaic panels at a plastic manufacturing company (Atearjo company)

As pointed out at the beginning of the paper, in the last year there has been an increased interest in the production of electricity through the installation of photovoltaic panels. In this paragraph, there is an analysis of the case study of the installation of photovoltaic panels in a plastic manufacturing company, “ATEARJO”. The "ATEARJO" company is supplied by a line of 20 kV connected to a distribution power system. The power transformer which is installed at the object is 1 MVA rated power. Table 4 shows the monthly invoice (energy consumption, energy production by PV plant, and value in euros) by the distribution operating

system for the “ATEARJO” company. The data shown in table IV underlines the average monthly energy consumption by the company as 111,470 kWh or 22,300 euros.

For the production of electricity, photovoltaic elements with a maximum power of 580 kW were installed on the rooftop of the building. Figure 2 shows some views of the installed elements. The panels used in the object are Q.PEAK DUO XL-G11.7 570-590. The photovoltaic plant consists of 1000 panels, obtaining a maximum power of 580 Wp. A string consists of 14–15 panels connected in series. For converting the energy produced by the solar panels (DC) into alternating current, five Fronius inverters with a rated power of 115 kW are used.



Figure 2: View of the inverters installed in the object.



Figure 3: Monthly energy production by photovoltaic plant.

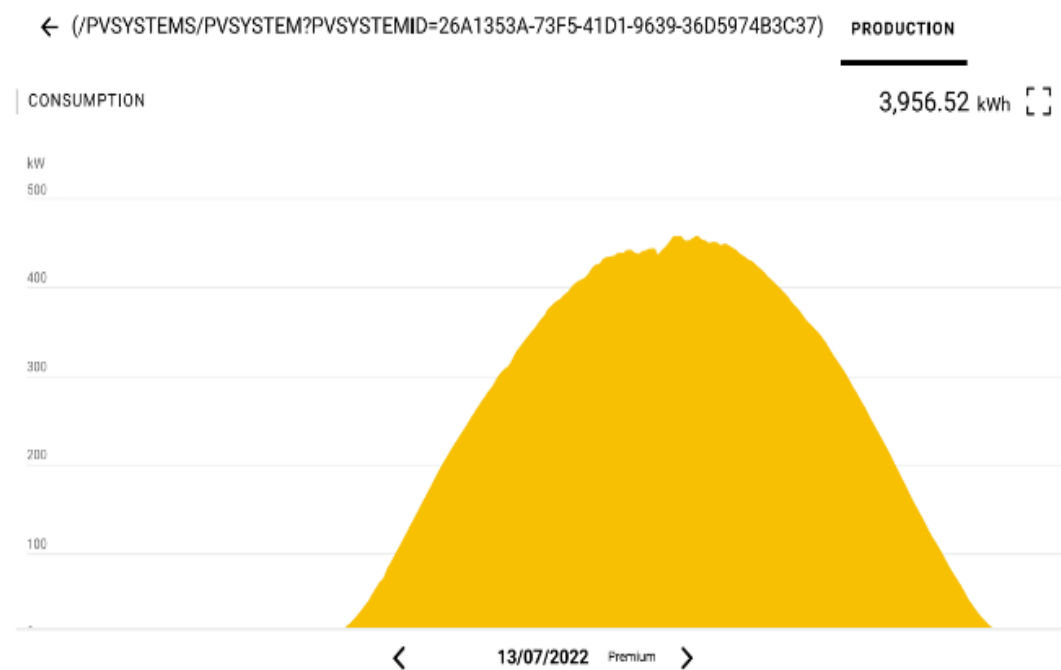

Figure 4: Electricity production by the solar panels on 13/07/2022.

Table 5: Monthly invoice by OSHEE of "ATEARJO" company.

Month	Energy consumption	Energy production by PV	energy billing [KWH]	Invoice value [Euro]
April	110,420	61,810	48,610	9,722
May	99,120	90,600	8,520	1,704
June	109,370	97,750	11,620	2,324
July	118,700	107,770	10,930	2,186
August	119,700	88,140	31,560	6,312
September	100,760	67,720	33,040	6,608

The photovoltaic plant is connected to the electrical system (on grid mode). The graph in Figure 3 shows the electricity production from photovoltaic panels during the period April–August 2022. Also, the graph in Figure 4, shows the electricity production by the solar panels on 13/07/2022. The results showed that the maximum value of energy production by the installed solar plant was 480-kilowatt hours. The total energy produced until September 17, 2022, results in 486,060 kWh.

Table 5 shows the electricity production by solar panels, energy consumption, and energy billing by OSHEE for the period from April until September 2022, when the photovoltaic elements are connected to the electrical system.

As seen from the data, it appears that electricity bills have decreased. The electricity produced by the photovoltaic system covers about 80 percent of the electricity consumption necessary for the company. It should be noted that the company operates 24 hours a day. The Albanian energy law so far does not affect the monthly energy balance. In case when the energy production by solar panels is more than the energy needed a part of energy production is injected into the net power grid. The solar energy penetrating into the system is not billed, so the company does not get benefit from the injection of energy into the system. Investment in the construction of solar panels is 350,000 euros. About 100,000 euros have been obtained for nearly 5 months in which the plant has been put into production. The progress so far results in the fact that in about 18 months the entire investment can be returned. With the change in the energy law, the benefits of the photovoltaic plant will be greater. As known photovoltaic elements do not produce electricity at night, the company is supplied by the distribution system. The energy

received by the company during peak hours is not included in the energy balance. This is the reason that the monthly electricity bill for the "ATEARO" company is not zero. The Albanian government is taking into consideration the suggestions from solar energy producers to make the annual energy balance.

4. Analysis of the impact of solar energy on the power system

The production of electricity using photovoltaic elements has significantly increased the efficient use of water resources in Albania. Also, the installation of photovoltaic elements has significantly reduced the import of electricity from abroad region. Nowadays, obtaining a license to build a power plant, such as a solar or eolic plant, is fraught with unnecessary red tape. If the energy market is liberalized, especially for photovoltaic elements, their impact on the energy sector will be significant. In fact, in recent years, licenses have been granted for the construction of several photovoltaic parks for the production of energy with a power rating of 2–100 MW. There are some problems in the power system with the increase of solar plants installed. The main problem encountered is the power quality (Mohamed A.E., Zhengming Zh., 2010). Except for the fundamental harmonic, the voltage and current spectrum of the inverter output contain high-order harmonics. Figure 5 shows the output of the voltage and current waveform of the inverter. The voltage and current waveforms as shown are distorted. Moreover, nonlinearities in addition to nonlinear loads can be introduced in the distribution grid by distributing harmonic sources such as non-sinusoidal waves at the output of solar PV inverters (Ahsan S. et al., 2021).

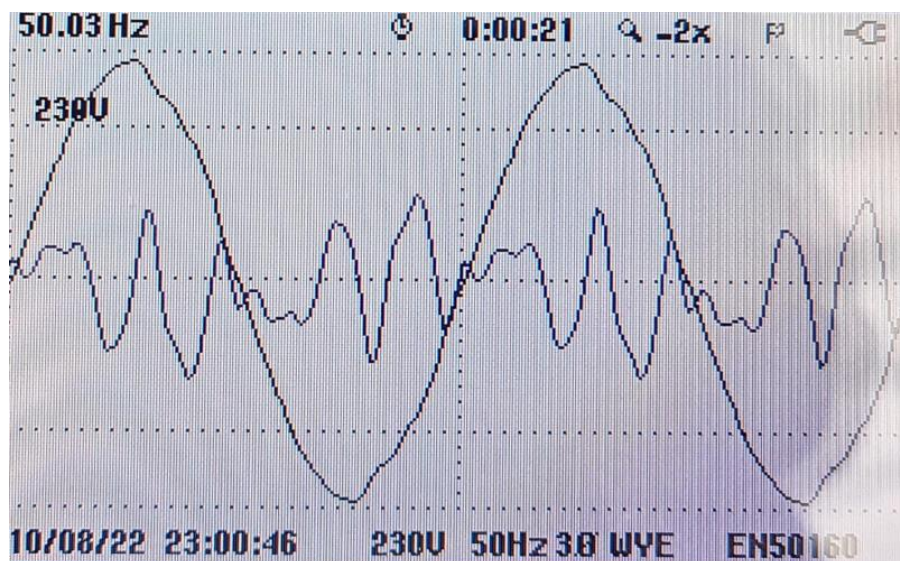

Figure 5: Voltage and current waveform of the inverter.

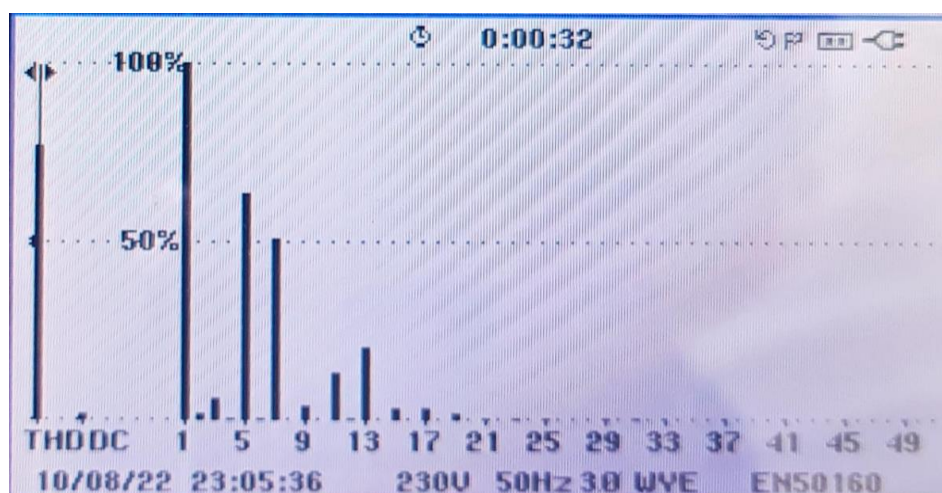

Figure 6: Current spectrum.

As it stands, generally, inverters need to come with high-quality switching, producing pure sinusoidal waves. However, mostly modified sine waves of current and voltage at the output of substandard inverters pollute the LV grid (Chidurala A. et al., 2014). Figure 6 shows the spectrum of the current. As shown by Figure 6 the 5th and 7th-order harmonics dominate the current spectrum.

The high-order harmonics orders of the voltage output inverter cause problems in the power system. In this way, measures should be taken to eliminate them by installing reactors in series (Zhang Y., et al., 2019).

Therefore, net metering prosumers must insert the required reactive power along with the active power into the grid (Sara E. et al., 2013). The transmission or distribution lines, in most

cases, do not support the injected energy production by solar panels. Therefore, in addition to the construction of photovoltaic plants, it should be taken into consideration for the construction of new substations, transmission, and distribution power lines. During the solar panel produces electricity the voltage level increase upper than the allowed value.

Figure 7 shows the voltage level at the power system node when solar plants are connected, e.g., the value of phase voltage is 270 volts at a certain time. this value is unacceptable for the electrical equipment. An increase in voltage level is associated with an increase in reactive power from the electrical system. In this case, reactive power compensation is necessary.

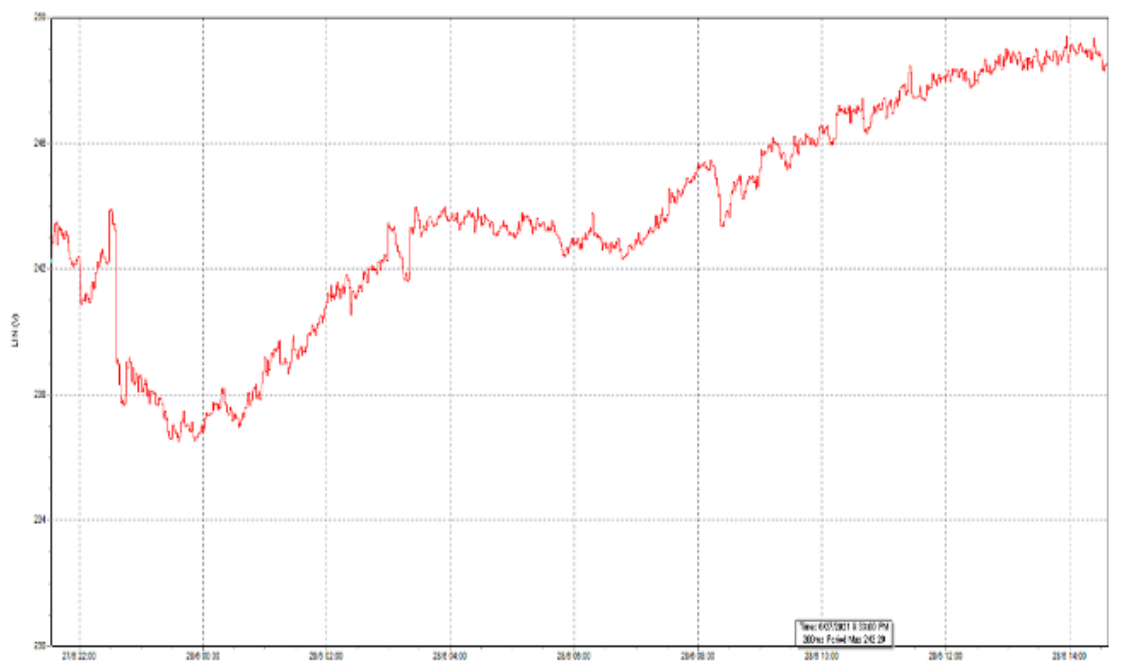

Figure 7: Phase voltage value during solar panel working.

Also, another problem of energy production with photovoltaic elements is the sudden change of energy due to climatic conditions. This causes a strain on the hydropower plants, which serve to balance the energy in the power system.

Since the production of electricity using photovoltaic elements is a renewable source, it affects the reduction of environmental pollution and the release of carbon dioxide. Until now, from the electricity production of the Atearjo company's photovoltaic plant, about 257.67 tons of carbon dioxide have been saved.

5. Conclusions

In conclusion, since Albania is considered a region with good solar radiation, it has the potential to produce energy through solar plants. Solar energy is a very promising source of energy for the future and it is an inexhaustible natural source of energy. Based on the analysis in the article, we reach the following conclusions:

- The energy from the sun is free and unlimited.
- Solar power is non-polluting.
- The production of electricity through photovoltaic plants would make possible the more efficient use of water resources in the country.

- Solar power usage does not emit any greenhouse gases or harmful waste.
- Solar power is perfect and saving for power generation in remote areas or where the cost of expansion of the utility grid is high.
- Solar panels, due to their simple construction and low maintenance cost, are mainly used for generation purposes.
- The electric distribution and transmission networks must take measures to facilitate the construction of new power lines and substations to inject energy into the system produced by the photovoltaic plants.
- The energy market should be liberalized, especially the granting of licenses for the installation of photovoltaic plants for residential and industrial applications.

Acknowledgment

The authors would like to thank the financial support from the “ATEARJO” Company where main activity is plastic recycling.

References

ERE, 2021, Annual Report. Available at: <https://www.ere.gov.al/en/publications/annual-reports>

Solar Power Europe, 2017, *Global market outlook for solar power, 2017–2021*. <https://resources.solarbusinesshub.com/solar-industry-reports/item/global-market-outlook-2017-2021>.

National Agency of Natural Resources (AKBN): www.akbn.gov.al

Sara E., Vijay V., Gerald H., Brian K., Jeffrey L., 2013, “*Impact of increased penetration of photovoltaic generation on power systems*”. IEEE Transactions on Power Systems (Volume: 28, Issue: 2).

Alirezai M., Noori M., & Tatari O., 2016. “*Getting to net zero energy building: Investigating the role of vehicle to home technology*”. *Energy and Buildings*, 130, 465–476. <https://doi.org/10.1016/j.enbuild.2016.08.044>

Mohamed A.E., Zhengming Zh., 2010, “*Grid-connected photovoltaic power systems: Technical and potential problems—A review*”. *Renewable and Sustainable Energy Reviews* (Volume 14, Issue 1).

Ahsan S. M., Khan H. A., Hussain A., Tariq S., Zaffar N. A., 2021. “*Harmonic Analysis of Grid-Connected Solar PV Systems with Nonlinear Household Loads in Low-Voltage Distribution Networks*” *Sustainability* 13, 3709. <https://doi.org/10.3390/su13073709>.

Chidurala A., Saha T.K., Mithulananthan N., Bansal R.C., 2014. “*Harmonic emissions in grid connected PV systems: A case study on a large-scale rooftop PV site*”. In *Proceedings of the 2014 IEEE PES General Meeting Conference & Exposition, National Harbor, MD, USA, 27–31 July*; pp. 1–5.

Zhang Y., Ma C., Lian J., Pang X., Qiao Y., Chaima E., 2019. “*Optimal photovoltaic capacity of large-scale hydro-photovoltaic complementary systems considering electricity delivery demand and reservoir characteristics*”. *Energy Convers. Manag.* 195, 597–608.

An innovative flexibility management and optimization framework for demand side aggregators

Mr. Konstantinos TSATSAKIS

R&D Manager

Dr. Efstratios PAPOUTSIS

Senior Researcher, Smart Rue, ICCS, NTUA

Dr. Angeliki Lydia Antonia SYRRI

Senior Researcher, Smart Rue, ICCS, NTUA

Contact details of corresponding author

Tel: + 357 2535 5585

E-mail: kostas@suite5.eu

Address: Alexandreias 2, Bridge Tower 3013, Limassol, Cyprus

Abstract

The new geopolitical conditions at EC level (backed by the very recent REPowerEU (European Commission, 2019) regulation as well as the vast spread of Renewable Energy Sources (RES) pose new, major challenges for the electricity networks in Europe. Solutions for the optimization of local energy systems are required, enabling direct integration with distributed generation and demand, enabling enhancement and optimal coordination of local flexibility resources. Such integrated solutions shall optimally combine distributed generation, demand, storage, electric vehicles and interconnections with heterogeneous local energy networks and introduce them into holistic optimization strategies to ensure operational and economic optimization of local energy systems. Optimal coordination of local energy sources is directly linked to maximum utilization of the flexibility (Tsatsakis K., Tsitsanis A., 2021) they can offer to support the operational stability of the grid and reinforce the economics of local energy systems through the avoidance of RES curtailment and the establishment of local flexibility markets. Taking into account the emerging need for coordinated optimization of the flexibility potential of the different types of controllable assets available in the electricity network, we propose a state-of-the-art methodology and a framework for the optimal utilization of flexibility on the basis of:

- Accurate extraction of the flexibility potential of the different types of flexible assets by applying data driven techniques that take into consideration the actual status of the flexible devices.
- Fine-grained intra-portfolio orchestration of local generation output, demand and storage (including novel solutions for P2G systems), to facilitate maximum RES integration into the grid, avoidance of curtailment as well as self-consumption optimization at regional/community level.
- State of the art flexibility source optimization towards offering aggregate flexibility service offerings via local flexibility markets to address the balancing and ancillary grid needs for the operational optimization of local, regional and national networks.

The main innovation of the proposed approach is the incorporation of actual and in real time data as retrieved from the physical assets as well as the application of state of the art, ML based optimization techniques for intra-portfolio optimization as well as participation in local flexibility markets. The proposed framework has been developed and deployed and now is under extensive testing at a first of a kind, mid-scale demo site in Xanthi, Greece. The preliminary results from the evaluation of the proposed framework will be presented in this paper.

Keywords: Flexibility management, Aggregators, Self-consumption, flexibility marketplace.

1. A data driven flexibility profiling framework for energy assets

In order to support the provision of a fine-grained tool for flexibility management and aggregation, the conceptual architecture of the ICT solution is presented in Figure 1. At the heart of the system, is the flexibility profiling layer responsible to incorporate the heterogeneous modelling approaches as different software bundles, setting that way the different microservices for the management of the different flexible assets' technologies in place, namely:

- DER profiling layer covering generation, battery and EV charging point assets;
- P2X profiling layer covering P2G and P2H solutions;
- Demand Side Flexibility profiling layer covering demand side assets.

In this section, the high-level modelling details for the key controllable assets examined are presented, namely demand side management assets, battery solutions, P2G systems modelling.

In the field of demand side, the modelling is focusing on DHW and HVAC systems as the heavy controllable loads within the building environment. The modelling details for the DHW systems are presented in (Tsatsakis K, Tsitsanis A., 2021). In brief, the modelling framework is dependent on the hot/cold water temperature conditions, the power consumption and the water flow (as the representation of the demand for hot water).

In addition, a detailed model for air-to-air HVAC systems is defined as part of the demand side flexibility framework. The model principles of a grey-box 1-order RC model is considered in order to capture the evolution of indoor temperature of building, supposing the thermal capacity C, and the equivalent thermal resistance R as physical related parameters of the models. Starting from heat balance modelling, we need to correlate the impact of the HVAC system and heat losses to indoor temperature conditions, as expressed in the following equation:

$$\frac{dT_{in}}{dt} = f(\dot{Q}_{in} - Q_{out}) \quad (1)$$

Where:

$\frac{dT_{in}}{dt}$, is the temperature different at each time step

\dot{Q}_{in} , is the thermal heat flow from the heat source (HVAC system)

Q_{out} , the heat loss in the building environment

Considering physics law dynamics, the variation of the indoor temperature is characterized by the difference between the variation of heat flow from electric heater and heat loss multiplied by the reference C factor.

$$\frac{dT_{in}}{dt} = \frac{1}{C} (\dot{Q}_{in} - Q_{out}) \quad (2)$$

On the other hand, \dot{Q}_{in} is defined by taking into account the COP of the heating/cooling system and the power characteristics, while the heat losses equivalent as the difference between the indoor and the outdoor temperature, divided by the equivalent thermal resistance of the building (R) as depicted in the following:

$$Q_{out} = \frac{T_{in} - T_{out}}{R} \quad (3)$$

Considering the discretization of the variation of the indoor temperature, the equation of the thermal building model is presented:

$$\frac{dT_{in}}{dt} = \frac{1}{C} \dot{Q}_{in}(t) - \frac{1}{C} \left(\frac{T_{in}(t) - T_{out}(t)}{R} \right) \quad (4)$$

$$T_{in}(t+1) = T_{in}(t) + \frac{1}{C} \dot{Q}_{in}(t) dt - \frac{1}{C} \left(\frac{T_{in}(t) - T_{out}(t)}{R} \right) dt \quad (5)$$

Overall, the RC modelling equation consists of the definition of the relationship between indoor, outdoor temperature conditions and the operation of the HVAC system. In order to extract the R, C parameters, a simple statistical method applies (fitting regression approach) is considered. In Figure 2, the raw data about indoor/outdoor conditions and the impact of HVAC operation is provided. In Figure 3 the model vs actual conditions of the HVAC system are presented over the time (3-week period). The battery system is modelled using Kinetic Battery Model which is an intuitive battery model originally developed to model the chemical processes of large lead-acid batteries

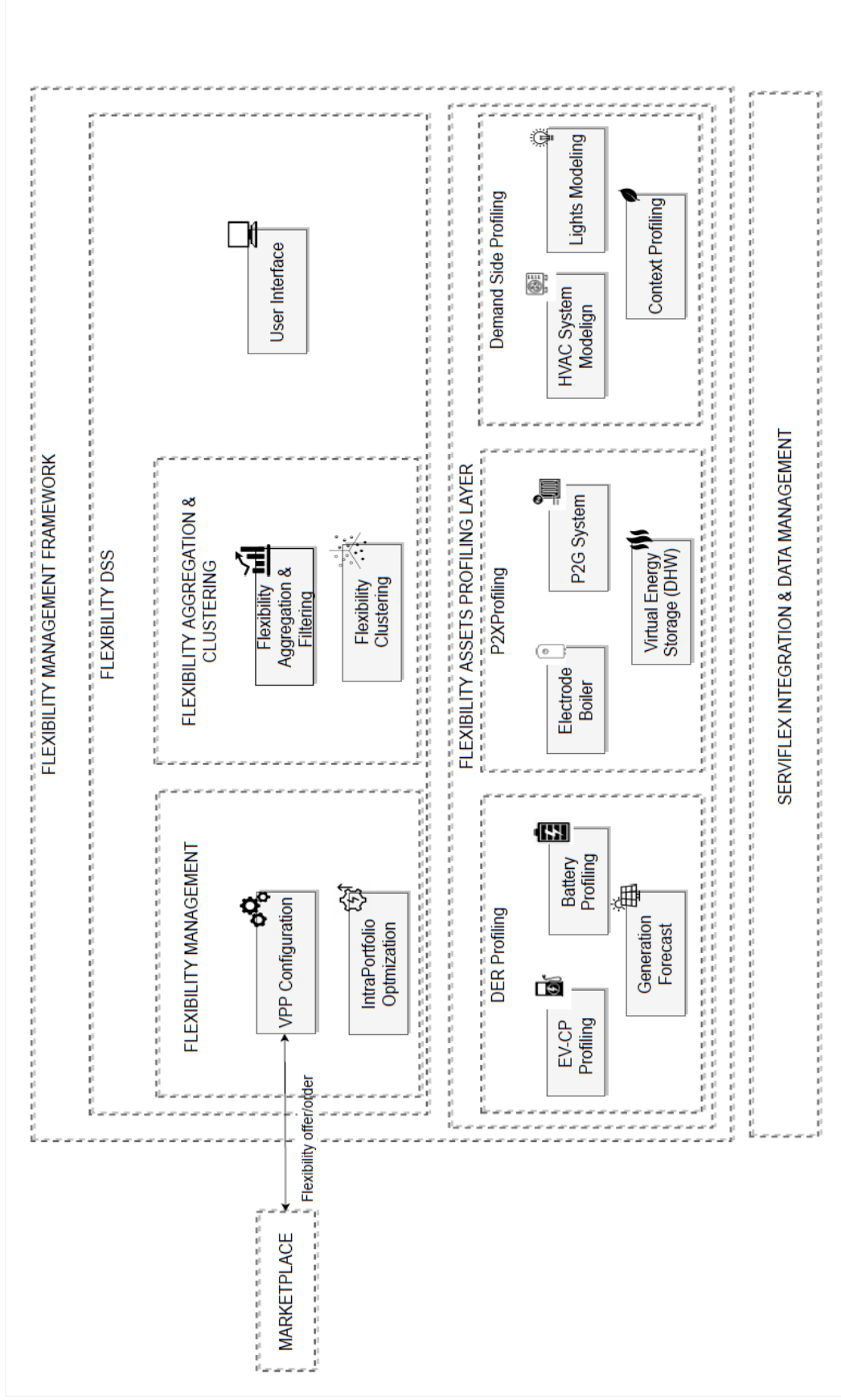

Figure 1: Flexibility Management Tool Conceptual Architecture.

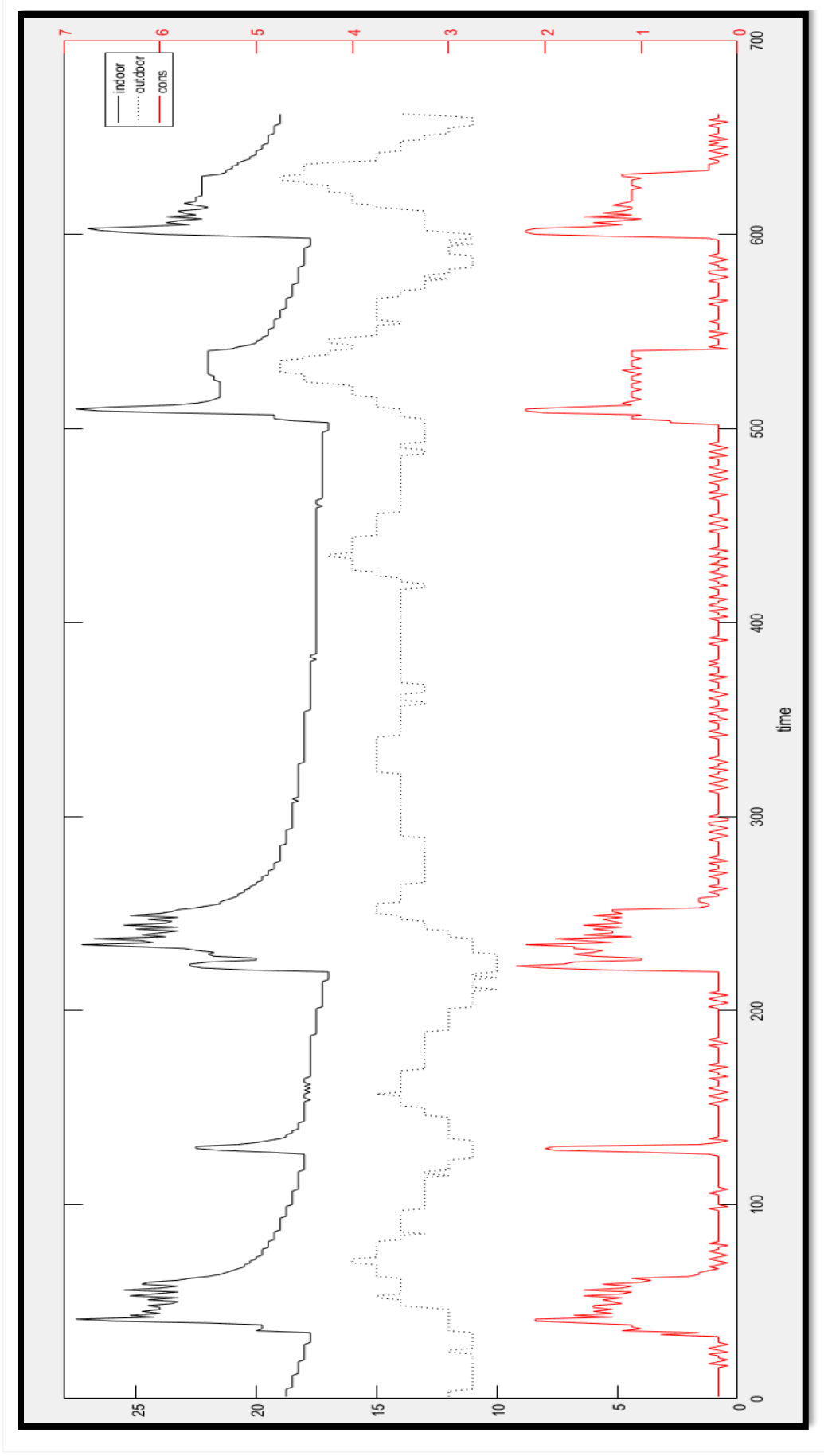

Figure 2: HVAC operational conditions.

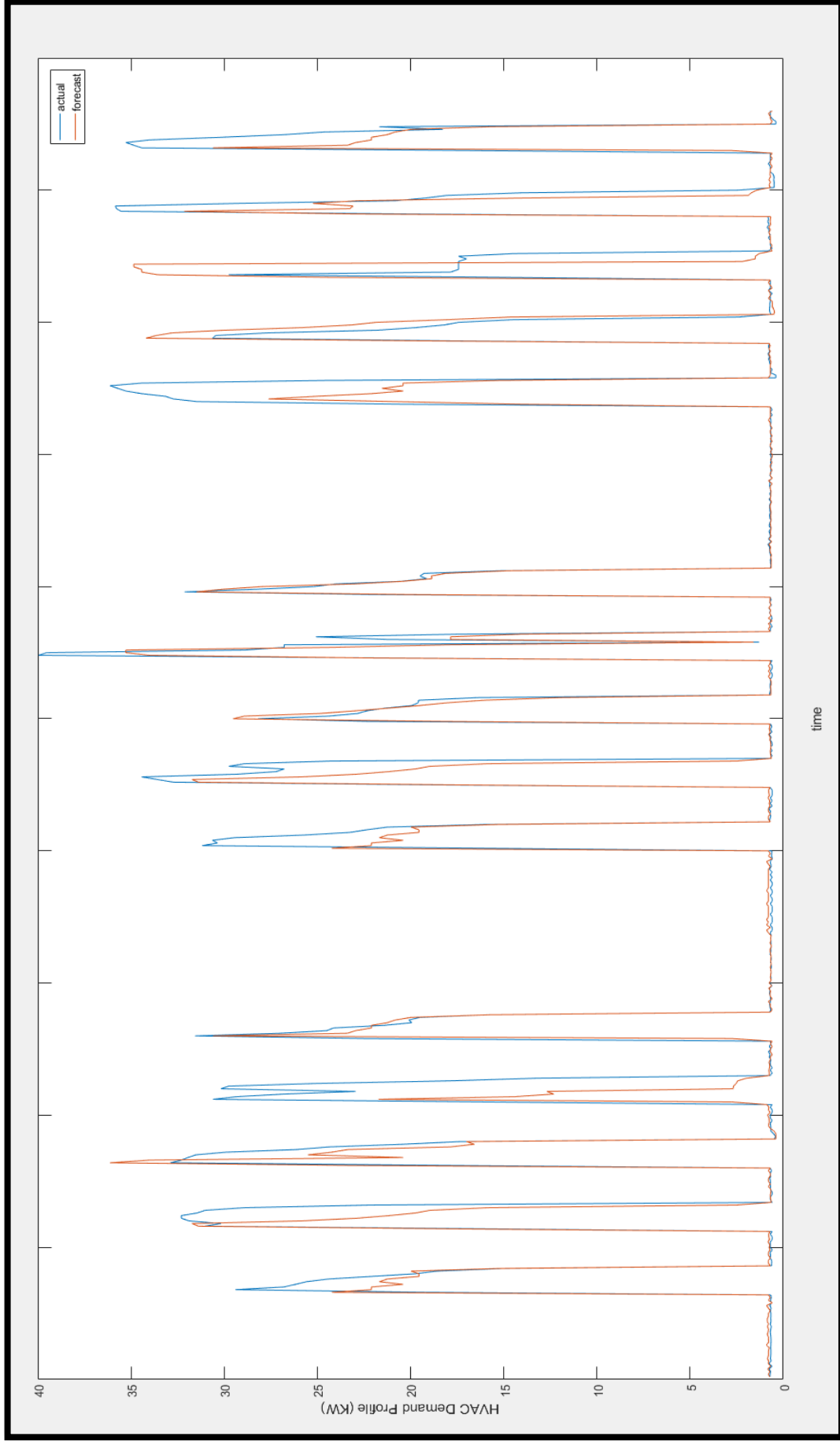

Figure 3: HVAC Energy Consumption Modelling.

by a kinetic process (Manwell JF., McGowan JG., 1993). The main equations of the KiBaM are presented below:

$$q_1 = q_{1,0} \cdot e^{-k \cdot t} + \frac{(q_0 \cdot k \cdot c - I) \cdot (1 - e^{-k \cdot t})}{k} - \frac{I \cdot c \cdot (k \cdot t - 1 + e^{-k \cdot t})}{k} \quad (6)$$

$$q_2 = q_{2,0} \cdot e^{-k \cdot t} + q_0 \cdot (1 - c) \cdot (1 - e^{-k \cdot t}) - \frac{I \cdot c \cdot (k \cdot t - 1 + e^{-k \cdot t})}{k} \quad (7)$$

Where

q_1 is the “directly available capacity”,

q_2 is the “temporary capacity” of the battery,

c is the fraction of the capacity stored in the available charge tank,

k is the rate constant,

I is the current and t is the time.

A comparison between simulated and experimental results is presented in Figure 4. Regarding the P2G system empirical models have been adopted for both the electrolyzer and the fuel cell. The respective equations are presented below. Current-voltage characteristic of the electrolyzer (Ulleberg Ø., 2003):

$$U = U_{rev} + \frac{r_1 + r_2 \cdot T}{A} \cdot I + (s_1 + s_2 \cdot T + s_3 \cdot T^2) \cdot \log\left(\frac{t_1 + t_2/T + t_3/T^2}{A} \cdot I + 1\right) \quad (8)$$

Where

U_{rev} is the reversible cell voltage,

r_i ($i=1..2$) are parameters for ohmic resistance of electrolyte,

s_i, t_i ($i=1..3$) are parameters for overvoltage on electrodes,

A is the area of the electrode and

T_{el} is the temperature of electrolyte.

Current-voltage characteristic of the fuel cell (Ulleberg O., 1998):

$$U = U_0 - b \cdot \log(i) - R \cdot i - m \cdot \exp(d \cdot i) \quad (9)$$

Where

U_0 is the open circuit voltage of the fuel cell,

b is the Tafel slope of the fuel cell,

R is the resistance of the fuel cell,

m and d are the parameters for overpotential due to mass-transport limitation.

In Figure 5, a comparison between experimental and simulated results is presented.

2. Flexibility management and optimization framework management

On top of the flexibility profiling layer presented in previous section, a state-of-the-art analytics layer is incorporated in the ICT solution to enable the provision of fine-grained services to the business actors. There are four different types of analytics features supported by the application, namely:

- Flexibility Aggregation & Filtering Module to enable search over the flexible assets available at the portfolio of the aggregator and further aggregation of flexibility profiling data (from the flexibility sources) in order to address the business needs of the aggregator.
- Flexibility Clustering module to provide fine grained analytics techniques for the management of the flexibility sources available in the portfolio of the aggregator.
- VPP Configuration module to facilitate the optimal placement of the flexibility sources to 3rd party business campaigns. These business campaigns are triggered by the market as the innovative flexibility marketplaces are evolving now in Europe.
- Intra portfolio optimization module to facilitate the optimal management of the flexibility sources within the portfolio of the business stakeholder of the tool.

The first layer is the Flexibility Aggregation & Filtering module is providing the functionality of searching over the portfolio of the aggregator and filtering with specific criteria in order to set groups of flexibility assets with similar characteristics. There are different parameters (both technical and business) that characterize the flexibility assets and on the basis of these parameters appropriate segments may be defined in order to set groups of flexible assets which are of interest for the business stakeholder (Aggregator).

On top of this filtering functionality, an aggregation functionality is incorporated in order to aggregate energy and flexibility related profiling information, which is again of interest for the business processes of the business stakeholder. Filtering functionality over the data streams is also incorporated in order to enable search over a selected period of time. The flexibility clustering module is responsible

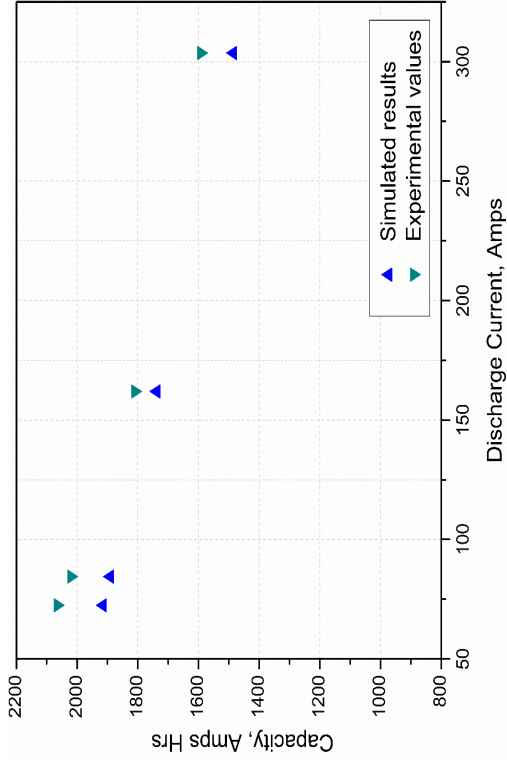

Figure 4: Comparison between simulation results and experimental data for the Sunlight battery system.

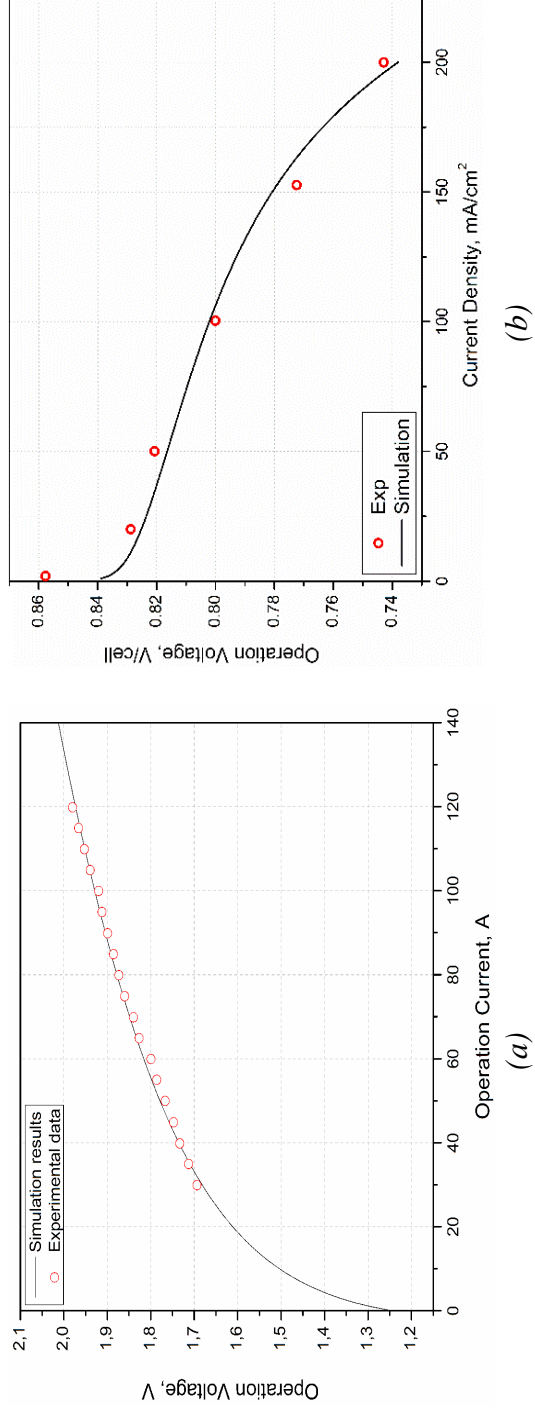

Figure 5: Comparison between simulated and experimental values for the P2G system, (a) electrolyzer, (b) fuel cell.

for the execution of simple and advanced analytics processes over the flexibility data streams.: More specifically, the module complements the filtering functionality as presented above and support the quick access to the filtered data, as well as the execution of the respective analytics services generic statistics algorithms (i.e. aggregations, KPI calculations etc...) as well as advanced models (i.e. ML-based algorithms such as classification, clustering, regression, etc. targeting the energy domain applications) are incorporated in the module in order to serve the clustering scenarios of interest for the business actors.

While the filtering and clustering analysis is focusing mainly at the provision of insights for the business actors, there are different optimization strategies and scenarios incorporated in the ICT tool to serve the business needs for flexibility exploitation. At first, the VPP Configuration Layer module is responsible for the execution of the optimization of the portfolio flexible assets taking into account 3rd party requests triggered by the flexibility markets. There are different approaches adopted in the market, with the most common approach to be defined by USEF as the state-of-the-art implementation for flexibility exchange through a market-based framework. Under this concept, the overall management of flexibility is performed taking into account:

- The flexibility potential at portfolio (aggregation) level as well as the flexibility request that has been made available from the flexibility markets via a bid that has been triggered to the tool. The bid contains information about the amount of flexibility to be served over a specific timestep.
- The pricing/market details about the usage of the different flexibility sources that are part of the portfolio. We have to point out that these market details are incorporated in a flexibility registry in order to promptly remunerate the different flexibility sources for the provision of the associated flexibility
- The level of reliability of each flexible source that is part of the portfolio of the Aggregator.

Then, a linear optimization process applies in order to formulate the subset of the aggregator portfolio that will execute the demand response

signal. The details of this optimization process are provided below:

$$\min \sum_{i=1}^n S(\text{flex}_i), \quad (10)$$

$$S(\text{flex}_i) = f(\text{price}, \text{reliability}) \cdot |\text{flex}_i|$$

$$|\sum_{i=1}^n \text{flex}_i| = |\text{FlexOrder}|$$

$$|\text{flex}_i| \leq |\text{FlexOffer}_i|, i = 1, \dots, n$$

$$|S_n(\text{flex}_i)| \leq |S_n_limit_i|, i = 1, \dots, n$$

Where:

- flex_i is the flexibility utilisation of each flexible asset that is part of the portfolio of the aggregator
- $f(\text{price}, \text{reliability})$ as the cost incurred to the aggregator for utilizing the flexibility unit of the asset. As reported above, the cost is defined as a synthesis of financial and performance related parameters. In the context of experimentation, we consider a linear proportional correlation of the price with the cost and a negative slope for reliability level in order to quantify the penalization for non-reliability at flexibility provision.
- FlexOrder as the total flexibility requested by external markets. This is the typical case of DSO requests for flexibility in order to address grid needs.
- FlexOffer_i as the maximum amount of flexibility estimated to be available by each flexibility asset.
- $S_n(\text{flex}_i)$ any other limitation imposed at the provision of flexibility. For example, it may be the case that the total amount of flexibility to be offered by an asset should not exceed a specific amount over a period of time (these are typical contractual limitations that are defined in bilateral contracts between aggregators and flexibility asset owners).

In parallel to the formulation of the portfolio for DR activation, a backup list is formulated with the remaining flexibility resources and amounts that are available for the same interval but are excluded from initial enrolment. In case, there is no fulfilment of activation from the main pool, the procedure of VPP restructuring is performed in order to reset the portfolio for activation. The output format (for asset flexibility activation) is following the

USEF/UFTP principles (a simplified approach incorporating only the mandatory fields), providing the details about the activation of each asset for each time interval.

Following the execution of any DR campaign, the VPP Configuration module is responsible for the calculation of the flexibility related KPIs; results intended to be available to the business stakeholder through a dedicated UI.

Complementary to the VPP Configuration module, the intra-portfolio optimization module is responsible for the execution of the optimization of the portfolio assets taking into account intra-portfolio business objectives (thus not participating in flexibility related markets). More specifically, this module incorporates the optimization algorithms for assets management addressing both cost minimization as well as self-consumption optimization use cases. The details of the optimization process are presented below.

$$\min/\max_{OperationalCost, Self - Consumption} \quad (11)$$

Energy Balance Equation

$$|SoC, \min| < |SoC_i| < |SoC, \max|, i = 1, \dots, n$$

$$|P_i| < |P, \max|, i = 1, \dots, n$$

$$|flex_i| \leq |flexOffer|, i = 1, \dots, n$$

The details of the different methods (11) are then provided; at first the functional objective details are specified. As stated in the intro section, there are 2 core business objectives for the flexible asset manager: to minimize operational/energy costs or to maximize the level of self-consumption |(thus minimizing the dependence on the upstream network:

OperationalCost:

$$\min \sum_{n=1}^N \sum_{t=1}^T (E_{n,t} * S_{n,t}),$$

$E_{n,t}$: energy from n source at time t

$S_{n,t}$: energy cost of n source at time t.

The cost data refer to the cost for energy generation from the different DERs or the price of the market for injection of energy from the grid.

$$Self - Consumption: \min \sum_{t=1}^T E_{grid}$$

E_{grid} : energy from the grid at time t

Apart from the core business objectives, the constraints of the optimization process are defined. At first the *Energy Balance Equation*, express the equilibrium between generation and consumption at local level (also the energy balance from/to the storage systems available at the demo site), considering the different types of assets (generation, storage, demand) available at the demo site ($E_{demand} = E_{localgen} + E_{storage} + E_{grid}$).

In addition to the energy equilibrium, constrains at asset level are also considered in the analysis and more specifically:

- *SoC*, the state of charge level of the different storage systems available on site should be within the operational limits of the storage system,
- *P*, the power charge/discharge potential of the different systems available on site should be within the operational limits. This is again very important for the battery systems where operational limits apply,
- *flex*, is the flexibility utilisation for each flexible asset.

Based on the optimization result, the control strategies to be performed in order to achieve the goal objective are formulated. These are expressed either as flexibility schedules for the flexible assets (demand side) or as power schedules for the storage related assets. In addition, the module is responsible for the calculation of the intra-portfolio performance KPIs; similar to the VPP Configuration module presented above.

We presented above in brief the technical details about the different analytics processes that are executed at the DSS layer of the tool. This is a mixture of data analytics techniques incorporated in order to provide a fine-grained analysis of the flexibility potential and optimization processes in order to maximize the level of exploitation of the different flexible sources that are part of the portfolio of the aggregator.

3. Flexibility Assessment demonstration activities at the Greek demo site

The overall solution is about to be tested for a long period of time (18 months) in real conditions in 4 pilot sites in 3 EU Member states (Bulgaria, Slovenia and Greece), with different needs and socioeconomic and technological boundaries, involving multiple existing flexibility assets (batteries, power to heat/cold, vehicle to grid and other storage solutions) and all complementary actors of the energy network (DSO, microgrid operator, utilities, flexibility providers, local communities). In this section, the focus is at the presentation of the results from the early demonstration activities at a Greek site in Xanthi region. A whole set up has been established with the integration of local generation, flexible demand, battery systems and P2G technologies. In the following figure, the schematic of the demo site is presented.

The focus of the optimization is the maximization of self-consumption. The base curves for local generation are presented. Then, by taking into account the flexible profile as well as the capacity of the storage systems in place, the optimization process applies.

In figure 7, the aggregate daily data of the different sources over a short period of time (2-week period) are presented. It is worth referring to the dynamic operation of the storage systems as they can charge and discharge based on generation and demand data.

A snapshot of the operation of a single day is presented in figure 8. From the analysis it is evident the sequential operation of the different systems. First charging the battery system (in case generation > demand), then charge of the P2G system (by utilizing also load from battery in order to address the technical limitations of the electrolyzer) and then the rest of excess is exported to the grid.

4. Conclusions

The main objective of this document is to specify the modelling details of an innovative ICT tool that will facilitate the management of local flexibility profiles in order to forecast and decide upon optimal flexibility utilization strategies, while satisfying the goal of reduced complexity that comes from organising profiles into clusters of homogeneous behaviour.

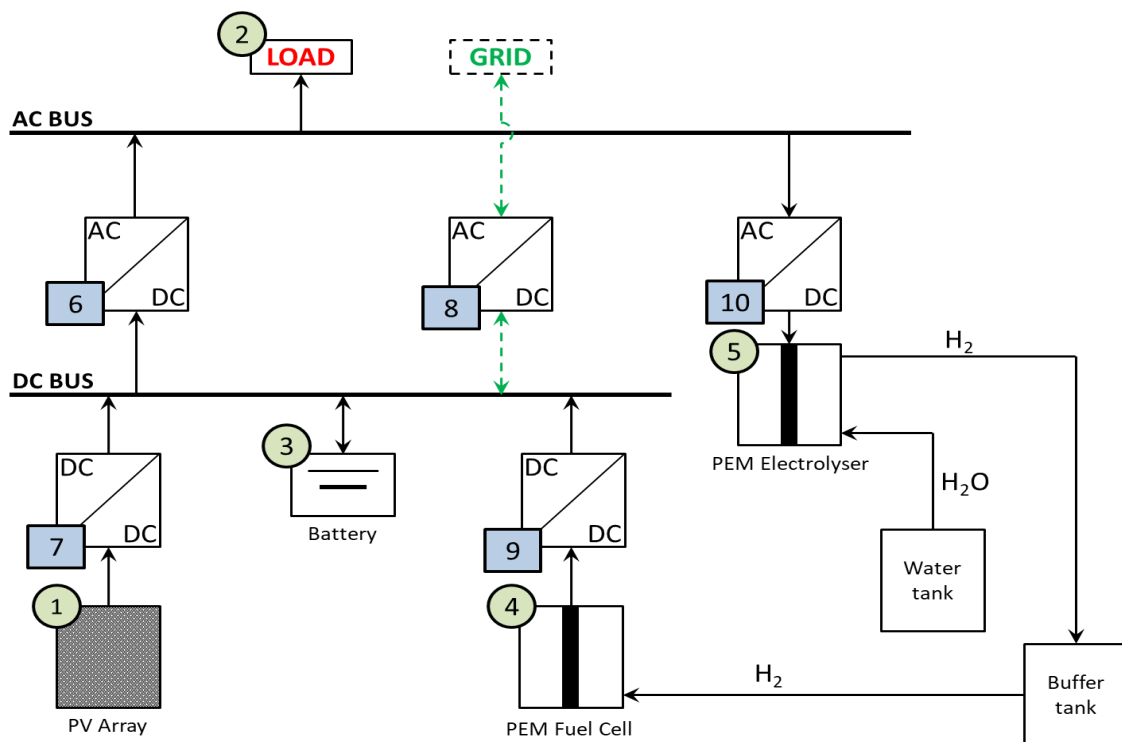

Figure 6: Microgrid set up in Greece.

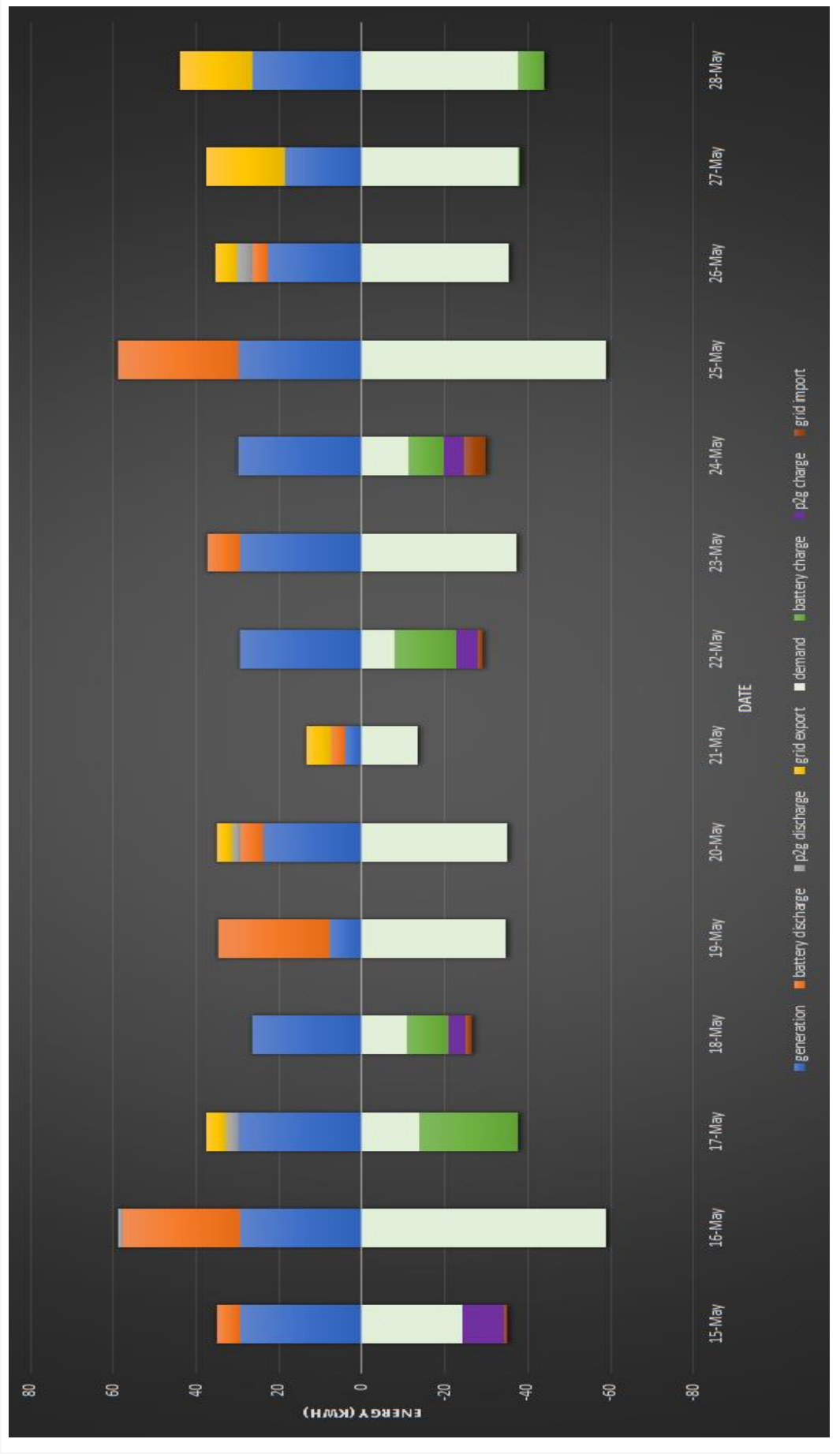

Figure 7: Self consumption optimization over a 2-week period.

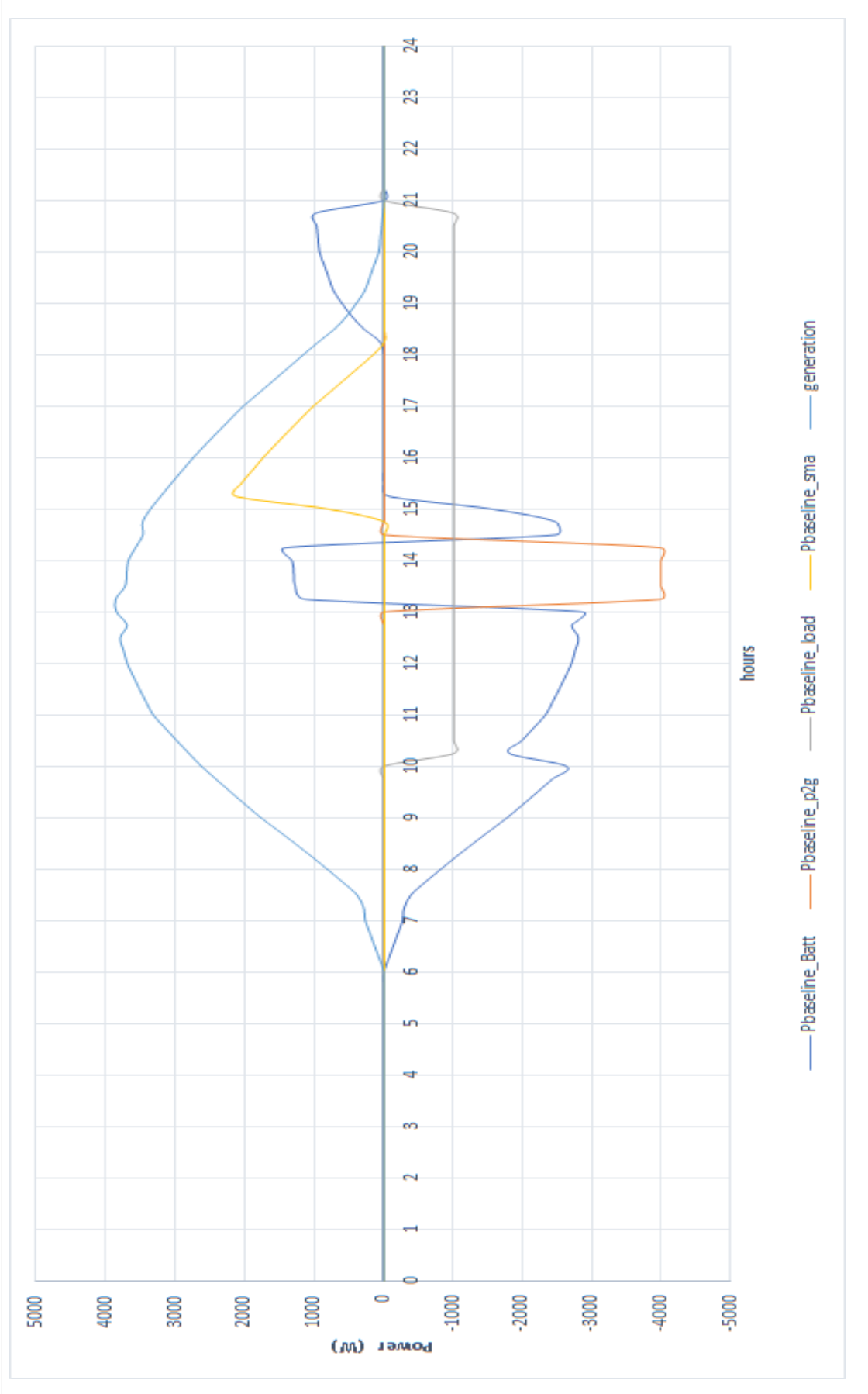

Figure 8: Self consumption optimization over a typical day.

The tool embeds all functionalities pertaining to the tool chain for collecting local flexibility profiles, managing them in order to establish optimal VPP composition for the delivery of flexibility services to network

operators or the market. An extensive testing has already been performed in the Xanthi demo site and this will continue together with the replication of the demonstration activities in 2 other demo areas of Europe.

Acknowledgment

The work presented in this paper is co-funded by the EU HORIZON 2020 Program (topic: “LC-SC3-ES-1-2019 - Flexibility and retail market options for the distribution grid”) under grant agreement no. 863927 (project title: “XFLEX - Integrated energy solutions and new market mechanisms for an extended Flexibility of the European grid”, <http://xflexproject.eu/>).

Abbreviations

V2G	Vehicle to Grid
EU	European Union
P2X	Power-to-X
P2G	Power-to-Gas
P2H	Power-to-Heat
VPP	Virtual Power Plant
RES	Renewable Energy Source
DHW	Domestic Hot Water
DSM	Demand Side Management
PEM	Polymer Electrolyte Membrane
SCADA	Supervisory Control and Data Acquisition
UI	User Interface
HVAC	heating Ventilation Air Condition
DSO	Distribution System Operator
DA	Day Ahead
ID	Intra Day
GHG	Greenhouse gas
UC	Use Case
DER	Distributed Energy Resources
EVs	Electric Vehicles
KPIs	Key Performance Indicators

References

- European Commission, 2019. “Clean energy for all Europeans,” Luxembourg, 2019.
- European Commission, “EU Green Deal” https://ec.europa.eu/info/strategy/priorities-2019-2024/european-green-deal_en
- Manwell JF., McGowan JG., 1003. “Lead acid battery storage model for hybrid energy systems,” Solar Energy, vol. 50, no. 5, pp. 399-405, 1993.
- Tsatsakis Konstantinos, Tsitsanis Alexandros, 2021. A holistic flexibility management framework for energy aggregators, 14th International Scientific Conference on Energy and Climate Change
- Ulleberg Ø., 2003. “Modelling of advanced alkaline electrolyzers: a system simulation approach,” International Journal of Hydrogen Energy, vol. 28, no. 1, pp. 21-33, 2003.
- Ulleberg O., 1998, “Stand-alone power systems for the future: Optimal design, operation & control of solar-hydrogen energy systems”, Ph.D. dissertation, Norwegian University of Science and Technology Trondheim, Norway, 1998.

Education and Citizen engagement as drivers for ecological transition: the GreenSCENT project

Prof. Maria Amata GARITO¹

Professor Emeritus of Psychotechnologies, Rector and President – Università Telematica Internazionale UNINETTUNO

Dr. Alessandro CAFORIO

Director of Research and Innovation – Università Telematica Internazionale UNINETTUNO

¹*Contact*

Università Telematica Internazionale UNINETTUNO

Tel: +390669207628

e-mail: garito@uninettunouniversity.net

Address: Corso Vittorio Emanuele II, 39 – 00186 – Rome, Italy

Abstract

While climate change and environmental degradation are already causing a higher frequency of extreme weather events, worldwide temperature increases, and climatic instability, citizenship hardly recognizes climate change and environment-related issues as main challenges for the next decades. Recent studies suggest that the majority of the citizens does not consider Climate and Environmental diseases among the most serious problems. On the other hand, communication, information, awareness and education are seen as key strategies for engaging people in understanding the challenges humanity and planet Earth are facing, and acting positively and appropriately.

GreenSCENT (<https://www.green-scent.eu/>) is a project funded under Horizon 2020 European Commission framework program for Research and Innovation. Its main objective is to support EU Green Deal policy implementation involving EU citizens, and especially youth, in co-creating, experimenting and validating a Multidisciplinary European Competence Framework (GreenComp) covering the main thematic areas of the EU Green Deal. GreenComp will be developed in a lifelong learning perspective, covering educational levels from primary schools to Higher education and continuous professional development, through a participatory multi-stakeholder approach engaging young students, teachers and finally citizens from all schools and educational institutions in Europe.

The first section of the proposed work presents GreenSCENT project's motivations, objectives and pillars. The second section of this paper provides details about the project methodology, while section 3 will present the activities in the first Phase of the project. Conclusions focuses on the foreseen challenges in the development and validation of digital and hybrid tools, educational activities and frameworks enabling EU citizen to embrace the new EU Green Deal.

Keywords: Ecological transition, Green Deal, Sustainability, Green Education.

1. Introduction

Climate change and environmental degradation are already causing dramatic sea level rise, a higher frequency of extreme weather events, worldwide temperature increases, unprecedented rates of carbon dioxide, methane and nitrous oxide in the atmosphere, and climatic instability (IPCC, 2018). These changes may disrupt societal functioning through increasing global migration, conflict, and disease, while endangering worldwide food systems (Burrows and Patrick, 2016; Gregory et al., 2005; Haines et al., 2006). Nevertheless, EU Citizenship hardly recognizes climate change and environment-related issues as main challenges and issues for the next decades. In most EU countries, Climate and Environmental diseases are not considered among the most serious problems by the majority of the citizens (Eurobarometer, 2009).

Several mechanisms fostering scepticism in climate change and its anthropocentric nature were already categorized by different studies. Communication, information, awareness and education are seen as key strategies for engaging people in understanding the challenges humanity and planet Earth are facing, and acting positively and appropriately (Santos and Feygina, 2017).

Furthermore, policy decisions and approaches are perceived as “remote” and threatening for the day by day lives of the population, their habits, their economic stability, and their jobs. Engaging citizens to care for their environment is one of the most challenging tasks nowadays. Europe is no exception and has to find different approaches to tackle environmental nurturing matching the wealth of EU cultures, languages, and citizen diversity.

Successful understanding of the many variables that impact climate, and how they can be modified by human behaviour, would lead to a multidisciplinary action. This in turn would require ingenious and clever engaging approaches to fit a wide spectrum of people profiles, all living in the EU 21 century Information Society. We need to engage people, allowing them to feel as a crucial actor in the changes needed, understanding why they are needed, and to reach them emotionally. Empathy is a key aspect for finding solutions to social and global problems.

EU Green Deal designs an ambitious plan that will impact EU citizens and organizations in the next few years. A successful implementation needs an active involvement of citizenship and stakeholders, aiming at increasing knowledge, awareness and competences in the main focus areas of the Green Deal, ranging from climate to food to pollution, mobility, construction and ecosystems. As stated by the Green Deal communication, young EU citizens are seen as potential ambassadors of this knowledge, that will impact on actual behaviour of themselves, their peers, parents, contacts, and educational institutions (from primary schools to universities) as key enablers for knowledge transfer and experimentation.

2. GreenSCENT project

For these reasons, International Telematic University UNINETTUNO together with a European-wide partnership for developing a research and innovation project, GreenSCENT – Smart Citizen Education for a Green Future – addressing the challenges regarding the social awareness and acceptance of the ecological transition.

GreenSCENT involves 15 partners from 10 European countries (Italy, Germany, Spain, Finland, Denmark, Austria, Serbia, Romania, France and Greece), including 5 Research/University partners, 1 Foundation, 4 Schools partners, 4 Small/Medium Enterprises and 1 Large ICT Company. GreenSCENT is funded by the Horizon 2020 research and innovation program of the European Commission, under the Green Deal call GD10.3, with contract number 101036480, started in January 2022 and will last for three years.

The project’s main objective is to support the New European Green Deal policy implementation involving EU citizens, and especially youth, in co-creating, experimenting and validating a Multidisciplinary European Competence Framework covering the main thematic areas of the EU Green Deal, fostering its acceptance and adoption with a participatory multi-stakeholder approach, and measuring its efficacy in terms of awareness, competences and implicit attitudes, key factors for a real behavioural change.

A Climate and Environmental Competence Framework for citizens, such as the one GreenSCENT aims to produce, will therefore be a crucial tool for developing the capacity to analyse and understand global and interdisciplinary issues as the ones addressed by the EU Green Deal. More than the tool itself, in order to maximize its acceptance and adoption among European citizenship and stakeholders, the design and validation processes needed to be carefully planned. Specifically, GreenSCENT is based on a set of pillars guiding its design and implementation:

1. Citizen engagement is a driver for change

Research demonstrates that, when directly and actively involved, citizens feel that the innovations are created with them and not for them, and when there is a lack of acceptance among citizens for such services, it becomes easier to ensure that they gain broad consensus (Bason, 2010).

GreenSCENT follows a user-centric approach; this will lead to a diverse and encompassing resilient solution in each step of its Competence Framework development: raising awareness, learning, assessment, and dissemination to all EU citizens.

2. Active experimentation will lead to better understanding and adoption

Increase of the citizen engagement, moving from simple information transmission or traditional education, to content manipulation, active observation, data collection and processing, and open innovation provides concrete, hands-on actions that individuals can undertake, thereby fostering feelings of involvement and engagement in helping address these problems. GreenSCENT “demonstrators”, hybrid and digital technologies and activities designed by the project consortium, help putting in practice the proposed competence framework and challenging students and citizens to “play” with science and with their behaviour, increasing the actual individual awareness of their day by day environmental footprint.

3. European Youths are crucial for addressing climate and environmental challenges.

Young EU citizens represent both the future of the European Union, and the more effective amplifier we have for spreading knowledge and information about the Green Deal and the need

for changes in behaviour. They can reach and involve both their colleagues in school, their peers outside the schools and their parents and families, as well as they can become professionals able to change the work market and the industrial, social, political processes in a green perspective for the protection of the planet. For the same reason, schools, universities, and educational institutions in general play a key role in this process.

4. Vulnerable groups must be involved and taken into consideration in this process.

Migrants, refugees, people with disabilities, the elderly, and people in rural areas, have to be included in the dialogue and concrete actions of the Green Deal. Europe can't afford to leave out these people since one of the main European trains is the “united in diversity”. The respect for the “other”, the inclusion and democratic participation of all citizens is one of the most important EU features, and SCENT will secure these. GreenSCENT will both involve different user groups in designing and validating the proposed solutions, and adopt accessibility standards and cross-cultural approaches in developing any of the analogic and digital demonstrators supporting the GreenComp.

5. GreenSCENT competence framework must be both acceptable and adoptable.

GreenSCENT aims at integrating existing good practices at EU level that will be used for validating the competence framework, together with Training Kits, Skill Cards and Demonstrators specifically designed for the project. Moreover, GreenSCENT will propose a European Certification for Climate and Environmental Literacy – inspired by the ECDL/ICDL models– helping other institutions and enterprises adopting the framework both for implementing training activities and for measuring the competence level of candidates and employees.

6. Competences needed go beyond climate and environment.

The activities proposed by GreenSCENT for testing and validating the Framework will ask citizens and especially students to develop competences, not just about climate or sustainability: they will be challenged in science education and scientific research foundations; in digital competences, and soft skills like creative thinking, problem-solving, team working, project planning and design.

Those transversal and complementary competencies will produce a positive effect on both their life and professional capacities, and in understanding the climate and environmental challenges.

3. GreenSCENT methodology

GreenSCENT is structured in 3 main phases; Phase 1 will lead to the 1st release of the competence framework; Phase 2 will produce, and pilot different demonstrators and initiatives covering the Green Deal focus areas competences, engaging different target users in different contexts, and will produce feedback for the revision and extension of the competence framework. Phase 3 will finalize the GreenComp, develop a European Certification on Climate and Environmental Literacy (ECCEL) designed based on ICDL–International Certification of Digital Literacy (former ECDL), and provide policy recommendations.

In its initial project phase, lasting one year, the main objective is to produce a first draft of the Competence Framework that will be further tested and validated in the next phase. The drafting will be based on several activities: the analysis of existing Climate/Environment-related Competence Frameworks for integrating the main findings and good practices already existing and in place; the further elaboration and categorization of competences based on the 8 main focus areas identified, starting from the EU Green Deal communication; the involvement of external advisors – selected from experts, researchers and activists, that will share their views and inputs for enriching the 1st competence framework draft; and a first iteration of Citizen Engagement initiatives, run in the pilot countries identified in the proposal, that will help integrating citizens' voices since the very early stage of the project.

In its core phase, GreenSCENT will test the first release of its competence framework against its final users: citizens, youth and students at different school levels. This will be done through piloting the demonstrator activities in the main Pilot sites identified: Rome (Italy), Barcelona (Spain), Helsinki (Finland), Novi Sad (Serbia), Copenhagen (Denmark), Kluz-Napoka (Romania). The activities considered have different “involvement” levels, ranging from pure

awareness raising to observation to active data collection and processing. To ensure that the competence framework is tested regarding all Green Deal topics in multiple contexts, the project has created a matrix with the Green Deal Focus Areas, the key actors targeted and the different levels of engagement and participation to ensure that the piloted activities complement each other. In this way, citizenship and youth will be informed and trained about all the 8 focus areas where citizen choices and behaviours can impact directly in a more perceivable way. Training, experimentation and engagement activities will both produce awareness and engagement among citizenship and students, and at the same time will provide feedback about the completeness and effectiveness of the Competence Framework. Course design and assessment methodology will furthermore inform the Competence Framework for its finalization, that will be completed in the 3rd project phase.

The final phase of the project, mainly addressed in the last 6 months of it, will produce the final version of the Competence Framework that will be provided with relevant annexes designed for its adoption at EU level. User guide, methodology and use cases will be provided, according to the activities implemented and the findings gathered during Phase 2. Furthermore, in this phase a strong accent will be put on the framework promotion and adoption. Relevant stakeholders, already engaged since Phase 1, will be contacted for a dedicated workshop presenting and discussing the competence framework. GreenSCENT will furthermore launch its Certification Standard (structured as the ICDL – International Certification of Digital Literacy), with qualifications, proficiency level and assessment; ECCEL – European Certification for Climate and Environmental Literacy – will be designed and implemented as a standard to be adopted at EU level. In the final phase GreenSCENT will also provide guide and policies recommendations developed together with young people and citizens.

4. GreenSCENT pilots

As mentioned above, GreenSCENT core phase is based on a set of Pilot activities that will implement the competence framework, testing and validating it in a combination of different key dimensions:

- Competence areas - GreenSCENT starts from the assumption that the Competence Framework can be based on the focus areas of EU Green Deal Communication, defining 8 key competence areas: climate change, clean energy, circular economy, green buildings, smart and sustainable mobility, sustainable food chain, biodiversity, zero pollution; these 8 areas will be both the main pillars for the 1st release of the framework, and the main topics the Pilots will be built around;
 - Educational levels – GreenSCENT consortium is composed by institutions providing education at different levels, from primary schools to academia. Pilots will therefore allow to test the Competence framework at different EQF levels; furthermore, a special pilot will target citizenship at large, in a non-formal educational context, through the above mentioned open innovation challenges;
 - Engagement levels – citizen engagement and citizen science can range at different engagement levels, from information and awareness to observation, to data collection, to data processing, to impacting on the scientific and policy agenda. GreenSCENT platform will be used as an exploitation and extensive promotion tool in the later stage of the project, as a showcase of existing crowd-sourced contents open to further publications and contribution from students and citizens, available as a knowledge base for both researchers, students, journalists, activist and organizations;
 - Geographical scope – GreenSCENT pilots will take place in 6 different countries: Italy, Spain, Serbia, Finland, Romania, Denmark; but the Open Innovation Challenge will be implemented at EU level, engaging citizens coming from all the member states. Cross-national exchanges will be promoted among pilots, and an automatic translation system will be used to help overcoming language barriers allowing citizens and students from different countries accessing and understanding the crowd-sourced contents on GreenSCENT platform;
 - Blending with transversal competences – GreenSCENT activities will be focused on environment and sustainability related competences; but its implementation will rely and trigger the acquisition of other competences: digital demonstrators will enable digital competences acquisition and improvement, and the hands-on, learning-by-doing approach of the demonstrator will enable the understanding of the scientific methodology and approach. The cross-national dimension of the open innovation challenges and the exchanges promoted at school/university level will promote a European citizenship dimension, contributing to the development of a 3rd millennium EU citizenship.
- GreenSCENT educational piloting will be based on a set of steps:
- Instructional co-design, involving teachers and professors from the partner institutions implementing the pilot locally together with GreenSCENT experts supporting the co-design of the training activity that will be proposed to their students.
 - Preparatory training, in which students will be prepared to the practical activity with the demonstrators that will be the “core” of the pilot activities. The training will be done both in class, for traditional schools and universities, online, in the case of UNINETTUNO (a full online university), or blended, using both in-class activities and digital contents.
 - Experimental activity, engaging students in being active co-constructors of knowledge, using a collaborative and learning-by-doing approach, implemented according to the educational level of the class, and to the focus of the pilot in terms of competence areas and levels. GreenSCENT Demonstrators will be used as the tool enabling students experimenting and “analysing” their knowledge through a “science in the classroom” approach.
 - Final assessment, evaluating both the learning performances of students through teachers’/professors’ evaluation of their activities, and the potential behavioural change generated in students, teachers, citizens through the proposed activities. For the latter, GreenSCENT identified the IAT (Implicit Association Test) as the tool to investigate unconscious perceptions and

attitudes towards sustainable and environmental-aware behaviours. IAT, developed by Harvard university, has already been applied to environmental attitudes (Wilson, Thomas and Smith, 2017).

5. Conclusion: state of the project and next steps

In the first 10 months of the project, beyond the setting up of the project consortium structure and main management tools, the activity was mainly focused on the drafting of the first release of the Competence framework, foreseen for December 2022, and for the design and validation of the research tools that will be used during the piloting.

As a first step in building the competence framework for the 8 areas of the Green Deal, a review was carried out on hundreds of scientific and “grey literature” papers relating to sustainable education. Both scientific publications, and reports from EU, UN, UNEP, UNESCO, OECD, etc. were taken into consideration. The methodologies underlying the literature review can be summarized in three main steps: 1. Review of the literature present in other Competence Framework already developed, validated and published; 2. Search for articles on scientific search engines (Scopus, ERIC) presenting skills related to sustainability with cross-references at all levels of education. 3. Advanced literature search method. From this in-depth bibliographic analysis, a quantitative literature matrix was produced. This matrix is structured by crossing the areas of the Green Deal with the levels of the European Qualification Framework Levels (EQF).

At the same time, another research group worked on defining the research instruments for evaluating the behavioural impacts of the educational activities that will be implemented in pilots. The activity was structured in 3 phases: 1. Identification of the theoretical model for evaluating the change in pro-environmental attitudes and behaviours, through literature review and development of hypothesis on the mutual influence of variables; 2. Implementation of assessment tools, including psychosocial dimensions and the theoretical dimensions chosen considering the 8 Green Deal areas GreenSCENT project is

focusing on; 3. Identification of the skills needed for the implementation of pro-environmental behaviours through a qualitative study identifying specific and transversal skills related to the 8 GreenSCENT focus areas considering the common experiences of citizens interested in eco-sustainability.

A third task performed by the project focused on the establishment of a User Engagement Working Group with the scopes of coordinating the user engagement activities, establishing the User Panel methodology, defining a Design Research methodology and start the research activities conducting individual interviews involving teachers and students through a Co-design Workshop program organized in each of the schools involved in the project and we defined the calendar with the partners.

The next steps of the project will implement the crucial phase of the overall action: once the Competence framework will be finalized, it will become the orientation tool for guiding the instructional co-design of the courses and curriculum that, in partner schools and universities, will support students’ approach to the demonstrators and practical activities; and at the same time, it will be the product to be validated and experimented through citizen engagement activities such as the Youth Design Assemblies and the Open Innovation Challenges that will be coordinate by the project in the set of its demonstrators.

Since the ambition of GreenSCENT is to produce a European Competence Framework adopted from the educational agencies in EU in a lifelong learning perspective, complemented by the ECCEL – European Certification on Climate and Environmental Literacy to be adopted by citizens and companies across Europe as an assessment and certification tool for Green Deal related individual competences, it is therefore necessary to maximize the project capacity to have an impact and be accepted at scientific and policy level. For this reason, UNINETTUNO launched an internal scientific committee, involving high-level scientists already working at international level on climate change, sustainability, ecological transition, with the objective to widen the participation of the committee to a larger number of high level scientists coming from the 10 partner countries of GreenSCENT project partners, and beyond. GreenSCENT Scientific

Committee will manage the scientific responsibility of the main project outputs, fostering the adoption at academic and political level of the conclusion, recommendations and tools developed by the project through the international acknowledgement of the scientists involved. The Scientific Committee will act as a validation body of the project, providing both the scientific guidance for the competence framework long-term evolution and finalization, for the curriculum design at school and academic level, and as already mentioned the final scientific validation of the project outputs.

GreenSCENT aims at involving citizens and especially young citizens across Europe in discussing, co-creating, experimenting and validating a new, operational Competence Framework addressing the 8 main areas of the New EU Green Deal Communication; but above all, GreenSCENT aims at producing outputs and products going beyond the project lifetime, maximizing their adoption through the involvement of all the relevant stakeholders, and creating complementary tools that will help decision makers, institutions, course designers and companies to embrace the behavioural change requested by the Green Deal itself with a full understanding of the scientific motivation and the social implications of it.

References

- Bason C., 2010. *Leading public sector innovation: Co-creating for a better society*. Bristol University Press, Policy Press. DOI: <https://doi.org/10.2307/j.ctt9qgnsd>
- Burrows K., and Patrick L. K., 2016. *Exploring the Climate Change, Migration and Conflict Nexus*. International Journal of Environmental Research and Public Health 13 (4): 1–17. doi:10.3390/ijerph13040443.
- Eurobarometer, 2009. *Europeans' attitudes towards climate change*. European Parliament and European Commission. Retried online on October 2022, URL: https://wwfint.awsassets.panda.org/downloads/european_attitudes_to_climate_change.pdf
- Gregory P.J., Ingram J.S.I., and Brklacich M., 2005. *Climate change and food security*. Phil. Trans. R. Soc. B3602139–2148 <http://doi.org/10.1098/rstb.2005.1745>
- Haines A., Kovats R. S., Campbell-Lendrum D., and Corvalan C., 2006. *Climate Change and Human Health: Impacts, Vulnerability and Public Health*. Public Health 120 (7): 585–96. doi:10.1016/j.puhe.2006.01.002.
- IPCC - Intergovernmental Panel on Climate Change, 2018. *Summary for Policymakers of IPCC Special Report on Global Warming of 1.5°C approved by governments*. IPCC, retrived online on October 2022, URL: https://www.ipcc.ch/site/assets/uploads/2018/02/WG1AR5_SPM_FINAL.pdf
- Krznicaric R., 2015. *The Empathy Effect. How Empathy Drives Common Values, Social Justice and Environmental Action*. At: https://slidelegend.com/the-empathy-effect-friends-of-the-earth_59d1200d1723dd540b135bd9.html
- Santos J.M., and Feygina I., 2017. *Responding to Climate Change Skepticism and the Ideological Divide*. Michigan Journal of Sustainability. Volume 5, Issue 1, 2017. DOI: <http://dx.doi.org/10.3998/mjs.12333712.0005.102>
- Wilson Thomas & Smith T., 2017. *Implicit Environmental Attitudes: Critique and Technique to Promote Awareness*. IAFOR Journal of Psychology & the Behavioral Sciences. DOI: 3. 11-22. 10.22492/ijpbs.3.1.02.

Adaptive management of mitigation projects implemented in rural areas: contribution to Kazakhstan's goal of carbon neutrality

Gulzhamal JAPAROVA, Professor, Rector of Turan - Astana University

Sergey INYUTIN¹, Assoc. prof., Turan - Astana University

Anel AITZHANOVA, Assoc. prof., Turan - Astana University

Lyubov INYUTINA, Independent expert

¹Contact details of corresponding author:

Tel: +7-701- 335-3441

e-mail: s.inyutin@mail.ru

Address: Dukenuly St., 29, 010000, Astana, Republic of Kazakhstan, <https://tau-edu.kz/en/>

Abstract

Achieving ambitious targets for carbon neutrality, strengthening measures to limit CO₂ emissions, the desire of investors to “green” their portfolios in favor of sustainable development will have a significant impact on the fuel and energy complex of many countries. Kazakhstan did not stand aside and set its targets for achieving carbon neutrality by 2060, which in turn ensured the importance of developing green energy in the country. This transition will require careful development planning, significant financial investment, and active community involvement.

In this regard the main vectors and goals of climate change policy, approaches and mechanisms unique for Kazakhstan to involve the population (especially residents of rural areas) in the implementation of mitigation projects aimed to achieve national and international goals in climate change are presented in the article. In particular, the introduction of natural resource management in local landscapes is discussed, as well as innovative mechanisms to support public organizations for collective action to increase social and environmental sustainability, in designing and implementing adaptive management projects.

The innovation, described here is that community-based organizations gained such first experience in Kazakhstan: become to play a leading role in project planning, landscape management, project implementation and monitoring. The introduction of a pilot mechanism - the creating of dialogue platforms where public organizations or collectives interacted with various partners and each other, contributed to replication of green technologies. Effect of this innovation is characterized by broad involvement of population into complex of Climate Change Mitigation, prevention of Land Degradation and Biodiversity Conservation, in quantitative terms, this covered more than 8,000 people; including 55% of women, the total co-financing was increased 11.3%. The number of GHG emission reductions was increased by 48% from the planned indicators in 16 mitigation projects, implemented in 7 landscapes of Kazakhstan thereby increasing local and global benefits: Greenhouse gas emission mitigated 1,529.14 tons of CO_{2e}. All the facilities that have used the RES and EE technologies reduced costs for water heating, electricity, heating etc. for 20-30% as average. The applying the presented approaches and methodologies for the further replication, involving the self-employed population (the percentage of which was 36.3% in 2021) and Youth in such activity is relevant, really contributes to achieving goals in climate policy of Kazakhstan, as analyzed in this article.

Key words: Kazakhstan, Climate Change, Mitigation, adaptive management, carbon neutrality, community-based organizations.

1. Introduction

The 66% of the total area of Kazakhstan (being 272.5 mln. hectares), are prone to desertification, being a semiarid to arid country

with aridity threatens to significantly decrease the resilience of Kazakhstan's ecosystems to land degradation pressures. Kazakhstan pursues consistent policy on the carbon intensity of economy reduction, creation of conditions for

the renewable energy sources (RES) participating in the energy balance of the Republic, undertook the voluntary commitments to reduce greenhouse gases (GHG) emission to the atmosphere and implementation of the national system of greenhouse gases emission quota sale, being developed on the «cap&trade» principle, Kazakhstan takes an active part in the implementation of international projects and programs on the issues related to climate change, as confirmed in the III-VI National Communication of the Republic of Kazakhstan to the UNFCCC. Achieving ambitious targets for carbon neutrality, strengthening measures to limit CO₂ emissions, the desire of investors to “green” their portfolios in favor of sustainable development will have a significant impact on the fuel and energy complex of many countries. Kazakhstan did not stand aside and set its targets for achieving carbon neutrality by 2060, which in turn ensured the importance of developing green energy in the country. This transition will require careful development planning, significant financial investment, and active community involvement.

The rural population in general does not dispose of information, especially those in remote areas namely the impact of environment and climate on the yield and cattle, on the weather forecast is mainly with reference to the regional center, also on opportunities to participate in climate change projects.

In this regards the main vectors and goals of climate change policy, approaches and mechanisms unique for Kazakhstan to involve the population (especially residents of rural areas) in the implementation of mitigation projects aimed to achieve national and international goals in climate change are presented in the article. In particular, the introduction of natural resource management in local landscapes is discussed, as well as innovative mechanisms to support public organizations for collective action to increase social and environmental sustainability, in designing and implementing adaptive management projects.

Turan Astana University staffs and the graduates have experience of cooperation in various international projects, present analysis and expert assessments on the stated topic.

2. The main benchmarks of the climate policy of the Republic of Kazakhstan

Republic of Kazakhstan incorporates climate change issues in the strategic documents, joined the Paris agreement and is committed to achieving the declared contributions to reduce greenhouse gas (GHG) emissions by 15% from 1990 levels by 2030 (Kulibaev T. et al., 2017). To reach this target by 2030, Kazakhstan will need to reduce emissions GHG by 53.4 Mt to 302.8 Mt CO₂e. Provided analysis in this National Energy Report showed that about half of the above target (reducing them by almost 8%) is possible according to already existing or planned for policy implementation. At the same time, the report also provides an alternative scenario, according to which Kazakhstan not only can achieve total emission reductions by 15% under the Paris Agreement, but also go halfway to implementing the conditional target indicator (which is 25%), thanks to a much more significant improving overall energy efficiency, greater reduction in consumption coal and faster capacity expansion wind and solar energy. Prospects of achieving the Intended Nationally Determined Contribution (INDC) of Kazakhstan in the framework of the Paris Climate Agreement was assessed through projections of greenhouse gases (GHG) emissions of 31 large energy enterprises by 2030 (Istomin I, Dronin N., 2019). To meet these commitments technological modernization of the entire industrial sector of the country would be required. Expert assessments confirmed that it could be achieved only by full mobilization of material and financial resources.

Development of RES is in focus of studies in Kazakhstan. The main trends and patterns in the development of the renewable energy sector were studied within the framework of the factor analysis (Nurmukhanova G. et al., 2019), including the factor of uneven energy supply of the regions, which is determined by the shortage of energy resources in certain regions of the country; the factor of exhaustibility of primary energy resources (coal, oil and gas), the influence of global environmental factors. Obstacles for the promotion of RES in Kazakhstan (Inyutin S., Kalashnikov Y., 2013) were studied, the ways of diffusion of Mitigation Technologies in Kazakhstan (Inyutin S., Japarova G., 2017) were

systematized and recommendations to overcome risks to promote small-scale Renewables in Kazakhstan (Aitzhanova A., et al., 2018) were developed. Another study on potential of investments in RES development in Kazakhstan using general scientific methods, as well as quantitative methods of statistical, causal and comparative data analysis was provided in 2022. The results of the study have led to the conclusion that the greatest growth accounts for the share of investment in the development of a “green” economy through increased investment in energy-saving technologies, increasing energy intensity, the development of renewable energy sources, as well as in the protection of atmospheric air (Suyeubaeva S. et al., 2022). It is noted that during the study period, the volume of electricity from wind power plants increased by 6 times, and from solar power plants – 22 times. In general, the work conducted by the experts, shows that there is a significant resource for increasing the effectiveness of achieving the Sustainable Development Goals (SDGs) through a systematic and comprehensive approach within the framework of national policy. It is concluded that a comprehensive roadmap should be developed and adopted at the national level to attract investment in the SDG sectors and ensure that they contribute to the country's sustainable development.

Modern studies of the renewable energy market in Kazakhstan (Lim N., et al, 2021) demonstrate that the introduced mechanisms to stimulate investment in 2011-2013 showed their effectiveness - the capacity of RES stations increased from 94 MW (2011) to more than 1800 MW (2020), which led to an increase in RES to a 3% share in the structure of electricity generation, see Figure 1. Since the beginning of 2011, the number of renewable energy facilities in Kazakhstan has grown from 23 to 111 facilities. Main drivers of growth: legislation, the guarantee of the “green” tariff and the purchase of electricity and the new strategy (according to the “Concept for the transition of the Republic of Kazakhstan to the “Green Economy”): - 3% of the share of renewable energy in the total volume of electricity production by 2020; - 15% share of RES in total electricity generation by 2030; - 50% share of alternative and RES in total electricity generation by 2050.

Kazakhstan embarked on decarbonization of the economy by 2060 (Brekeshev S., 2021) as part of the initiative to introduce “green

technologies” by implementing mitigation projects, introduction of renewable energy sources and energy efficiency. A group of Nazarbayev University scientists has developed a rational scenario for our country to achieve carbon neutrality (Zhumabayev D. et al, 2022), presenting and illustrating a simplified version of the regional “strategy game” in light of the zero-carbon vision for Kazakhstan, as one of the first attempts to understand how to achieve this ambitious goal. About 80% of greenhouse gas emissions come from energy production. Coal is the main source of energy, the transition of the energy sector away from coal will be very difficult. According to the concept of achieving carbon neutrality in the energy sector of Kazakhstan, greenhouse gas emissions during 2017-2050 will decrease from 242.9 million tons of CO_{2-eq} to 30.6 million tons of CO_{2-eq} by 2050, the rest - until 2060. Natural gas is used to maneuver capacities that compensate for the instability of production from renewable energy sources. Approximately in 2035, nuclear power plants are planned to appear in the structure of the electric power industry. Decarbonization in the thermal industry is based mainly on heat pumps at both centralized and individual levels. The decarbonization of the electricity and heat generation sectors as the main consumers of coal leads to the gradual abandonment of coal and its mining. The use of natural gas in the medium term and electricity in the long term will lead to the decarbonization of other sectors. The mathematical model used in the report predicts that in Kazakhstan over the next 25 years the temperature will rise by 2-3 degrees above the 1980-2004 average. Further, in the next 50 years, the temperature will rise by 5-6 degrees Celsius. In the north, the temperature increase will be higher than in southern Kazakhstan. A reduction in summer precipitation is expected in most of the country, which will reduce the volume of agricultural production. The report of scientists presents technologies that can be used and transferred to Kazakhstan to reduce greenhouse gas emissions. These technologies can be applied by people in households (heating, power transmission, energy efficiency optimization of buildings, various energy saving systems), wastewater treatment (anaerobic decomposition process, advanced oxidation process, membrane technology), etc.

All experts recently point out that in order to support the transition to carbon neutrality, it is

necessary to attract various sources of international public and private funding. In connection with the above, the results of 16 mitigation projects implemented by local communities (2018-2021) are currently demonstrated, as described below, using renewable energy and EE technologies, GHG reduction amounted to 1,529.14 tons of CO_{2eq}, reduced costs for water heating, electricity, heating etc. for 20-30% as average (Melikyan L., Inyutina L., 2021).

Due to active cooperation between Partners via dialogue platforms achieved by this piloting the total co-financing was increased 11.3%; the number of GHG emission reductions was increased by 48% from the planned indicators, thereby increasing local and global benefits contributing to achieving carbon neutrality by 2060.

3. A community-based approach to managing natural resources across local landscapes in Kazakhstan

This approach, pioneered in Kazakhstan, is based on a community-driven vision of restoring and maintaining the productivity and resilience of local ecosystems, lessons learned from the COMDEKS program (Melikyan L., Inyutina L., 2021), which has piloted a community-based landscape approach in 20 countries. The goal of Kazakhstan is that Community-based organizations are the driving force in rural development strategies and must take the lead in project planning, landscape governance, project execution and monitoring.

The necessary collective action in Kazakhstan for adaptive management of resources and ecosystem processes for sustainable development and global environmental benefits is hindered by the organizational weaknesses of the communities living and working in affected landscapes to act strategically and collectively in building social and ecological resilience.

For this purpose, the public organizations and NGOs were organized across rural and urban landscapes, supported and trained to apply their knowledge and administrative skills for individual and collective work, in particular, to pilot, innovate and test tools and technologies to increase landscape resilience.

The definition of landscape used in the paper is that of a biophysical as well as cultural and political entity (Buck, L.E, Milder, J., 2006) with

overarching problems of ongoing environmental degradation, economic production, and social cohesion. This allows for a coherent thematic approach to addressing environmental problems in each landscape, determined based on Ecological zones of Kazakhstan. Participatory landscape governance represents an effective foundation for the organization of community-based, multi-stakeholder approaches to land and resource management. Multi-stakeholder groups included community organizations, municipal administrations, private sector representatives, research and educational centers, agricultural and fishing associations and other livelihood interests, youth and vulnerable groups. As result, the 7 regions (or landscapes) of Kazakhstan were determined for projects further implementation and include two broad landscapes: (a) the steppe landscape to include Akmola, Karaganda and Kostanai oblasts; and (b) the desert landscape to include Almaty, East Kazakhstan, Kzylorda, and Turkestan oblasts.

Multi-stakeholder groups conducted consultations and research to define landscape goals, objectives and outcomes for each pilot site in relation to biodiversity conservation (CB) land degradation (LD) prevention, climate change mitigation and adaptation (CC). A total of 49 projects were implemented across 7 landscapes in these three thematic areas including agro ecological practices, adaptive soil and land management, and livestock and fisheries management practices that take into account food security, people's access to resources (techniques for conserving water in conditions of increased salinity and drought), and the ability to adaptation, climate change mitigation and adaptation. The SGP 6 grant projects were selected based on community consultations to ensure that community-led initiatives fit GEF criteria and advance the strategic landscape plans for generating global environmental benefits while sustaining local level development benefits, in including enhanced incomes, food security and disaster risk reduction (Mock, G.2014). Below we focus only on Climate Change mitigation and adaptation projects.

4. Climate change mitigation and adaptation projects, features of successful cases in Kazakhstan

Here we focus only on climate change mitigation and adaptation projects (CC) of covering 16 projects, supporting different

activities of green initiatives (wind or installation of solar generators on farms, in protected areas and as part of community infrastructure; biogas plants, an integrated approach to generating electricity for the needs of the local population (mini-hydroelectric power plants, belt (sleeve) stations, pyrolysis furnaces, wind turbines, carbon sequestration through the restoration of natural forests through the efforts of communities, etc.), including 14 projects on energy efficiency (EE). The 14 EE projects were aimed at creation of pilot demonstration sites based on social facilities and educational facilities in Kostanay, Karaganda, Kyzylorda, East Kazakhstan and Akmola regions; testing innovative financial mechanisms to improve energy efficiency in multi-apartment residential buildings in the Karaganda region; introduction of renewable energy sources and increasing energy efficiency measures through the promotion of green initiatives in the Turkestan efficient technologies in rural areas of Almaty and East Kazakhstan regions.

The expected potential avoided CO₂ emissions over the SGP6's lifetime (2018-2021) was 795.6 tCO₂, while the completed CC grant projects reported the reduction of 1,529.14 tons of CO₂eq (Melikyan L., Inyutina L., 2021), including two EE projects in Karaganda region (upgrading lighting fixtures in 6 secondary schools and implementing an integrated approach to upgrading a 5-storey multi-apartments building (50 apartments) reported a reduction of 732.41 tons of CO₂eq, which is half of the reported amount. Due to active cooperation between Partners via dialogue platforms achieved by this piloting the total co-financing was increased 11.3%; the number of GHG emission reductions was increased by 48% from the planned indicators. Thirteen new EE and RES technologies were tested, including the successful examples of replication as described below.

- Four technologies (EE) greenhouses using polycarbonate, photodiode lighting, drip irrigation and agro-fibre) have been successfully replicated in a social center for persons with mental illnesses in the Michurin village, Pavlodar region (outside the target landscapes) based on experience

and lessons learned of a completed grant project in the Akmola landscape on demonstrating the effectiveness of an integrated approach to the use of energy efficient technologies (including an EE greenhouse) in social facilities for vulnerable people, see below best examples related to *Private Charitable Foundation "Adal Niet Astana", Astana region.*

- Two technologies, i.e., installation of 3 energy efficient furnaces at guest houses and a small-scale solar station for provision of uninterrupted power supply in remote mountain rural areas of East Kazakhstan (outside of target steppe and desert ecosystems, see below best examples related to t NGO Boomerang, Kostanay region.

Best examples of EE projects in Kazakhstan focusing on replication and sustainability: a successful case "Energy efficiency for social adaptation centres in Akmola and Kostanay regions".

- Two NGOs (Private Charitable Foundation "Adal Niet Astana" (Nur-Sultan city), and Public association "Women Ray" (Stepnogorsk city) implemented the so called network project to demonstrate integrated implementation of energy-saving practices based on 2 social rehabilitation facilities with further generalization, dissemination of project approaches based on social centers in other regions of the Republic of Kazakhstan: (1) A rehabilitation center for persons over 18 years of age with mental disabilities, in which 120 people undergo long-term rehabilitation (including 85% - rural residents) and (2) A rehabilitation center for persons who have fallen into a difficult life situation (temporary rehabilitation is provided to 160 people, 80 % of which are women). The facility includes a 40-bed hospice under the auspices of the Ministry of Health of the Republic of Kazakhstan. Strong partnerships with the business, public, the local government bodies (akimats) and Ministry of Labour and Social Protection of the Population of the Republic of Kazakhstan were the cornerstone of the approach in Akmola region

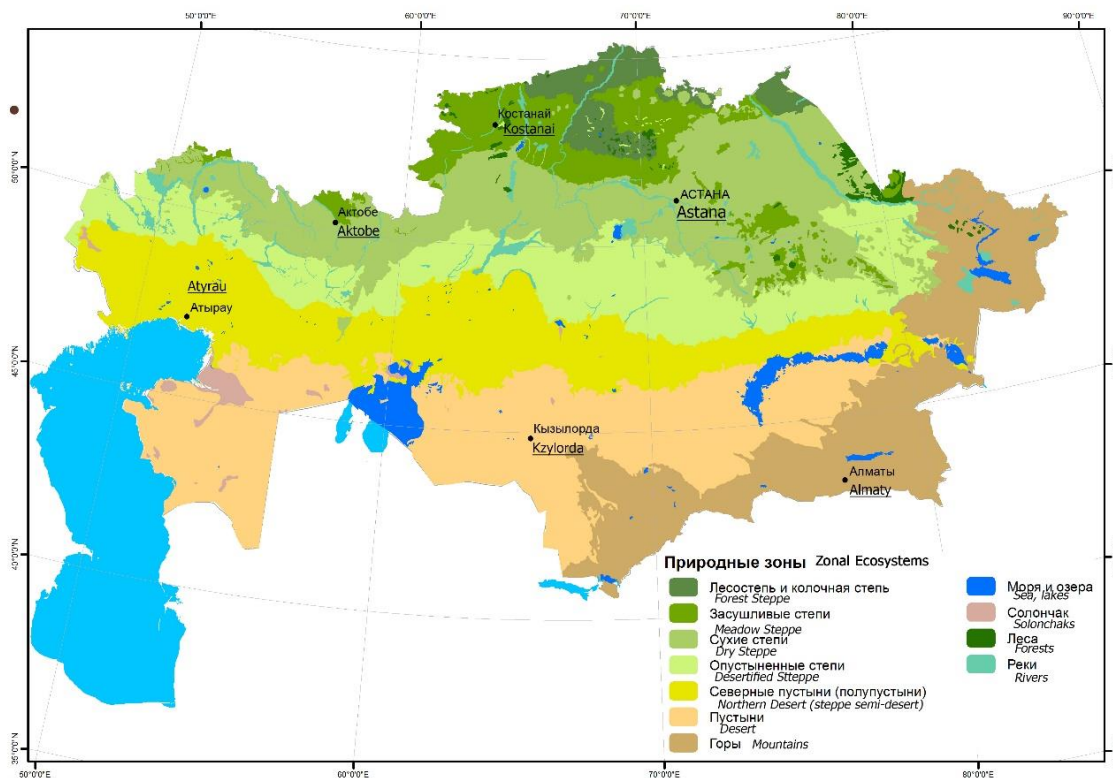

Figure 1: Ecological zones of Kazakhstan, 2017.
 Source: Association for the Conservation of Biodiversity of Kazakhstan (ACBK).

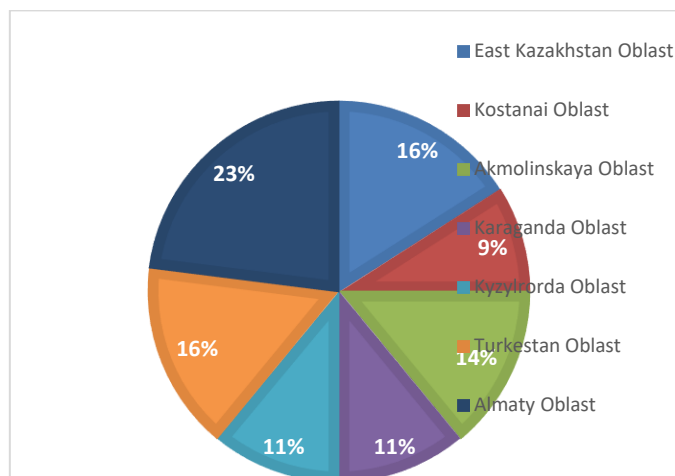

Figure 2: Distribution of the projects by region (Kazakhstan) based on ecological zones. Source: Terminal Evaluation of UNDP/GEF Project: Sixth Operational Phase of the GEF Small Grants Programme in Kazakhstan

- Another NGO Public fund “Crossroad”(in Kostanai city) demonstrated EE technologies within two Social and one Educational Facilities (An Energy-efficient stove was installed and put into operation in the rehabilitation center for people with disabilities “Hachiko”; an automated heating station (ATP) was installed and put into operation in the building of the Public Association “Rudny Voluntary Society of Disabled People” and the building of the Kostanay Agricultural College; EE modernization of indoor and outdoor lighting was carried out in all three

facilities). Good interaction was achieved in Kostanai region with the administration of pilot buildings, the structures of the akimat of Kostanay region, the Department for the coordination of employment and social programs; GU "Education Department of the Akimat of Kostanay region, as well as with the regional maslikhat.

Replication potential is supported by:

○ **Capacity building:**

Akmola region: NGOs conducted exchange visits, with the participation of representatives of ministries and departments, NPP "Atameken" to the round table, media government agencies for the development and support of social centers for long-term rehabilitation in the Republic of Kazakhstan. 2,200 people, as well as at least 220 people of vulnerable groups of the population received training;

Kostanai region: 53 thousand of the population of Kostanay region informed on the progress and benefits of the project, including 8200 people- through the media, 4950 -through social chains, 24,500 people through local TV channel and 15 266 people, through the competition works of the school of Eco bloggers. As a result the project's approach will cover at least 10 social facilities of the Republic of Kazakhstan.

○ **Environmental, social, Gender and economic impacts:**

Akmola region: At least 900 women, 800 - children and youth, as well as at least 220 people of vulnerable groups of the population have improved living conditions through energy-efficient lighting, access to quality food (at least 20 kg of vegetables per 1 m² are obtained, providing 280 people with healthy eating). Besides, 5 energy-saving practices introduced: Energy-saving technologies in 2 greenhouses (use of solar collectors, photodiode lighting) reduce CO₂ emissions by up to 70% and LED lamps in both Centers reduce energy consumption by up to 45%, reduction of CO₂ emissions- by up to 10%. 7 socially vulnerable people got new jobs.

Kostanai region: Reduction of heat energy consumption - 271.2 Gcal; reduction of electricity consumption - 22.4 MWh; decrease

in fossil organic fuel consumption - 70 tons of coal; reduction of CO₂ emissions - 209.4 tons.

○ **Sustainability:**

The experience of the centers of social adaptation has been generalized and disseminated among the administrative structures of the governmental level; similar activity will cover at least 10 social facilities of the Republic of Kazakhstan.

5. Innovative features that characterise the success of projects in Kazakhstan

Government of Kazakhstan in cooperation with Partners via SGP6 supported local initiatives to strengthen local community organizations and NGOs for implementing and replication of projects through:

A. Capacity-building to allow these entities to develop projects, test alternatives, learn how to work with banks, monitor and evaluate results, adjust practices and techniques under the key principles of *learning-by-doing*.

B. Multi-stakeholder dialogue platforms for promotion of the cooperation of participants, adaptive management of the projects, introduce innovative technologies, to apply new practices in the further implementation of similar projects throughout Kazakhstan after SPG6.

The SGP6 supported the establishment of two mechanisms,

- (1) a multi-stakeholder policy platform and
- (2) a multi-stakeholder group to identify landscape-level objectives and monitor results to increase coordination among different groups, so that they may exchange experience while introducing adaptive management, work towards common and broader objectives.

Dialogue platforms were created and operated to improve coordination among different groups so they could communicate, plan, capitalize on each other's comparative advantages and resources, and work towards common and broader goals.

Through the launch of these mechanisms, the goal was achieved: civil society organizations have gained such a first experience in Kazakhstan: they have become the driving force behind rural development strategies and play a leading role in project planning, landscape management, project implementation and

monitoring, including in the field of Climate Change.

Projects cover various focus groups: small and medium-sized farms, private households, schools, colleges, social facilities (centers for people with disabilities, crisis centers for women, centers for disabled children, etc.), the multi-apartment housing sector, dacha cooperatives, fishing associations, rural cooperatives, hunting islands, protected areas, etc.; which has made possible to demonstrate the efficiency of the implemented technologies at various sites for different focus groups. Each project implemented educational and informational work.

C. The innovation was that for the first time in Kazakhstan the socially vulnerable segments of the population were involved in projects related to Climate Change, along with akimats of regions, the social protection departments - divisions of the Ministry of Labor and Protection and the Ministry of Health were involved in monitoring the project results in 2019-2020.

D. Youth participation is reflected in seventeen projects (or 35% of 49), of which 10 - are energy efficiency projects. Youth direct beneficiaries were about 18000 persons in total.

6. Conclusions

1. Kazakhstan set its targets for achieving carbon neutrality by 2060, which in turn ensured the importance of developing green energy in the country. This transition will require careful development planning, significant financial investment, and active community involvement.
2. Successful technologies, practices and systems from community-based initiatives are replicated and promoted for up-scaling by multi-stakeholder partnerships using knowledge and lessons learned from identifying, testing and adapting community innovations for landscape and resource management. The lessons learned showed that through multiple routes for supporting replication and up scaling of successful

technologies, practices and systems of other community-based initiatives, and already there are several cases of replication outside the landscape area.

3. Thanks to active cooperation between Partners through innovative dialogue platforms, the total co-financing of the project increased by 11.3%, the number of GHG emission reductions was increased by 48% from the planned indicators, thereby having an additional effect in the form of local and global benefits. Enhanced cooperation with akimats, central government and development partners (including other international projects) provided a positive impact. All the facilities that have used the RES and EE technologies reduced costs for water heating, electricity, heating etc. for 20-30% as average.
4. The introduction of a pilot mechanism for creating dialogue platforms where civil society organizations, local politicians or collectives interacted with various partners and with various partners and with each other, along with the received relevant training, contributed to improving the effectiveness of adaptive management, replication of green technologies and synergy with regional development programs.
5. The innovation is that civil society organizations have had such a first experience in Kazakhstan: they have become the driving force behind rural development strategies and play a leading role in project planning, landscape management, project implementation and monitoring.
6. Expanding efforts to reach more communities in the regions of all segments of the population, including vulnerable groups and youth, by involving the self-employed population (whose share was 36.3% in 2021) is very important in Kazakhstan. The applying the presented approaches and methodologies for the further replication is relevant, really contributes to achieving goals in climate policy of Kazakhstan, as analyzed in this article.

References

Brekeshv S., 2021. Until 2060, Kazakhstan will move to carbon neutrality. At: <https://primeminister.kz/ru/news/reviews/do-2060-goda-kazahstan-pereydet-na-uglerodnuyu-neytralnost-1103515>

- Istomin I, Dronin N., 2019. Estimates of greenhouse gases emissions reduction potential in Kazakhstan by 2030 in connection with its commitments in the Paris Climate Agreement. RUDN Journal of Ecology and Life Safety. Vol.27, No 1, pp.7-16. At: <https://journals.rudn.ru/ecology/article/view/22105>
- Kulibayev T., KAZENERGY, 2017. National energy report 2017. At: https://www.kazenergy.com/upload/document/energy-report/NationalReport17_ru.pdf; https://unfccc.int/sites/default/files/NDC/2022-06/INDC%20Kz_eng.pdf
- Nurmukhanova G., Zhunussova G., 2019. The assessment of prerequisites for renewable energy development in Kazakhstan. Bulletin of Turan University 2019; No 4, pp. 235-241. (In Russ.). At: <https://vestnik.turan-edu.kz/jour/article/view/889>
- Aitzhanova A., Japarova G., Inyutin S., Inyutina L., 2018. Study on barriers, measures and risks to promote small-scale Renewables in Kazakhstan. At: https://www.worldresearchlibrary.org/up_proc/pdf/1943-154098472301-04.pdf
- Suyeubaeva S., Varavin E., Kozlova M., 2022. Investments in Renewable energy as a level in achieving Sustainable Development Goals of the Republic of Kazakhstan. Journal of the University Turan, No. 2 (94). At: <https://vestnik.turan-edu.kz/jour/article/download/2562/1460>
- Lim N., Zhanadilova Z., Chadiarova J., Begenova S., PwC, 2021. Renewable energy market in Kazakhstan: potential, challenges and prospects. At: <https://www.pwc.com/kz/en/publications/esg/may-2021-rus.pdf>
- Zhumabaev D., Bakdolotov A., Miglio R., Litvak V., Baibakishcheva A., Sarbasov E., Baigarin K., 2022. Kazakhstan's path to zero greenhouse gas emissions. At: <https://nur.nu.edu.kz/bitstream/handle/123456789/6123/Book%20%28ru%29.pdf?sequence=2&isAllowed=y>
- Melikyan L., Inyutina L., 2021. Terminal Evaluation of UNDP/GEF Project: Sixth Operational Phase of the GEF Small Grants Programme in Kazakhstan. At: <https://erc.undp.org/evaluation/evaluations/detail/13062>
- Japarova G., Inyutin S., Aitzhanova A., Inyutina L., 2017. Diffusion of Mitigation Technologies in Kazakhstan. At: https://energy.conference-site.com/archive/2017/proceedings/proceedings_ICERE_2017.pdf
- Inyutin S., Kalashnikov Y., 2013. Obstacles for the promotion of RES in Kazakhstan. At: <http://www.promitheasnet.kepa.uoa.gr/index.php/activities/conferences/9-6th-international-scientific-conference-on-energy-and-climate-change-9-11-october-2013>
- Mock G., 214. Communities in Action for Landscape Resilience and Sustainability. At: <https://comdeksproject.files.wordpress.com/2014/10/communities-in-action-comdeks-web-v2.pdf>
- Buck L.E, Milder J.C., 2006. Understanding Ecoagriculture: A Framework for Measuring Landscape Performance. At: <https://ecoagriculture.org/publication/understanding-ecoagriculture-a-framework-for-measuring-landscape-performance/>

Meleagros, an integrated fire protection system

Dr. Vassileios TSETSOS ¹
CEO, Mobics SA

Dr. Odysseas SEKKAS
Head of Research & Development, Mobics SA

¹ *Contact details of corresponding author*

Tel: +30 2106433525

Fax: +30 2106433407

e-mail: info@mobics.gr

Address: 27 Kifissias Avenue, Athens, 11523, Greece

Abstract

The Meleagros system integrates advanced machine vision algorithms for fire detection. It is a unique two-tier data fusion scheme for better assessment of the field observations and utilizes open protocols and interfaces.

The advanced technology and major innovations incorporated in the Meleagros system meet requirements that other systems fail to meet, offering enhanced functionality, usability and efficiency at lower cost. It includes video smoke and flame detection, Command & Control application for crisis management and a fire simulation engine that executes "parallel" multiple simulations for different scenarios of environmental parameters.

The system is a suitable solution for private or public installations and can be applied in many domains such as forests and natural heritage monuments, plants and industrial facilities, warehouses, malls, monuments, vacation homes etc.

Keywords: fire detection, crisis management, integrated system.



Integrated fire protection system

Dr. Odysseas Sekkas



Meleagros

- An integrated fire protection system
 - Video smoke and flame detection
 - Admin application for crisis management
 - Fire simulation engine
- Suitable for many application domains
 - Forests and natural heritage, Plants and Industrial Facilities, Warehouses, Malls, Monuments, Vacation homes, ...



mobics

Why video fire detection?

- Open or large space fire monitoring is not efficient and cost-effective with other means:
 - Satellite, sensors, ...
- Allows for visual verification of events
- Can work with commodity hardware
- Other events can be simultaneously detected

mobics

Video fire detection

- Basic detection methods
 - Motion detection
 - Color detection
 - Geometry detection

mobics

Video motion detection

- Three basic techniques
 - Background subtraction
 - Difference of two successive frames
 - Optical flow
- Can be common for flames and smokes

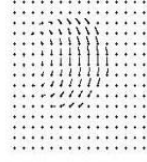

mo
mobics

Video color detection

- Based on color characteristics of flame or smoke
- Both RGB and YUV colorspaces can be used
- Flame and smoke colors may vary

mo
mobics

Advanced detection methods

- Geometry characteristics
 - Smoke: turbulence characteristics
- Space and time variability of fire or smoke pixels
- Motion orientation
 - Smoke moves usually upwards
- Flame flickering

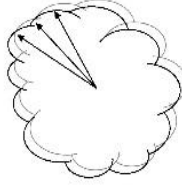

Original frame



mo
mobics

mo
mobics

Motion mask



mobics

Motion mask processed



mobics

Color mask



mobics

Color mask processed



mobics

Combination + other advanced detection algorithms

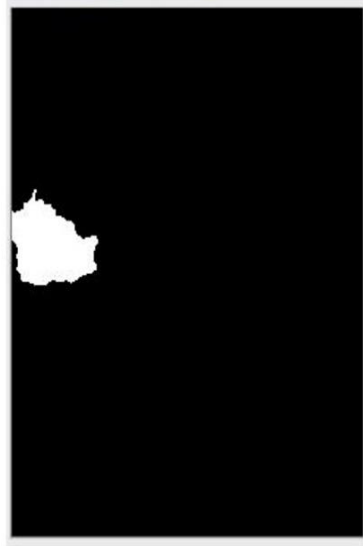



Alarm





Scene characterization

- Characterization of the scene (region of interest, ROI) regarding fuel types
- Speeds up the detection process while considerably reducing the false alarm rate
- Easy to use tool with predefined scene types (e.g. forest, sky, etc.) for image segmentation



Scene Characterization Tool





Characterized Area

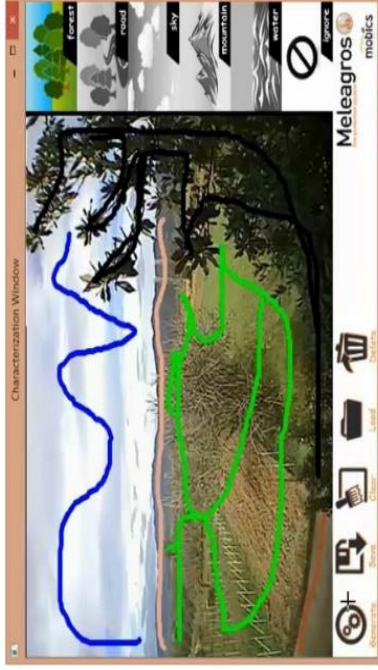

mobics

Algorithm Output

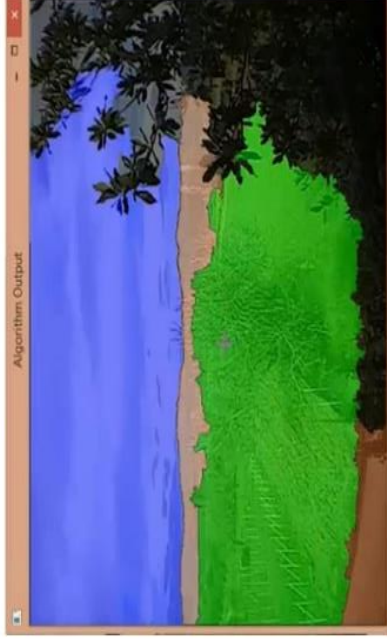

mobics

Produced Mask

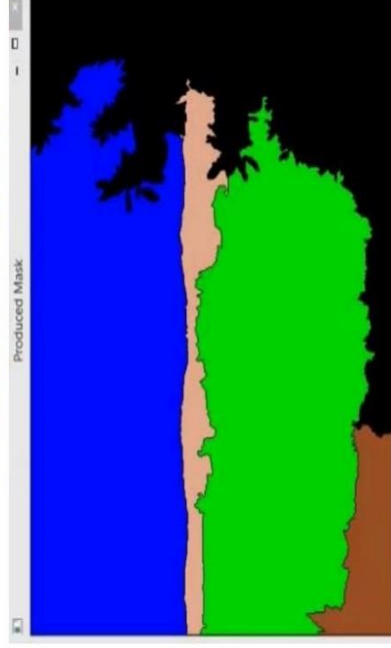

mobics

Control and Management

- Alerts and incidents
- Visual verification
- Equipment tracker
- Historical data
- Simulation engine

mobics

Control and Management

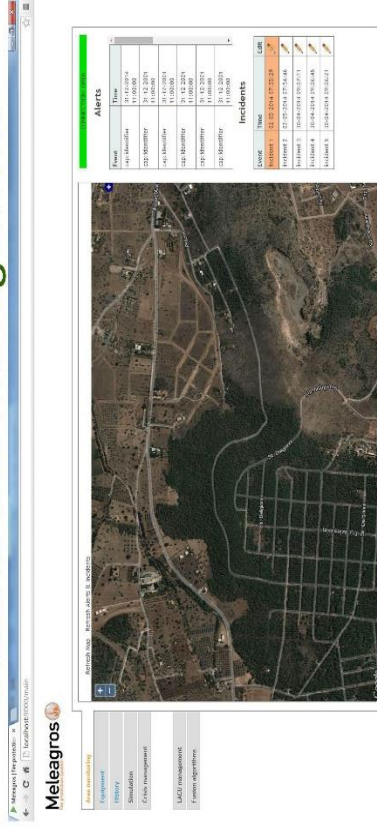

mobics

Fire Simulator

- Fire simulation tools
 - FARSITE
- Maps
 - Google maps, OpenStreetMap
- GIS
 - GRASS, Mapserver

mobics

Fire Simulator



mobics

Thank you!

More information on: www.meleagros.eu

Odysseas Sekkas
sekkas@mobics.gr

mobics

Initiative “75UN – 75 Trees UNAI SDG7”

Dr. Popi KONIDARI¹

Researcher of KEPA

¹ *Contact details of corresponding author*

Tel: +30 72 75 830

e-mail: pkonidar@kepa.uoa.gr

Address: KEPA Building, Panepistimiopolis, Postal code 157 84, Athens, Hellas

Abstract

The Initiative “75UN - 75 Trees UNAI SDG7” was the participation of the Energy Policy and Development Centre (KEPA), as the global hub of the United Nations Academic Impact (UNAI) for the 7th Sustainable Development Goal (SDG7), in the celebrations for the 75th anniversary of the UN foundation. The Initiative aimed at involving citizens in efforts to save and enhance the world's forest wealth. To this aim, KEPA addressed its invitation to governments, regional and local governments, all forms of legal entities, simple people and especially young people to plant at least 75 trees during 2020 and take care of them.

With the support of the Organization for Economic Cooperation of the Black Sea Countries (BSEC) seven Member States responded to this invitation while 29 Municipalities from Greece with the support of the Central Union of Municipalities responded. By the end of 2020, eleven million trees have been declared planted or were about to be planted despite the obvious problems of the pandemic.

Based on the results and especially the willingness of the participants, it was decided to continue and upgrade the Initiative for the coming years. During the planting period 2021-2022, KEPA completed 3.289,00 tree plantings. Once the trees grow, this number will result in annual capture of 74tn CO₂. Purchase and transfer costs for trees and irrigation material were covered by the funding of Hellenic "Green Fund". Eight hundred and fifty (850) olive trees were sponsored by Hellenic Plants. KEPA has started preparations for the forthcoming planting period 2022-2023.

Keywords: Tree planting, climate change, mitigation, adaptation, carbon capture.

15th International Scientific Conference on "Energy and Climate Change"
 12-14 October 2022, Athens-Greece



Initiative
«75UN – 75 Trees UNAI SDG7»

Dr. Popi KONIDARI, Researcher of KEPA

<http://epc2022.com>



Structure

- General information
- Outcomes 2020-2022
- Perspectives



Tree planting at the Municipality of Platania (Crete), 2020





Κέντρο Επιστημονικής Πράξης και Ανάπτυξης
 Εθνικού και Καποδιστριακού Πανεπιστημίου Αθηνών

2



Initiative

- Participation of KEPA, at the celebrations for the 75th anniversary of the UN foundation
- addressed invitation to
 - governments,
 - regional and local governments,
 - all forms of legal entities,
 - simple people and especially young people
- plant at least 75 trees during 2020 and take care of them.
- Aims the participation of citizens in the efforts to save and enhance the world's forest wealth.

Κέντρο Επιστημονικής Πράξης και Ανάπτυξης
 Εθνικού και Καποδιστριακού Πανεπιστημίου Αθηνών

3



Support from

- United Nations Academic Impact (UNAI)
- Organization of Black sea Economic Cooperation (BSEC)
- Central Union of Municipalities of Greece (KEDE)
- Hellenic Green Fund
- Bank of Greece



Municipality of Anapolokipi – Menemmeni 2021



Κέντρο Επιστημονικής Πράξης και Ανάπτυξης
 Εθνικού και Καποδιστριακού Πανεπιστημίου Αθηνών

4



Outcomes 2020-2022



Outcomes 2020

- 9 countries
 - Azerbaijan, Armenia, Bulgaria, Greece, Canada, Moldova, Romania, Ukraine and Turkey
- 29 Hellenic Municipalities
 - 9 registered to the initiative
 - Lokroni, Platanias, Palaio Faliro, Vrillissia, Deskati, Irakleia Seirron, Chalandri, Eretria and Meteora
 - 5 planted trees
- Total of planted or to be planted (commitment)
 - 11 million trees



Municipality of Lokron, 2020



National and Kapodistrian University of Athens
Energy Policy and Development Centre (KEPA)

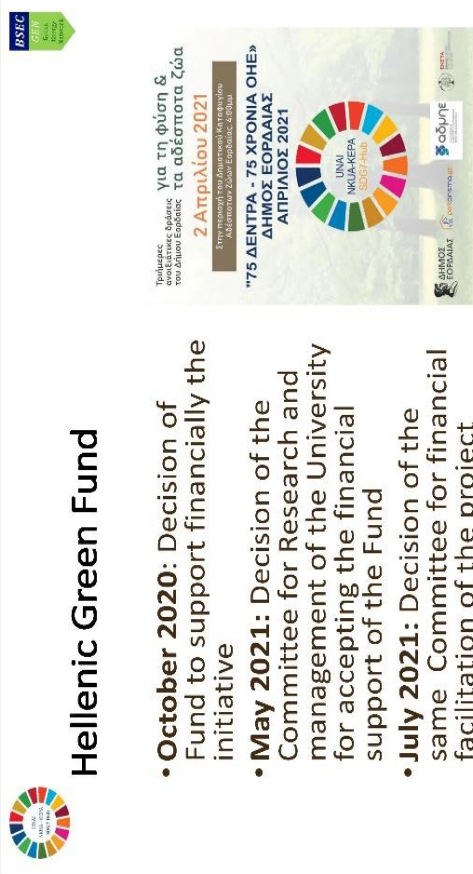

Hellenic Green Fund

- **October 2020:** Decision of Fund to support financially the initiative
- **May 2021:** Decision of the Committee for Research and Management of the University for accepting the financial support of the Fund
- **July 2021:** Decision of the same Committee for financial facilitation of the project



Outcomes 2021 (1)

- From 29 municipalities in 2020 to 61 in 2021
- 28 tele-meetings (average 10-15 persons)
- Contacts with 60 plant nurseries in Greece
 - 10 responded
 - Cooperation with 3
 - 2 in Peloponisos
 - 1 Central Macedonia



National and Kapodistrian University of Athens
Energy Policy and Development Centre (KEPA)

1. Ηλεκτρονική Συνάντηση
2. Ηλεκτρονική Συνάντηση
3. Ηλεκτρονική Συνάντηση
4. Ηλεκτρονική Συνάντηση
5. Ηλεκτρονική Συνάντηση
6. Ηλεκτρονική Συνάντηση
7. Ηλεκτρονική Συνάντηση
8. Ηλεκτρονική Συνάντηση
9. Ηλεκτρονική Συνάντηση
10. Ηλεκτρονική Συνάντηση
11. Ηλεκτρονική Συνάντηση
12. Ηλεκτρονική Συνάντηση
13. Ηλεκτρονική Συνάντηση
14. Ηλεκτρονική Συνάντηση
15. Ηλεκτρονική Συνάντηση
16. Ηλεκτρονική Συνάντηση
17. Ηλεκτρονική Συνάντηση
18. Ηλεκτρονική Συνάντηση
19. Ηλεκτρονική Συνάντηση
20. Ηλεκτρονική Συνάντηση
21. Ηλεκτρονική Συνάντηση
22. Ηλεκτρονική Συνάντηση
23. Ηλεκτρονική Συνάντηση
24. Ηλεκτρονική Συνάντηση
25. Ηλεκτρονική Συνάντηση
26. Ηλεκτρονική Συνάντηση
27. Ηλεκτρονική Συνάντηση
28. Ηλεκτρονική Συνάντηση
29. Ηλεκτρονική Συνάντηση
30. Ηλεκτρονική Συνάντηση
31. Ηλεκτρονική Συνάντηση
32. Ηλεκτρονική Συνάντηση
33. Ηλεκτρονική Συνάντηση
34. Ηλεκτρονική Συνάντηση
35. Ηλεκτρονική Συνάντηση
36. Ηλεκτρονική Συνάντηση
37. Ηλεκτρονική Συνάντηση
38. Ηλεκτρονική Συνάντηση
39. Ηλεκτρονική Συνάντηση
40. Ηλεκτρονική Συνάντηση
41. Ηλεκτρονική Συνάντηση
42. Ηλεκτρονική Συνάντηση
43. Ηλεκτρονική Συνάντηση
44. Ηλεκτρονική Συνάντηση
45. Ηλεκτρονική Συνάντηση
46. Ηλεκτρονική Συνάντηση
47. Ηλεκτρονική Συνάντηση
48. Ηλεκτρονική Συνάντηση
49. Ηλεκτρονική Συνάντηση
50. Ηλεκτρονική Συνάντηση
51. Ηλεκτρονική Συνάντηση
52. Ηλεκτρονική Συνάντηση
53. Ηλεκτρονική Συνάντηση
54. Ηλεκτρονική Συνάντηση
55. Ηλεκτρονική Συνάντηση
56. Ηλεκτρονική Συνάντηση
57. Ηλεκτρονική Συνάντηση
58. Ηλεκτρονική Συνάντηση
59. Ηλεκτρονική Συνάντηση
60. Ηλεκτρονική Συνάντηση
61. Ηλεκτρονική Συνάντηση



National and Kapodistrian University of Athens
Energy Policy and Development Centre (KEPA)

 <h2>Outcomes 2021 (2)</h2> <ul style="list-style-type: none"> • Sponsorship from "Hellenic Plants" <ul style="list-style-type: none"> • 1000 olive trees • 1st International Forestation Initiative • 2 municipalities planted trees  	 <h2>Municipality of Sparta</h2> <ul style="list-style-type: none"> • Park Goude • 104 trees <ul style="list-style-type: none"> • 15 oak trees • 16 walnuts • 15 chestnuts • 10 gossips • 21 plane trees • 11 maple trees • 16 carobs • Pipelines for watering  
 <h2>Municipality of Pilea - Chortiatì</h2> <ul style="list-style-type: none"> • Walking street • 108 trees <ul style="list-style-type: none"> • 18 Aries • 6 Erythritols • 15 Koutsoupies • 30 Cypress trees • 11 Melikoukies • 28 Maple trees • Pipelines for watering  	 <h2>Parallel actions in 2021</h2> <ul style="list-style-type: none"> • Planting at Islet Theodorou • Replanting of memorial olive trees from the location of the new airport  <p>Photo: P. Arvanitis</p> 



Procedure for participation

1. Expressed interest (epgsec@kepa.uoa.gr)
2. Negotiations (exchange of information, clarifications)
3. Memorandum of Understanding
4. Implementation (purchase, planting, enclosure, etc.)
5. Certification
6. Opening



National and Kapodistrian University of Athens
Energy Policy and Development Centre (EPDC)

13



Perspectives

- Contest
- Expand the initiative
- Certificates CO2



National and Kapodistrian University of Athens
Energy Policy and Development Centre (EPDC)

14



Διγλωσσικός Νεολόγος
Bilingual Glossary

«Ο φίλος μου τα δέντρα»
My Friends the trees

Η Πρωτοβουλία
The Initiative

Η πρωτοβουλία «Ο φίλος μου τα δέντρα» ξεκίνησε το 2017 με την πρόθεση να προσφέρει στους πολίτες μια ευκαιρία να συμβάλουν στην προστασία του περιβάλλοντος και να αποκτήσουν ένα δέντρο που θα φυτεύουν στην περιοχή τους. Η πρωτοβουλία είναι ανοιχτή σε όλους και μπορεί να υλοποιηθεί σε οποιαδήποτε περιοχή, πόλη ή χωριό. Η πρωτοβουλία είναι ανοιχτή σε όλους και μπορεί να υλοποιηθεί σε οποιαδήποτε περιοχή, πόλη ή χωριό.

Κατηγορίες
Categories

Η πρωτοβουλία «Ο φίλος μου τα δέντρα» έχει τρεις κατηγορίες: «Πρωτοβουλία», «Κατασκευαστική» και «Πρωτοβουλία». Η πρωτοβουλία «Πρωτοβουλία» αφορά στην προώθηση της πρωτοβουλίας σε νέες περιοχές. Η πρωτοβουλία «Κατασκευαστική» αφορά στην υλοποίηση της πρωτοβουλίας σε συγκεκριμένες περιοχές. Η πρωτοβουλία «Πρωτοβουλία» αφορά στην προώθηση της πρωτοβουλίας σε νέες περιοχές.

Πως λειτουργεί
How it works

Οι πολίτες μπορούν να συμμετάσχουν στην πρωτοβουλία «Ο φίλος μου τα δέντρα» με διάφορους τρόπους. Μπορούν να προτείνουν μια νέα περιοχή, να υλοποιήσουν την πρωτοβουλία σε μια συγκεκριμένη περιοχή, ή να βοηθήσουν στην προώθηση της πρωτοβουλίας σε μια συγκεκριμένη περιοχή.

Επιστροφή με εφαρμογή
Return with application

Η εφαρμογή «Ο φίλος μου τα δέντρα» είναι διαθέσιμη στο Google Play και στο App Store. Μπορείτε να κατεβάσετε την εφαρμογή και να χρησιμοποιήσετε όλες τις λειτουργίες της πρωτοβουλίας.



Thank you

Dr. Popi KONIDARI

Telephone
210 72 75 732
210 72 75 830



Κέντρο Ενεργειακής Πολιτικής και Ανάπτυξης
Energy Policy and Development Centre (EPDC)

15





DAY 3: Brokerage event

Session 2 – Innovation – Start ups

Innovation Fund

Mr. Georgios ZISIS – TEGOS

Head, Section for Market Mechanisms and GHG Emission Registry, Directorate of Climate Change and Air Quality, Ministry of Environment and Energy, Hellas

<p>Ministry of Environment and Energy</p>  <p>Department for Market Mechanisms and GHG Emission Registry</p> <h1 style="text-align: center;">INNOVATION FUND</h1> <h2 style="text-align: center;">15th International Conference on Energy and Climate Change Brokerage and Start-ups outline 14 October 2022</h2>	<p>Ministry of Environment end Energy</p>  <p>Department for Market Mechanisms and GHG Emission Registry</p> <p>The Innovation Fund is one of the world's largest funding programmes for the demonstration of innovative low-carbon technologies.</p>  <p>The Innovation Fund will provide around EUR up to 40 billion of support from 2020 to 2030 for the commercial demonstration of innovative low-carbon technologies, aiming to bring to the market industrial solutions to decarbonise Europe and support its transition to climate neutrality</p>
<p>Ministry of Environment end Energy</p>  <p>Department for Market Mechanisms and GHG Emission Registry</p>  <p>The support is done through calls for large projects (capital expenditure above EUR 7.5 million.) and smallscale projects (capital costs below EUR 7.5 million.) focusing on:</p> <ul style="list-style-type: none"> • innovative low-carbon technologies and processes in energy-intensive industries, including products substituting carbon-intensive ones • carbon capture and utilisation (CCU) • construction and operation of carbon capture and storage (CCS) • innovative renewable energy generation • energy storage 	<p>Ministry of Environment end Energy</p>  <p>Department for Market Mechanisms and GHG Emission Registry</p>  <p>Project proponents can apply via the EU Funding and Tenders portal by submitting their proposals when there is an open call for projects. Projects will be selected based on:</p> <ol style="list-style-type: none"> effectiveness of greenhouse gas emissions avoidance degree of innovation project maturity scalability cost efficiency <p>Additional criteria for geographical and sectorial balance, are set.</p>

Ministry of Environment and Energy



Department for Market Mechanisms and
GHG Emission Registry

Ministry of Environment and Energy

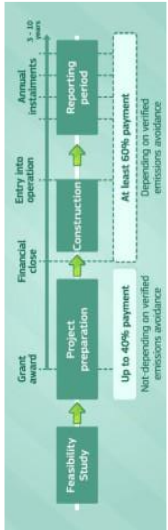

The Innovation Fund will support for :

- large-scale projects, up to 60% of the additional capital and operational costs
- small-scale projects, up to 60% of the capital costs.

The grants will be disbursed in a flexible way based on project financing needs, taking into account the milestones achieved during the project lifetime.

Up to 40% of the grants can be given based on pre-defined milestones before the whole project is fully up and running.

5

Ministry of Environment and Energy



Department for Market Mechanisms and
GHG Emission Registry

Ministry of Environment and Energy

Innovation Fund grants can be combined with funding from other support programmes, for example:

- InnovFin Energy Demo Projects
- Connecting Europe Facility which provides grants for the rollout of key infrastructure
- Horizon 2020 and Horizon Europe
- InvestEU which provides debt and equity financing
- Modernisation Fund
- Just Transition Fund
- Enhanced European Innovation Council (EIC) pilot– grants and equity financing mainly targeted to Small and Medium-sized Enterprises or their consortia
- Private capital

6

Ministry of Environment and Energy



Department for Market Mechanisms and
GHG Emission Registry

Ministry of Environment and Energy

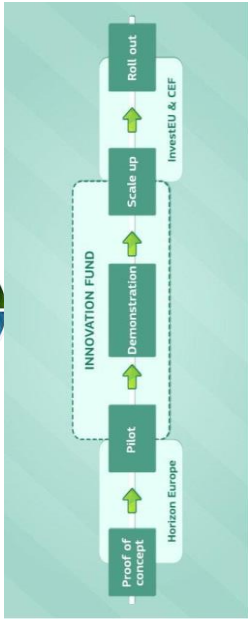

The Innovation Fund grant is not considered to be State aid.

To cover the remaining costs a project applicant can combine the Innovation Fund grant with public support by a Member State.

The amount of public support for a project will depend on the cumulation thresholds of the applicable State aid rules

7

Ministry of Environment and Energy



Department for Market Mechanisms and
GHG Emission Registry

Ministry of Environment and Energy

Overview of the first and second call for largescale project proposals



Large-scale projects
First call : 3.07.2020– 29.10.2020

Budget of EUR 1 billion
311 applications
15 large-scale projects were selected to receive development assistance
7 projects were selected



Small call for large-scale projects
Second call : 26.10.2021– 3.03.2021

Budget of EUR 1.5 billion
139 applications
17 projects were selected for grant

relevant sectors : chemicals, steel, cement, refineries, and power and heat.

Award of the grants and project development assistance – Q4 2022

8

Ministry of Environment and Energy

Department for Market Mechanisms and
GHG Emission Registry

Overview of the first call for smallscale project proposals

Innovation Fund Small-scale projects

Green: Green agreements signed (50 projects)
Blue: Projects awarded project development assistance (10 projects)
Yellow: Projects awarded project development assistance (10 projects)

First call : 1.12.2020- 10.03.2021
Budget of EUR 100 million
232 applications
32 successful applicants were invited to start the grant preparation process
project development assistance was awarded to 10 rejected proposals

9

Ministry of Environment and Energy

Department for Market Mechanisms and
GHG Emission Registry

Third call for largescale projects

The REPowerEU Plan has announced how the Innovation Fund will be strengthened to further support the EU's independence from Russian fossil fuels.

Apart from the general call for proposals, REPowerEU will support :

- innovative electrification and hydrogen applications in industry,
- innovative clean tech manufacturing (such as electrolyzers and fuel cells, innovative renewable equipment, energy storage or heat pumps for industrial uses), and
- mid-sized pilot projects for validating, testing and optimising highly innovative solutions.

The Commission will double the funding available for the next large-scale call of the Innovation Fund to around EUR 3 billion.

Launch of the third large-scale call : November 2022
Deadline for submission of applications : Q1 2023

10

Ministry of Environment and Energy

Department for Market Mechanisms and
GHG Emission Registry

Second call for small- scale projects

The funding available for the smallscale projects call of the Innovation Fund is EUR 100 million

Launch of the second small-scale call : 31 March 2022
Deadline for the submission of applications : 31 August 2022
Information on evaluation results and invitation for grant preparation : Q1 2023
Award of the grants and project development assistance : Q2 2023

11





Ministry of Environment and Energy

Department for Market Mechanisms and
GHG Emission Registry

Georgios Zisis Tegos
National Contact Point
Head of Department for Market Mechanisms and GHG Emission Registry
tel. : +30.210.86.26.000
email : g.zisis@priv.ypeka.gr

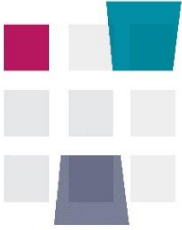
Innovation and Networking

Ms. Varvara VASILAKI
National Documentation Centre, Hellas

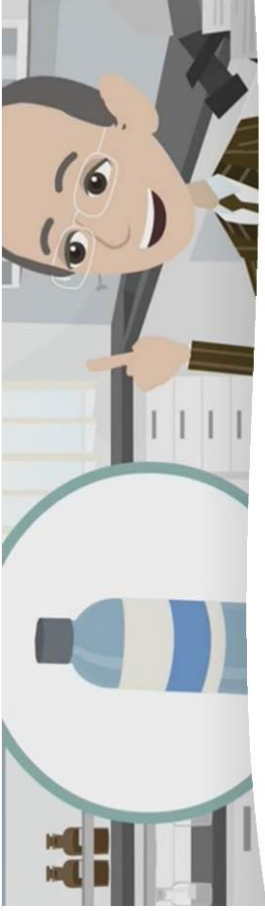
 <p>INNOVATION AND NETWORKING UNIT Integrated services for Fostering Innovation Networking and Technology Transfer</p> <p>Varvara Vasilaki Innovation Consultant National Contact Point #HorizonEU & #EIT-Health Project Manager National Documentation Centre, EKT</p> <p>Athens, 14 October 2022</p> 	<p>WHO WE ARE</p> <p>The National Documentation Centre (EKT) is a Greek research centre and a public organisation supervised by the Ministry of Digital Governance.</p> <p>Strategically connected with the stakeholders of the Greek innovation ecosystem, EKT supports:</p> <ul style="list-style-type: none">• evidence-based public policy making with valid data provision• open data and open science• interaction between research and business• digital transformation and innovation  
<p>INNOVATION</p>  <p>'There is a way to do it better. Find it!'</p> <p><i>Thomas Edison</i></p>	 <p>INNOVATION – From Lab to Market</p> <p>https://www.youtube.com/watch?v=A5n5ffPZEoM</p>

Services and Networks

Horizon Europe

Enterprise Europe Network

Knowledge Bridges

EIT Health

Metrics Publications

Communication Dissemination

InnovationEKT

Enterprise Europe Network

The largest internationalisation and innovation support network in the world!

3.000+ Advisors

600+ Organisations

65 Countries

Logos: EKT NATIONAL DOCUMENTATION CENTRE, Enterprise Europe Network, National Documentation Centre

#EENCanHelp EKT : Coordinator of the Greek hub «Enterprise Europe Network – Hellas»

16 established institutions that support entrepreneurship and innovation

InnovationEKT

#EENCanHelp Who comes to us?

Startups

Scaleups

Spinoffs

SMES

Public organisations

Universities & Research Technology Organisations

Cooperatives and social enterprises

Corporates

InnovationEKT

15th International Conference on Energy and Climate Change, 12-14 October 2022 (in situ and on line)

#EENCanHelp

NETWORKING SERVICES

Promote and facilitate partnerships

Support participation in communities and knowledge networks

ADVISORY SUPPORT SERVICES

Access to funding

Access to market and technology transfer

Innovation management

INFORMATION & COACHING SERVICES

Raising awareness

Capacity building



InnovationEKT

NETWORKING SERVICES

Matchmaking/Brokerage
Events & Company Missions



InnovationEKT

<div data-bbox="295 1780 438 1948" data-label="Image"> </div> <div data-bbox="335 1512 422 1736" data-label="Text"> <p>Become more Resilient, Digital and Sustainable</p> </div> <div data-bbox="335 1176 470 1377" data-label="Image"> </div> <div data-bbox="486 1736 758 1948" data-label="Image"> </div> <div data-bbox="494 1377 758 1724" data-label="Image"> </div> <div data-bbox="598 1960 726 1993" data-label="Text"> <p>InnovatoneKT</p> </div>	<div data-bbox="295 862 438 1030" data-label="Image"> </div> <div data-bbox="335 571 422 817" data-label="Text"> <p>Resilience, Digitalisation, Sustainability</p> </div> <div data-bbox="438 347 542 817" data-label="Text"> <p>Update on sustainability/digitalization/gender & women's entrepreneurship issues. Information about access new markets. Information on financing tools, sustainable financing tools etc.</p> </div> <div data-bbox="582 761 726 996" data-label="Image"> </div> <div data-bbox="582 492 726 705" data-label="Image"> </div> <div data-bbox="726 459 758 705" data-label="Text"> <p>The Challenge of "Legal Support in a "Scale Up" Business: Investors, "New Markets, Contracts"</p> </div> <div data-bbox="598 1030 726 1064" data-label="Text"> <p>InnovatoneKT</p> </div>
<div data-bbox="861 1624 893 1982" data-label="Section-Header"> <p>Services for circularity and sustainability</p> </div> <div data-bbox="917 1579 1021 1982" data-label="Image"> </div> <div data-bbox="1037 1556 1173 1859" data-label="Image"> </div> <div data-bbox="901 1187 1045 1534" data-label="Text"> <p>Sustainability Assessment Services ✓ by certified innovation consultants - EEN members ✓ Highlights strengths/weaknesses of the business ✓ action plan for sustainability / more resource efficiency</p> </div> <div data-bbox="1053 1187 1117 1534" data-label="Text"> <p>Methodology & Tools Kearney/ IMPProve Corporate Sustainability Navigator</p> </div> <div data-bbox="1149 1187 1292 1523" data-label="Image"> </div> <div data-bbox="1173 1960 1300 1993" data-label="Text"> <p>InnovatoneKT</p> </div>	<div data-bbox="845 526 877 1075" data-label="Section-Header"> <p>Sustainability & Digital Technologies / Digital Transformation</p> </div> <div data-bbox="909 582 1308 940" data-label="Diagram"> </div> <div data-bbox="1173 1030 1300 1064" data-label="Text"> <p>InnovatoneKT</p> </div> <div data-bbox="965 257 1197 504" data-label="Text"> <p>Digital technologies can help a business: • Become more circular and more sustainable. • Collect and analyze data. • To monitor procedures, etc.</p> </div> <div data-bbox="1316 537 1372 1064" data-label="Text"> <p>Digital technologies facilitating the scale-up of circular business models. "Digitalisation for the transition to a resource efficient and circular economy". DECD Environment Working Papers, No. 192. https://doi.org/10.1787/6f6d18c7-en.</p> </div>

What are the results and impact?

- 159 companies have signed business, technology or research partnerships
- 3,313 companies attended international brokerage events and company missions
- 6,462 people participated in events
- 3,026 targeted business meetings
- 8,750 questions on EU issues answered

2020 - 2021

#HorizonEU (2021-2027): The most ambitious EU Framework Programme on Research & Innovation with a budget of €95.5 billion with a particular focus on creating impact / the European Green Deal, the digital and sustainability transition and recovery from the coronavirus-crisis.

HORIZON EUROPE

SPECIFIC PROGRAMME IMPLEMENTING HORIZON EUROPE & EIT
Exclusive focus on civil applications

Pillar I: EXCELLENT SCIENCE
European Research Council
Marie Skłodowska Curie
Research Infrastructures

Pillar II: GLOBAL CHALLENGES & INDUSTRIAL COMPETITIVENESS
European Innovation Council
European Innovation Ecosystems
European Institute of Innovation & Technology

Pillar III: INNOVATIVE EUROPE
European Innovation Council
European Innovation Ecosystems
European Institute of Innovation & Technology

EURATOM

Fusion
Fission
Joint Research Center

** The European Institute of Innovation & Technology (EIT) is not part of the Specific Programme*

Adaptation to climate change, including societal transformation

Mission areas

- Healthy oceans, coastal and waters
- Cancer
- Climate-resilient and smart cities
- Soil health and food

[Find Open Calls here](#)

[Find your National Contact Point here](#)

European Institute of Innovation & Technology (EIT)
– Knowledge Innovations
EIT KICs & HUBS

- EIT : the Greek EIT Health hub
- We create an environment where the brightest minds can explore new ideas and find practical resources to create products and services rooted in innovation
- Up till now more than 90 Greek startups have participated in specialised programmes, while 19 of them received awards and funding

SUCCESS STORIES

A Greek company meets Airbus



ICT Progress Day 2017
 16th September 2017 - 16th November 2017
 4th Energy & Environment in Greece, Athens & 20th September 2017
 17th Energy & Environment in Greece, Athens & 20th September 2017
 International Journal of Energy & Environment Research, Vol. 10, No. 1, 2017
 International Journal of Energy & Environment Research, Vol. 10, No. 1, 2017
 International Journal of Energy & Environment Research, Vol. 10, No. 1, 2017



SUCCESS STORIES



...and participates in a consortium of 28 organizations receiving funding & conducting research on 5G technology





More information here: <https://www.ekt.gr/el/news/24616>





SUCCESSFUL CONSORTIA AT EU FUNDED PROJECTS & PARTNERS

Spyros Fountas
Associate Professor,
Agricultural University of Athens



Nektarios Kozyris
Professor,
National Technical University of Athens





Charilaos Koumaras
Assistant Professor,
NCSR Democritus



"I have not failed 10,000 times—I've successfully found 10,000 ways that will not work."

Thomas Edison



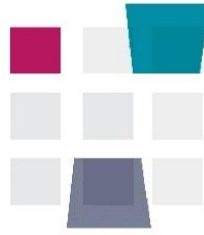

Thank you for your attention !

Varvara Vasiliaki, MSc. | vasiliak@ekt.gr | www.ekt.gr
Innovation Consultant, Innovation & Networking Unit



Startup Greece

Mr. George PROKOPOS



f t in @
www.startup-greece.org

1

Our vision is to inspire and support people in order to show them that everyone can create value from nothing and create a positive social or economic impact in the world.

2

Mission SDG Alignment

UN's Sustainable Development Goals

Being compliant with the UN's Sustainable Development Goals is vital for our **mission**. As an NGO, we aim at creating **strong** and **diverse inclusive** communities by **democratizing** the sources of knowledge and by making all the necessary means available to every social group for the **sustainable development** of the Startup ecosystem. Our actions are planned with the following SDGs in mind.



SUSTAINABLE DEVELOPMENT GOALS

4
QUALITY
EDUCATION



5
GENDER
EQUALITY



8
DECENT WORK AND
ECONOMIC GROWTH



9
INDUSTRY, INNOVATION
AND INFRASTRUCTURE



10
REDUCED
INEQUALITIES



11
SUSTAINABLE CITIES
AND COMMUNITIES



What we do
at Startup Greece...

4

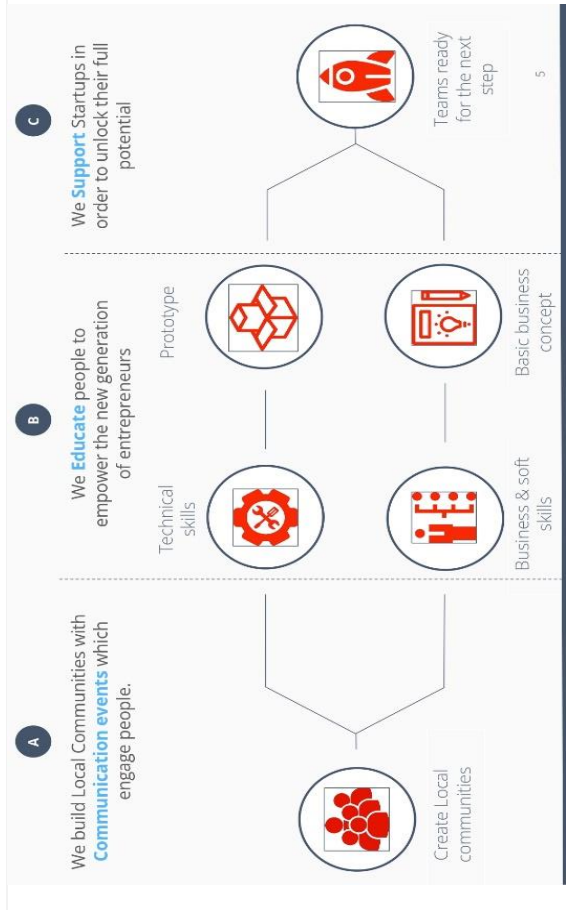

5

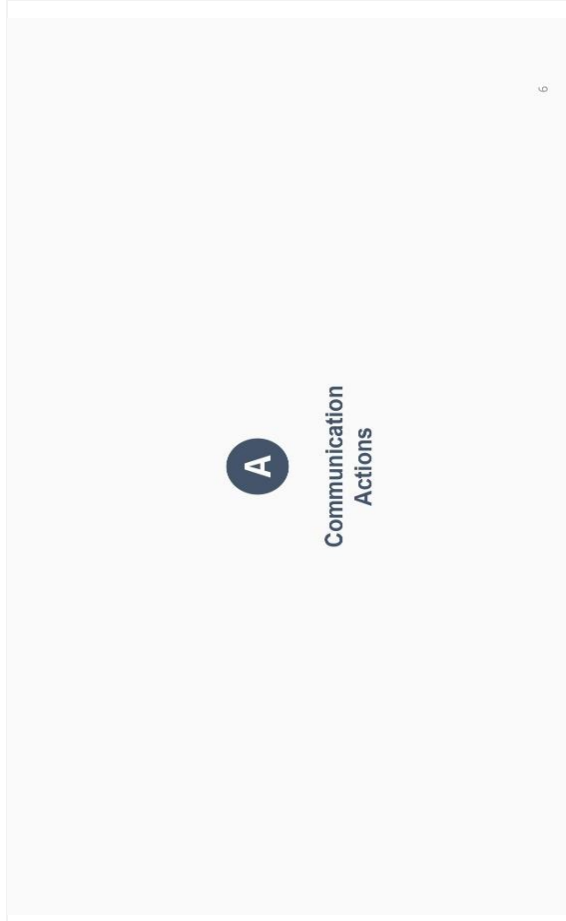

6

Series of events in Greek cities

Startup Greece Week main objective is to listen, discuss and communicate the experience and point of view of individuals who are in the entrepreneurial ecosystem. Accordingly, through their knowledge and inspiration, we want to mobilise the creation of new business entities that will allow new dynamics in the Greek society and economy

2016 - 2021
200+ 320+ 200+ 5500+
 Startups Speakers Volunteers Attendees

When:
November 2021, 6th Edition

7

Startup Greece Week 2020
 in numbers

The largest 100% online conference worldwide for startup entrepreneurship, in 2020.

7 Days	60 Volunteers	126 Speakers
52 Hours Live	2170 Live Attendees	41 Countries
76 Supporters	1+ million reach	500k views

8

Startup Greece in Universities

These events aim to present the opportunities given to students during their academic years in order to develop their **entrepreneurial skills**, enrich their CVs and find what they really like to do in their lives.

They are, therefore, a source of inspiration for the beginning of a **creative generation**.

When:
Every Autumn

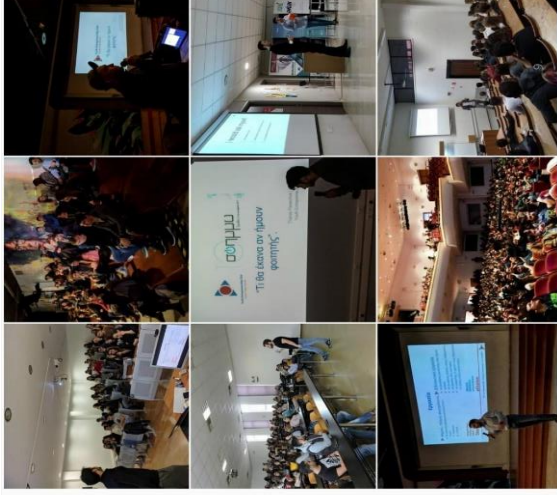

Startup Greece Talks in Cities Inspirational Talks about Innovation & Entrepreneurship

YEC Talks is a set of **open discussions** among successful entrepreneurs, businessmen and the audience.

When we say open discussions, we want to put a particular emphasis on the word "open". We firmly believe that **innovative ideas** thrive in open and collaborative environments, where everybody is allowed to express his/her opinion and satisfy his/her curiosity rather than just passively listening.

Our primary goal is to motivate people and show them the necessary steps to turn their idea into reality. In order to do so, we aim at creating every time a **networking experience** and provide our attendees an idea of how business environment works.

When:
Once a month



B

Educational Programs



YEC School of Innovation & Entrepreneurship Local & Online Educational Program



The **School of Innovation & Entrepreneurship** is consisted of 8 different units and it is held from October to May in **Chania**. The overall duration of the program is **120 hours**. At the end of the school, the **100 graduates** will be ready to fulfil their true potential in order to build a **startup** and make sure it will succeed.

The **online version** Brainifactory 'From Idea to Launch' is a 10-week program that helps university students & recent graduates to learn the skills that are required to start their businesses. It gives the opportunity to all participants to be connected with successful Greek startup **founders** and business **consultants**, all over the world.

When:
Once a year

<p>SG Business Trips Day visits in local businesses</p>  <p>Business Trips give the opportunity to young people to gain first-hand knowledge about different business environments and production lines. We strongly believe that this knowledge will be used as a lighthouse for the most suitable career.</p> <p>When: Twice a year</p> <p style="text-align: right;">13</p>	<p>SG Erasmus+ Projects Strategic Partnerships & Exchange programs</p> <p>In the last 2 years, we have taken part in 9 Erasmus+ KA1 & KA2 projects and cooperated with partners from more than 15 countries. All these projects have given excellent communication and adaptability skills to all our organization's members.</p> <p>Our main focus now is on Green Erasmus+ and Digital Erasmus+ projects. We are ready to have a leading role, working towards a greener, more digital & more inclusive Europe!</p> <p>When: Running</p> 
<p style="text-align: center;">C</p> <p style="text-align: center;">Startup / Spinoff Support</p> <p style="text-align: right;">15</p>	<p style="text-align: center;">Our organization is accredited as an incubator by the Ministry of Development and Investments of the Hellenic Republic.</p> <p style="text-align: center;">  HELLENIC REPUBLIC MINISTRY OF DEVELOPMENT AND INVESTMENTS </p> <p style="text-align: right;">16</p>

European Startup Universe



The 6-week online program for European early-stage tech startup founders

The ESU consisted of 8 National Programs, where 1500 participants, startups founders, had the chance to take part in a series of non-formal education activities that eventually will lead them in securing funding for their startups. The ESU inaugurated its activities from December 2021 and reached its peak with the completion of the online educational programs that took place in March and April 2022. The educational programs were hosted through the Founderhood platform.

Despite the program being addressed to EU Startups Founders, the organizers, in the spirit of solidarity, included the startup founders from Ukraine, with the purpose of reinforcing the startup ecosystem of Ukraine.

Throughout the project, the participants had the chance to participate in a series of activities such as:

- Office hours: weekly Q&A talks with well established European Founders and investors that operate on a national level.
- Workshops: Interactive workshops that were centered around issues that startups encounter in their early stages. Some of the topics were Team Building, Product Development, Business Development, Fundraising etc.
- Community forums which enabled communication between them
- 1 on 1 Meetings, where founders had the opportunity to meet online and discuss with European Experts, who work or collaborate with well established organizations (Facebook, Google, IBM, Salesforce, Netflix, MIT, Harvard etc.)
- Educational Content.
- Perks, where exclusive offers or free software was available

17

Startup Universe in numbers

EU Founders	1500+	900+	Startups	60	Speakers	123	Experts
Founders located in	32	countries	Business opportunities in	20+	markets	37	Angel investors
Partners	43	Perk Providers	Startups matched with investors	16	90		

What we have achieved?

19

20

Startup Network

R growthmentor iqrate shades for you inclusive dining if P H E E TERRA INSECTA Agroknow OWIVI learnWorlds Eliademy TOORISTAS

25

EV Loader - Recyclist - Cyclefi Coffeeco - Solmeya

Being compliant with the UN's Sustainable Development Goals is vital for our **mission**. As NGOs, we aim at creating **strong** and **diverse inclusive** communities by **democratizing** the sources of knowledge and by making all the necessary means available to every social group for the **sustainable development** of the Startup ecosystem. Our actions are planned with the following SDG's in mind.

26

Ependysis Business Consultants

Mr. Ypsilantis TZOUROS

15TH INTERNATIONAL CONFERENCE ON ENERGY AND CLIMATE CHANGE

ENTREPRENEURSHIP, FINANCIAL TOOLS FOR THE ENVIRONMENT AND CLIMATE CHANGE

YPSILANTIS TZOUROS, CEO EPENDYSIS BUSINESS CONSULTANTS

ABOUT US

Ependysis is a business consulting company with the aim of providing specialized services to companies in the private sector, but also to organizations in the wider public sector.

Our methodology focuses on the strengthening of our client, on its domestic and international development and on its constantly increasing market share.

3D BUSINESS MODEL

- 01 Financial Tools
- 02 Business Consulting
- 03 Extroversion

OUR SERVICES

We achieve that with our 3D Business Model:

Financial Tools

- Grants
- EU Funding

Business Consulting

- Feasibility Study / Business Plan
- Strategic Positioning
- Day to day Management

Business Extroversion

- Marketing Plan
- Day to day Marketing
- Branding

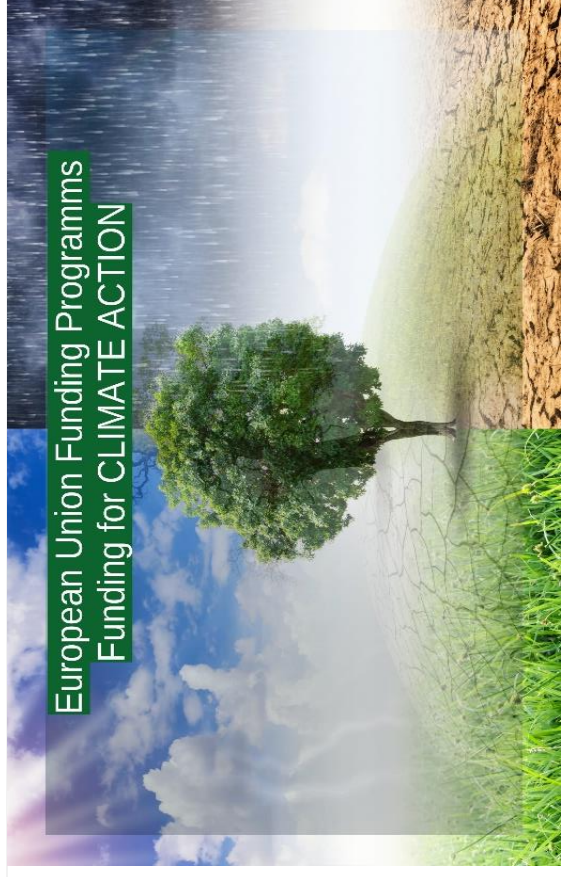

European Union Funding Programms Funding for CLIMATE ACTION

European Union Funding Programms
Funding for climate action

EU budget 2021-2027: Commission proposal to further strengthen climate action

The EU's 2021-2027 long-term budget, together with the NextGenerationEU recovery instrument, amounts to €2.018 trillion in current prices (€1.8 trillion in 2018 prices).

This unprecedented response will help repair the economic and social damage caused by the coronavirus pandemic and aid the transition towards a modern and more sustainable Europe.

30% of the EU budget will be spent to fight climate change.





European Union Funding Programms
Funding for climate action

Innovation Fund

The Innovation Fund is one of the world's largest funding programmes for the demonstration of innovative low-carbon technologies.

In the EU, polluters have to pay for their greenhouse gas emissions via the Emissions Trading System (ETS). The money raised via the ETS is reinvested into the Innovation Fund: one of the world's largest funding programmes for innovative low-carbon technologies.

The Innovation Fund calls for proposals are prepared with the active involvement of the Innovation Fund Expert Group.



European Union Funding Programms
Funding for climate action

Modernisation Fund

The Modernisation Fund is a dedicated funding programme to support 10 lower-income EU Member States in their transition to climate neutrality by helping to modernise their energy systems and improve energy efficiency.

The beneficiary Member States are Bulgaria, Croatia, Czechia, Estonia, Hungary, Latvia, Lithuania, Poland, Romania and Slovakia.

The total revenues of the Modernisation Fund may amount to EUR 48 billion from 2021 to 2030 (at EUR 75/tCO₂), depending on the carbon price. Out of this amount, around EUR 28 billion comes from allowances that beneficiary Member States have transferred to the Modernisation Fund from their resources under Article 102(b) and 10c, and around EUR 20 billion comes from the auctioning of 2% of the total EU ETS allowances from 2021 to 2030.



European Union Funding Programms
Funding for climate action

LIFE Climate Change Mitigation and Adaptation

The LIFE programme 2021-2027 is divided into four sub-programmes: "Nature and biodiversity", "Circular economy and quality of life", "Climate change mitigation and adaptation" and "Clean energy transition".

LIFE contributes to the transformation of the Union into a climate-neutral and resilient society, by supporting the implementation of the EU's climate policy as part of the Green Deal for Europe and preparing the EU for the climate challenges in the coming years and decades.



European Union Funding Programms
Funding for climate action

LIFE financial instruments

Private Finance for Energy Efficiency (PF4EE)

Private Finance for Energy Efficiency (PF4EE) instrument is a joint agreement between the European Investment Bank and the European Commission which aims to address the limited access to adequate and affordable commercial financing for energy efficiency investments.

The instrument targets projects which support the implementation of National Energy Efficiency Action Plans or other energy efficiency programmes of EU Member States.



European Union Funding Programms
Funding for climate action

LIFE financial instruments

Natural Capital Financing Facility (NCFF)

Halting the loss of biodiversity and adapting to climate change requires increasing investment in natural capital.

To do so, the European Investment Bank and the European Commission have partnered to create the Natural Capital Financing Facility (NCFF), a financial instrument that supports projects delivering on biodiversity and climate adaptation through tailored loans and investments, backed by an EU guarantee. At the same time, projects financed through the NCFF need to generate revenues or demonstrate cost savings.



European Union Funding Programms
Funding for climate action

NER 300 programme

NER 300 is a funding programme pooling together about EUR 2 billion for innovative low-carbon technology, focusing on the demonstration of environmentally safe Carbon Capture and Storage (CCS) and innovative renewable energy technologies on a commercial scale within the EU.

Further NER 300 calls for proposals are not planned. The Commission now focuses on the projects already selected for funding and on preparing the first call under the new Innovation Fund.





European Union Funding Programms Funding for ENERGY ACTION

European Union Funding Programms Funding for energy action

Cohesion Fund

The EU's Cohesion Fund aims to reduce economic and social disparity between EU countries and promote sustainable development.

The fund supports energy-related projects that benefit the environment for example by reducing greenhouse gas emissions increasing the use of renewable energy or improving energy efficiency.

Part of the Cohesion Fund is used to implement the energy union strategy with the help of the Energy and Managing Authorities Network (EMA).



European Union
Cohesion Fund

European Union Funding Programms Funding for energy action

Connecting Europe Facility

The Connecting Europe Facility (CEF) is the EU's funding instrument for boosting energy, transport, and digital infrastructure.

In 2018, the CEF was renewed for 2021-2027 with a budget of €42.3 billion to support investments in EU infrastructure networks for energy (€8.7 billion), transport (€30.6 billion) and digital (€3 billion). This represents a 47% increase compared to 2014-2020, see "EU Budget for the future" CEF factsheet for further information.

Every 2 years the European Commission draws up a list of EU projects of common interest (PCIs) which may apply for CEF funding. The first CEF Energy PCI call for proposal was launched on 7 September 2021, making €785 million available to finance clean energy infrastructure projects.



European Union Funding Programms Funding for energy action

European Investment Bank and the European Fund for Strategic Investments

The European Investment Bank (EIB) helps finance energy projects by providing companies with loans and other financial instruments. The EIB, together with the European Commission, launched the European Investment Advisory Hub as part of the Investment Plan for Europe. The hub acts as a single access point that provides advice and expertise on administration and project development across the EU.

In November 2019, the EIB adopted a new and more ambitious energy lending policy that aims to phase out traditional fossil fuel energy projects by 2021.

The European Fund for Strategic Investments (EFSI) is a joint initiative between the EIB Group (the EIB and the European Investment Fund) and the Commission. It aims to mobilise private investment in projects which are strategically important for the EU, including the areas of energy efficiency, renewable energy, power grids and interconnectors – all essential to speed up the decarbonisation of the EU economy.



European Union Funding Programms
Funding for energy action

European Regional Development Fund

The European Regional Development Fund (ERDF) aims to reduce economic and social disparity between the EU's regions. One of the ERDF's four priority areas for 2014-2020 is 'the low carbon economy'.

A minimum percentage of ERDF funding must be channelled towards low carbon projects in regions: 20% for more developed regions, 15% for transition regions and 12% for less developed regions.



European Union Funding Programms
Funding for energy action

Horizon 2020 and Horizon Europe

Around €5.8 billion will be invested in energy research and innovation projects in the EU's Horizon Europe programme 2021-2022. These projects aim at the creation and improvement of clean energy technologies, such as smart energy networks, tidal power and energy storage.

The European Climate, Infrastructure and Environment Executive Agency (CINEA) is running parts of Horizon 2020 and Horizon Europe in the areas of transport and energy, as well as innovation of energy efficient technologies and solutions for buildings, heating and cooling and more.



European Union Funding Programms
Funding for energy action

InvestEU

The InvestEU Programme supports sustainable investment, innovation and job creation in Europe.

It will bring together, under one roof, the European Fund for Strategic Investments and 13 other EU financial instruments and aims to trigger more than €372 billion in additional investment over the period 2021-2027.



European Union Funding Programms
Funding for energy action

Just Transition Mechanism

The Just Transition Mechanism is a financial tool that provide tailored support to the most vulnerable and coal-intensive regions in the transition to a greener economy. Over the period 2021-2027, it will mobilise at least €150 billion of investments to alleviate the socio-economic impact.

The mechanism consists of three pillars

- a Just Transition Fund of €40 billion to primarily provide grants
- a dedicated scheme under InvestEU to crowd in private investments
- a public sector loan facility with the EIB Group to mobilise additional investments and leverage public financing



European Union Funding Programms
Funding for energy action

LIFE: Clean Energy Transition

The new sub-programme of the LIFE Programme is dedicated to clean energy transition. It aims to offer support to deliver on sustainable energy-related policies that contribute to reach the European Green Deal objectives.

With a budget close to € 1 billion for the period 2021-2027, the sub-programme aims to facilitate the transition towards an energy efficient, renewable energy based and resilient economy by funding coordination and support actions across Europe. It is managed by CINEA.



European Union Funding Programms
Funding for energy action

Recovery and Resilience Facility

The Recovery and Resilience Facility (RRF) is the key instrument at the heart of NextGenerationEU, the EU's plan for emerging stronger from the COVID-19 pandemic.

It is structured around 6 pillars: green transition; digital transformation; economic cohesion, productivity and competitiveness; social and territorial cohesion; health, economic, social and institutional resilience; policies for the next generation.

The RRF will help the EU achieve its target of climate neutrality by 2050.



European Union Funding Programms
Funding for energy action

European Energy Programme for Recovery

Launched in 2009 in order to support key investments in the context of the economic crisis and in order to promote energy transition, the €3.98 billion European Energy Programme for Recovery (EEPR) finance aimed to fund 44 gas and electricity infrastructure projects, 9 offshore wind projects and 6 carbon capture and storage projects.

After 7 years of implementation, EEPR achieved good results in 2018. 35 projects out of 44 in gas and electricity infrastructure projects were completed; 4 out of 9 in the offshore wind projects are operational, but only 1 in the carbon capture and storage projects. The EEPR website was archived in 2019.

The Commission continues to monitor closely the on-going remaining projects. Lessons learned from EEPR were used in the preparation and the implementation of the projects of common interest (PCI). Under the EEPR, the Commission also launched the European Energy Efficiency Fund (EEE-F) which aims at promoting a sustainable energy market and climate protection.



European Union Funding Programms
Funding for energy action

EIC Accelerator Funding and investments through the EIC Fund for individual start-ups and small companies to develop and scale up game changing innovations



The EIC Accelerator provides substantial financial support with: grant funding (non-dilutive) of up to €2.5 million for innovation development costs, investments (direct equity investments) of up to €15 million managed by the EIC Fund for scale up and other relevant costs.

Companies working on technologies of strategic European interest can apply for EIC investments of more than €1.5 million. In addition, EIC selected companies receive coaching, mentoring, access to investors and corporates, and many other opportunities as part of the EIC community.



European Union Funding Programms
Funding for climate action

Research - Innovate 2021-2027

The aim of the action is to strengthen Research and Innovation, which is fully aligned with the country's strategy to place innovation at the heart of a sustainable and resilient recovery from the pandemic, to accelerate the green and digital transition and ensure technological development of Greece.

Its main objective is to connect research and innovation with entrepreneurship and to strengthen the competitiveness, productivity and extroversion of companies towards international markets, with the aim of transitioning to quality innovative entrepreneurship and increasing domestic added value.

It is addressed to companies and research organizations that will carry out collaborative Research and Development projects.



CALLS FOR PROPOSAL

European Union Funding Programms
Calls for proposal

Horizon Europe: EUR 99 million of funding available for Energy R&I projects



Description
EU funding of EUR 99 million in total is now available for Horizon Europe Energy topics with a deadline of 27 October 2022 at 5pm (CEST).

LIFE-2022-CET-LOCAL - Technical support to clean energy transition plans and strategies in municipalities and regions

Description
Commission has launched on 17 May 2022 the LIFE Programme Calls for proposals.
This year, there is €598 million available for nature conservation, environmental protection, climate action, and clean energy transition projects.

European Union Funding Programms
Calls for proposal

LIFE-2022-CET-POLICY -Towards an effective implementation of key legislation in the field of sustainable energy



Description
Commission has launched on 17 May 2022 the LIFE Programme Calls for proposals.
This year, there is €598 million available for nature conservation, environmental protection, climate action, and clean energy transition projects.

LIFE-2022-CET-COMPLIANCE - New ecolabel and energy labelling compliance support facility for suppliers and retailers

Description
Commission has launched on 17 May 2022 the LIFE Programme Calls for proposals.
This year, there is €598 million available for nature conservation, environmental protection, climate action, and clean energy transition projects.

European Union Funding Programms

Calls for proposal

LIFE-2022-CET-EE1st - Making the “Energy efficiency first” principle more operational

Description

Commission has launched on 17 May 2022 the LIFE Programme Calls for proposals. This year, there is €598 million available for nature conservation, environmental protection, climate action, and clean energy transition projects.

LIFE-2022-CET-DEEPRENO - Towards a zero-emission building stock: strengthening the enabling framework for deep renovation

Description

Commission has launched on 17 May 2022 the LIFE Programme Calls for proposals. This year, there is €598 million available for nature conservation, environmental protection, climate action, and clean energy transition projects.



European Union Funding Programms

Calls for proposal

LIFE-2022-CET-BUILDPERFORM - Energy performance and Smart Readiness of buildings – making the instruments work

Description

Commission has launched on 17 May 2022 the LIFE Programme Calls for proposals. This year, there is €598 million available for nature conservation, environmental protection, climate action, and clean energy transition projects.

LIFE-2022-CET-BUSINESS - Supporting the clean energy transition of the business sector

Description

Commission has launched on 17 May 2022 the LIFE Programme Calls for proposals. This year, there is €598 million available for nature conservation, environmental protection, climate action, and clean energy transition projects.



European Union Funding Programms

Calls for proposal

LIFE-2022-CET-BUILDSKILLS - BUILD UP Skills – Strategies and training interventions enabling a decarbonised building stock

Description

Commission has launched on 17 May 2022 the LIFE Programme Calls for proposals. This year, there is €598 million available for nature conservation, environmental protection, climate action, and clean energy transition projects.

LIFE-2022-CET-DH - Integration of low-grade renewable energy or waste heat in high temperature district heating

Description

Commission has launched on 17 May 2022 the LIFE Programme Calls for proposals. This year, there is €598 million available for nature conservation, environmental protection, climate action, and clean energy transition projects.



European Union Funding Programms

Calls for proposal

LIFE-2022-CET-HEATPUMPS - Accelerating deployment and affordability of heat pumps through collective purchase actions and procurement

Description

Commission has launched on 17 May 2022 the LIFE Programme Calls for proposals. This year, there is €598 million available for nature conservation, environmental protection, climate action, and clean energy transition projects.

LIFE-2022-CET-MAINSTREAM - Mainstreaming sustainable energy investments in the financial sector

Description

Commission has launched on 17 May 2022 the LIFE Programme Calls for proposals. This year, there is €598 million available for nature conservation, environmental protection, climate action, and clean energy transition projects.



European Union Funding Programms
Calls for proposal

LIFE-2022-CET-FINROUND - National Finance Roundtables for sustainable energy investments

Description
Commission has launched on 17 May 2022 the LIFE Programme Calls for proposals. This year, there is €598 million available for nature conservation, environmental protection, climate action, and clean energy transition projects.

LIFE-2022-CET-INNOFIN - Innovative financing schemes for sustainable energy investments

Description
Commission has launched on 17 May 2022 the LIFE Programme Calls for proposals. This year, there is €598 million available for nature conservation, environmental protection, climate action, and clean energy transition projects.



European Union Funding Programms
Calls for proposal

LIFE-2022-CET-HOMERENO - Integrated Home Renovation Services

Description
Commission has launched on 17 May 2022 the LIFE Programme Calls for proposals. This year, there is €598 million available for nature conservation, environmental protection, climate action, and clean energy transition projects.

LIFE-2022-CET-RENOPUB - Setting up facilitation structures to accelerate the renovation wave in the public sector

Description
Commission has launched on 17 May 2022 the LIFE Programme Calls for proposals. This year, there is €598 million available for nature conservation, environmental protection, climate action, and clean energy transition projects.



European Union Funding Programms
Calls for proposal

LIFE-2022-CET-PDA - Project Development Assistance for sustainable energy investments

Description
Commission has launched on 17 May 2022 the LIFE Programme Calls for proposals. This year, there is €598 million available for nature conservation, environmental protection, climate action, and clean energy transition projects.

LIFE-2022-CET-ENERPOV - Addressing building related interventions in vulnerable districts

Description
Commission has launched on 17 May 2022 the LIFE Programme Calls for proposals. This year, there is €598 million available for nature conservation, environmental protection, climate action, and clean energy transition projects.



European Union Funding Programms
Calls for proposal

LIFE-2022-CET-ENERCOM - Developing support mechanisms for energy communities

Description
Commission has launched on 17 May 2022 the LIFE Programme Calls for proposals. This year, there is €598 million available for nature conservation, environmental protection, climate action, and clean energy transition projects..

CEF Energy 2022 - Call for Preparatory Studies for Cross-border Renewable Energy Projects

Description
The 2022 CEF Energy call for proposals for preparatory studies for cross-border renewable energy projects will make €1 million available to support both EU Member States and private project promoters in selecting the best project concept and setting up the cooperation agreement. That way, the call allows for projects to be supported before being included in the Union list of cross-border RES projects.



European Union Funding Programms
Calls for proposal

**LIFE-2022-STRAT-NAT-SNAP-two-stage - Strategic Nature
Projects (SNAP)**

Description
Commission has launched on 17 May 2022 the LIFE Programme Calls for proposals.
This year, there is €598 million available for nature conservation, environmental protection, climate action, and clean energy transition projects.

**LIFE-2022-STRAT-ENV-SIP-two-stage Strategic Integrated
Projects - Environment (SIP)**

Description
Commission has launched on 17 May 2022 the LIFE Programme Calls for proposals.
This year, there is €598 million available for nature conservation, environmental protection, climate action, and clean energy transition projects.



European Union Funding Programms
Calls for proposal

**LIFE-2022-STRAT-CLIMA-SIP-two-stage Strategic Integrated Projects -
Climate Action (SIP)**

Description
Commission has launched on 17 May 2022 the LIFE Programme Calls for proposals.
This year, there is €598 million available for nature conservation, environmental protection, climate action, and clean energy transition projects.

Just Transition Mechanism Public Sector Loan Facility call for proposals

Description
The Public Sector Loan Facility (PSLF) is the third pillar of the Just Transition Mechanism. It supports projects addressing the challenges deriving from the transition to the European Union's climate target objectives in the territories most negatively affected by the climate transition as identified in the previously approved Territorial Just Transition Plans.
PSLF is a blending instrument combining grants up to EUR 1.525 billion from the EU budget with loans up to EUR 10 billion from the European Investment Bank, and aiming to mobilise around EUR 18.5 billion of public investments. Successful projects receive a grant from the European Commission and a loan from the European Investment Bank.

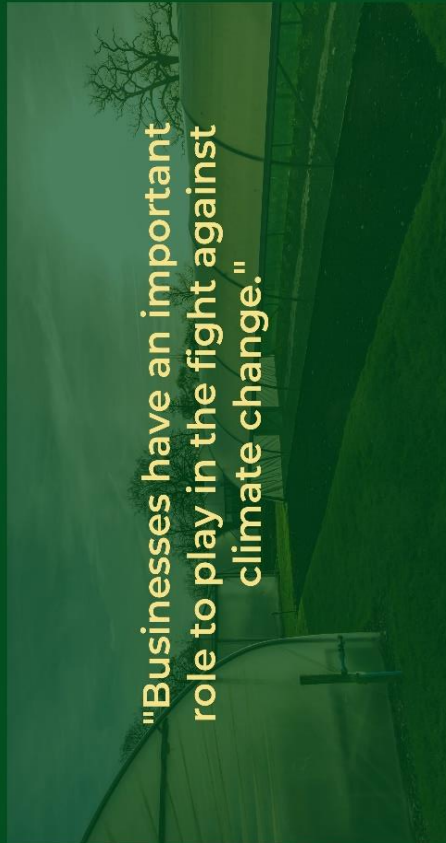

**"Businesses have an important
role to play in the fight against
climate change."**

THANK YOU

- +30 211 215 5988
- info@ependysis.eu
- 13 Filadelfeias str, Nea Smyrni, Greece
- www.eependysis.eu

Deger Hellas

Dr. Ioannis MARKOPOULOS

Welcome to Markopoulos Energy & Mechatronic Systems

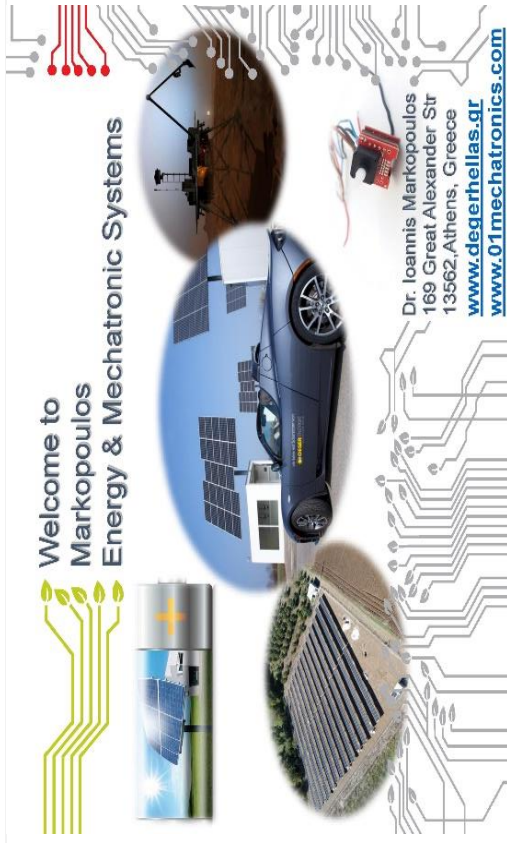

Dr. Ioannis Markopoulos
169 Great Alexander Str
13502 Athens, Greece
www.degerhellas.gr
www.o1mechatronics.com

DEGER HELLAS



Solar Tracking 8000 systems

Smart EV-charging

IoT and Robotics

ZERO ONE ENERGY

ZERO ONE MECHATRONICS

DEGER HELLAS

DegerHellas LTD



12 years activity in Greece/Cyprus/Balkans

100-MW PV installations

8000 systems installed in the Area

DEGER HELLAS

15th Annual Energy and Climate Change Conference, 14/10/2022

Our Commitment



Maximum Solar Storage

MSS

Optimise Solar Energy Production



15th Annual Energy and Climate Change Conference, 14/10/2022



Solar Trackers

A solar tracker is a device that orients a payload toward the Sun. Payloads are usually solar panels, parabolic reflectors, fresnel lenses or the mirrors of a heliostat.



15th Annual Energy and Climate Change Conference, 14/10/2022



Types

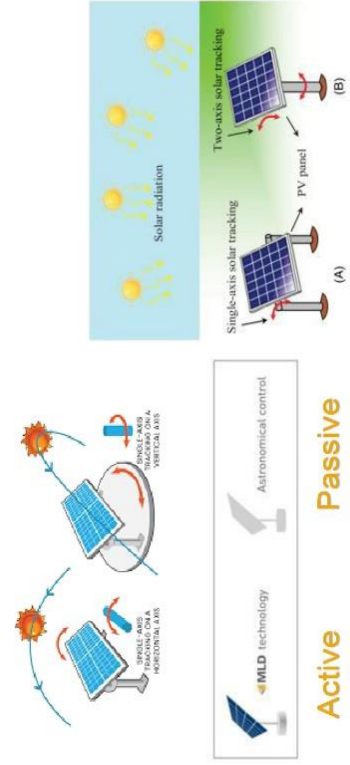

15th Annual Energy and Climate Change Conference, 14/10/2022



MAXIMUM LIGHT DETECTION (MLD)

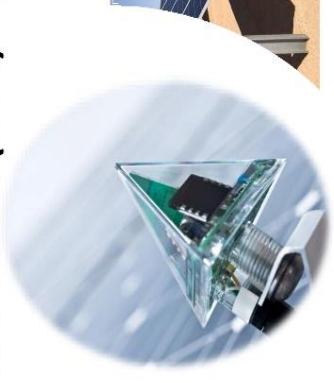

15th Annual Energy and Climate Change Conference, 14/10/2022



MAXIMUM LIGHT DETECTION MLD BY DEGER

We achieve increase in solar production over fixed by 25% and +8% over Astronomical with a brilliant way



MAXIMUM LIGHT DETECTION (1)

MAXIMUM LIGHT DETECTION (2)

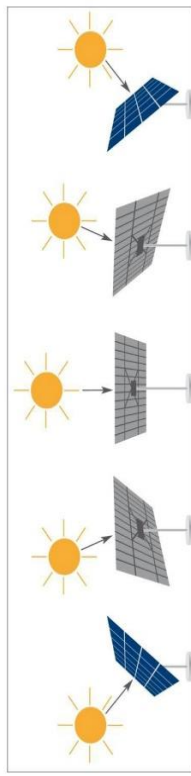

Sunshine:
The DEGERtracker directly faces the sun all day.

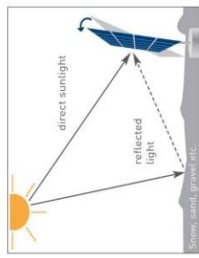

Reflecting surface:

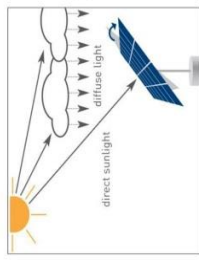

Partly clouded:

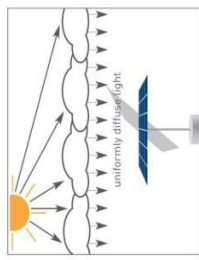

Overcast sky:



16th Annual Energy and Climate Change Conference, 14/10/2022



16th Annual Energy and Climate Change Conference, 14/10/2022

MAXIMUM LIGHT DETECTION (3)

TRACKING SYSTEM

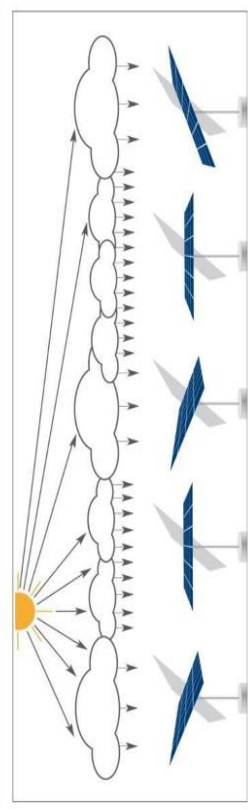

Varying light conditions:
Because of different levels of cloudiness, the light conditions in solar parks vary for each DEGERtracker. The individual control makes sure every DEGERTracker is optimally oriented to the brightest source of irradiation. This guarantees the highest energy yield possible.



15th Annual Energy and Climate Change Conference, 14/10/2022

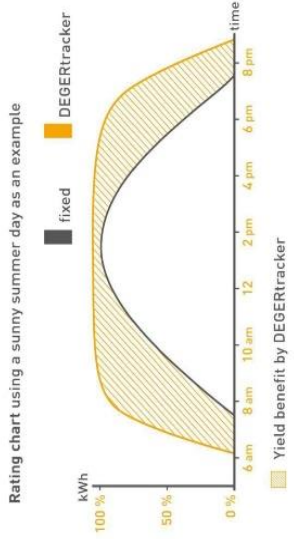

EFFICIENCY RECORD AND HIGHEST RATES OF EFFICIENCY



Real Innovation



15th Annual Energy and Climate Change Conference, 14/10/2022



PRODUCT OVERVIEW

Building Integration

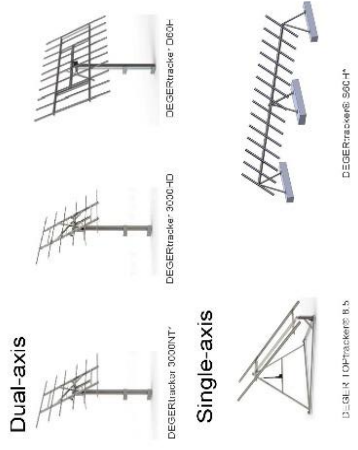

15th Annual Energy and Climate Change Conference, 14/10/2022



PRODUCT OVERVIEW

Open Land

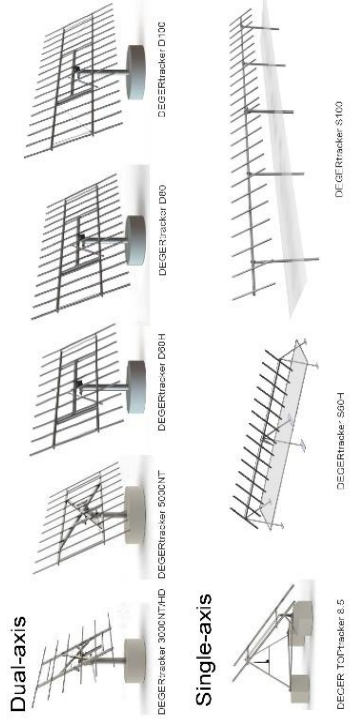

15th Annual Energy and Climate Change Conference, 14/10/2022



Projects





Projects



EXAMPLES

Solar parks with dual-axis trackers – Germany, Spain, Canada, South Africa



15th Annual Energy and Climate Change Conference, 14/10/2022



EXAMPLES

Solar parks with single-axis trackers - Italy, Spain, Turkey, Namibia



15th Annual Energy and Climate Change Conference, 14/10/2022

























EXAMPLES

Building integration



15th Annual Energy and Climate Change Conference, 14/10/2022

<p style="text-align: center;">DEGER HELLAS</p> <p style="text-align: center;">EXAMPLES</p> <p><i>DEGERtracker worldwide</i></p>  <p>Belgium Zolder Raceway</p>  <p>Sweden E18 Highway Stockholm</p> <p style="text-align: right;">15th Annual Energy and Climate Change Conference, 14/10/2022</p> <p style="text-align: right;">    </p>	<p style="text-align: center;">DEGER HELLAS</p> <p style="text-align: center;">EXAMPLES</p> <p><i>DEGERtracker worldwide</i></p>  <p>Tunis Airport</p>  <p>Dubai University</p>  <p>India Pune</p> <p style="text-align: right;">15th Annual Energy and Climate Change Conference, 14/10/2022</p> <p style="text-align: right;">    </p>
<p style="text-align: center;">DEGER HELLAS</p> <p style="text-align: center;">EXAMPLES</p> <p><i>DEGERtracker worldwide</i></p>  <p>Ghana Energy Commission</p>  <p>Australia Desert Knowledge Solar Centre</p>  <p>South Africa Kruger National Park</p> <p style="text-align: right;">15th Annual Energy and Climate Change Conference, 14/10/2022</p> <p style="text-align: right;">    </p>	<p style="text-align: center;">DEGER HELLAS</p> <p style="text-align: center;">EXAMPLES</p> <p><i>DEGERtracker worldwide</i></p>  <p>USA Tennessee</p>  <p>Canada British Columbia</p>  <p>USA Anchorage Airport</p> <p style="text-align: right;">15th Annual Energy and Climate Change Conference, 14/10/2022</p> <p style="text-align: right;">    </p>



Projects - DegerHellas

DEGERtracker Greece



DEGERtracker Greece 500kW (GREENTOP)

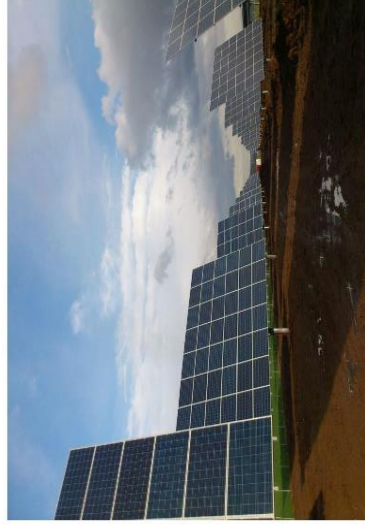

150MW in GREECE / 3500 Systems



Solar brain



DegerTrackers
Χωρίς Backtracking



DegerTrackers
Με Backtracking



Solar brain is an IoT device



Solar brain is an IoT device Manufactured In Greece



Solar brain is an IoT device



DEGERtracker - Examples





Projects



Building Integration



Knowledge in Autonomous Systems

Solar Home Systems (SHS)
50 – 300 Wp



PIV Pumping Systems
2 kWp

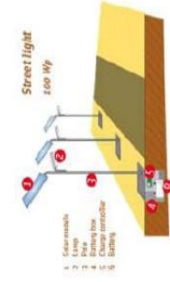
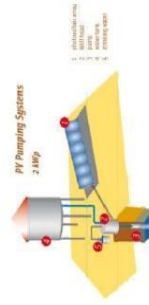

Power Supplies for Microcommunication Systems
30 Wp

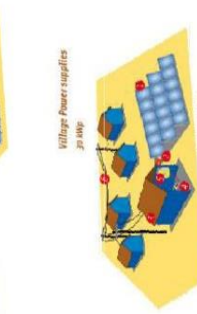

15th Annual Energy and Climate Change Conference, 14/10/2022



Maximum Solar Storage by DEGERHellas



15th Annual Energy and Climate Change Conference, 14/10/2022





Knowledge Autonomous PV

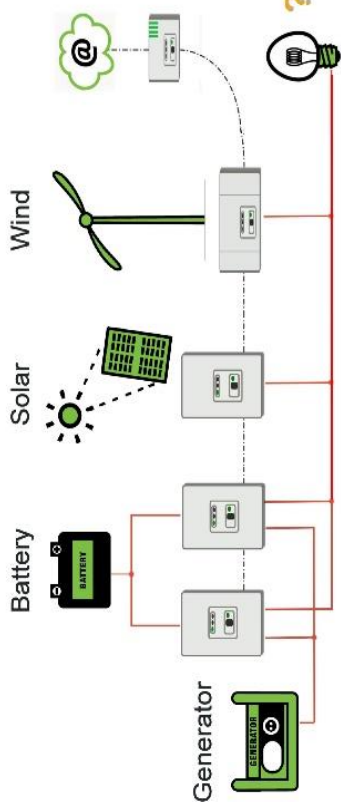

15th Annual Energy and Climate Change Conference, 14/10/2022

Offering Autonomous Systems

Οι επιλογές είναι απεριόριστες
Συστήματα από 15kW – 200kW peak ισχύος

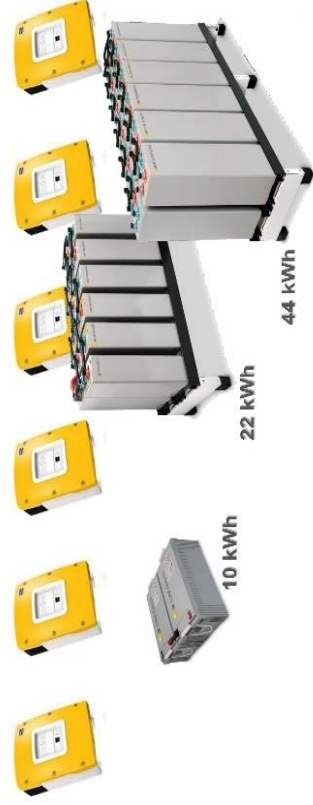

15th Annual Energy and Climate Change Conference, 14/10/2022



Maximum Solar Storage by DEGERHellas

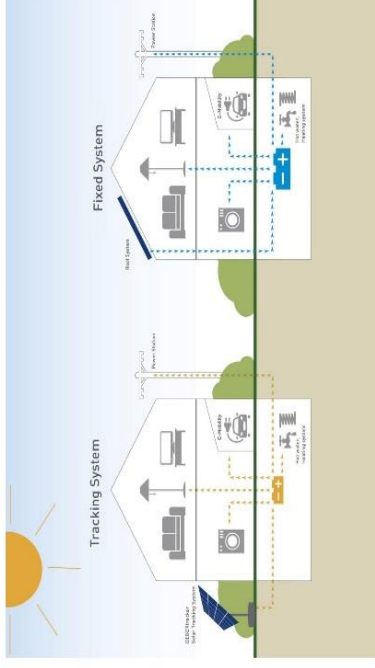

15th Annual Energy and Climate Change Conference, 14/10/2022

Just like a household apparatus



15th Annual Energy and Climate Change Conference, 14/10/2022

A small autonomous PV production plant (30kW)



15th Annual Energy and Climate Change Conference, 14/10/2022



Architecture

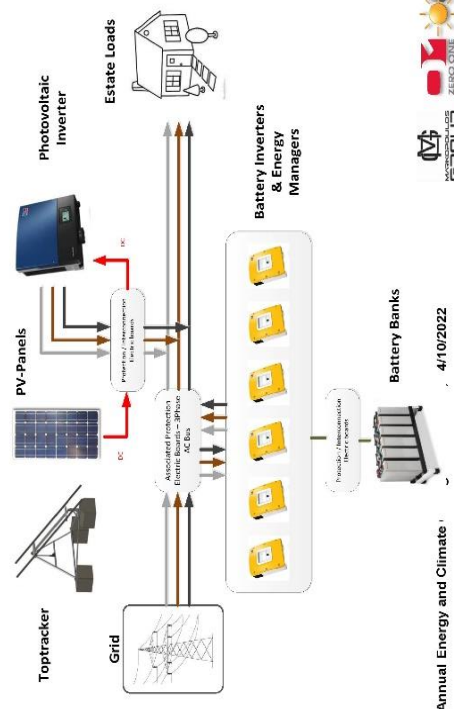

15th Annual Energy and Climate Change Conference, 14/10/2022



An 40kWh PV production plant

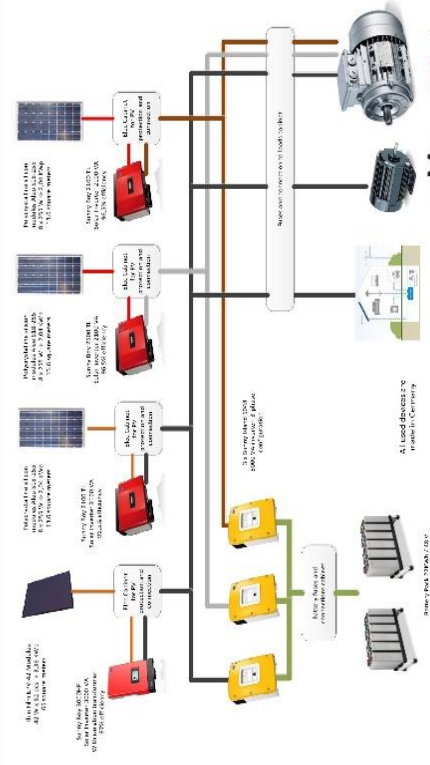

15th Annual Energy and Climate Change Conference, 14/10/2022



A COMPLETE SYSTEM

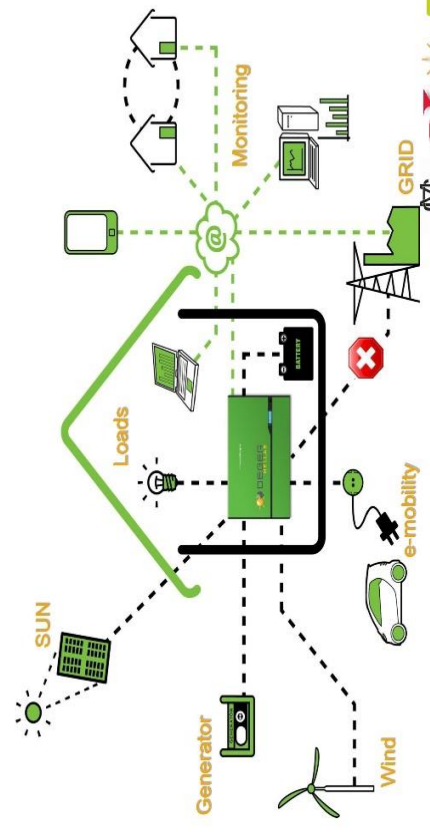

15th Annual Energy and Climate Change Conference, 14/10/2022





A VISION FOR THE FUTURE

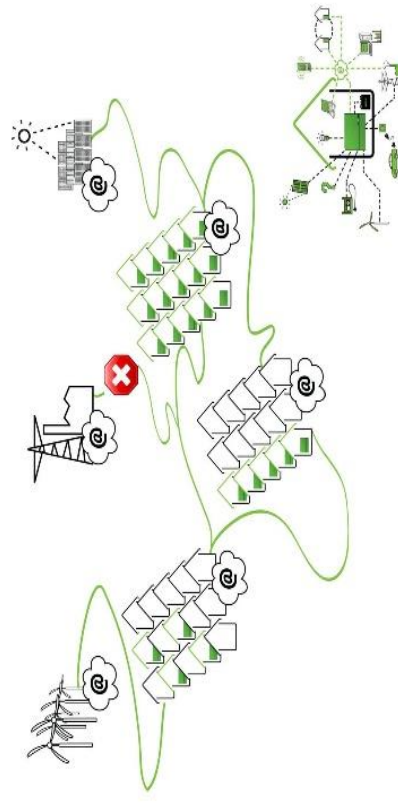

15th Annual Energy and Climate Change Conference, 14/10/2022



Energy Autonomy in Africa

- The International Energy Agency estimates that 585 million people in sub-Saharan Africa lack access to electricity
- In East Africa, only 23% of Kenyans, 10.8% of Rwandans and 14.8% of Tanzanians have electricity, the World Bank says
- Off-grid households in East Africa spend about \$0.50-\$0.60 (33p-40p) per day on kerosene lighting and basic charging costs

15th Annual Energy and Climate Change Conference, 14/10/2022



PROVIDING SIMPLE SOLUTIONS BRINGING

“Energy to the People”

15th Annual Energy and Climate Change Conference, 14/10/2022



WE GOT THE SOLUTIONS

15th Annual Energy and Climate Change Conference, 14/10/2022



DEGER HELLAS

What our MSS systems can offer

15th Annual Energy and Climate Change Conference, 14/10/2022

GROUP **RESponsible** **GREEN** **ZERO ONE**

DEGER HELLAS

Personal Light Systems

HOW DOES IT WORK?

Charge the lamp storage system!

Use your electronic equipments!

Set the solar panel into the sun, and connect it to the lamp.

Anytime and anywhere you can connect to the loaded lamp storage system by mobile charger too.

15th Annual Energy and Climate Change Conference, 14/10/2022

GROUP **RESponsible** **GREEN** **ZERO ONE**

DEGER HELLAS

Personal Light Systems

1X

2X

4X

All offering very bright Lights for 5-6 Hours operation

15th Annual Energy and Climate Change Conference, 14/10/2022

GROUP **RESponsible** **GREEN** **ZERO ONE**

DEGER HELLAS

DEGERHELLAS MSS 800VA|2kWh for a house

1	Photovoltaic Panel
2	Automatic Solar Inverter
3	Automatic Solar Charge Controller
4	12V/100AH Lead Acid Battery
5	12V/100AH Lead Acid Battery
6	12V/100AH Lead Acid Battery
7	12V/100AH Lead Acid Battery
8	12V/100AH Lead Acid Battery
9	12V/100AH Lead Acid Battery
10	12V/100AH Lead Acid Battery
11	12V/100AH Lead Acid Battery
12	12V/100AH Lead Acid Battery
13	12V/100AH Lead Acid Battery
14	12V/100AH Lead Acid Battery

15th Annual Energy and Climate Change Conference, 14/10/2022

GROUP **RESponsible** **GREEN** **ZERO ONE**



DEGERHELLAS MSS 800VA



15th Annual Energy and Climate Change Conference, 14/10/2022



What it can offer

The NextBox 300/2000 portable power pack

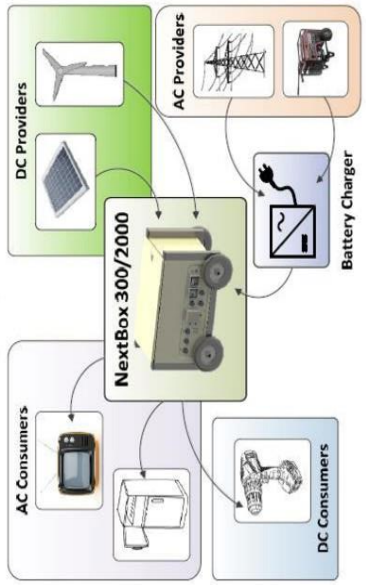

15th Annual Energy and Climate Change Conference, 14/10/2022



DEGERHELLAS MSS BOX

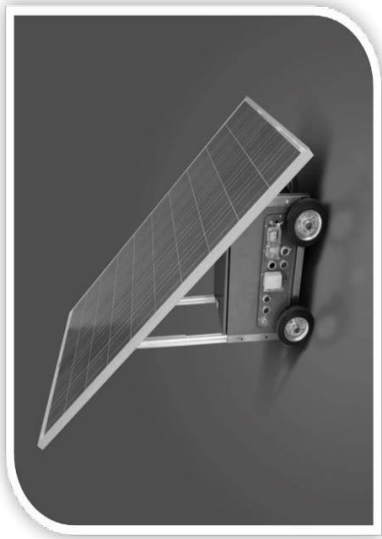

15th Annual Energy and Climate Change Conference, 14/10/2022



15th Annual Energy and Climate Change Conference, 14/10/2022

PJ TECH Catalyst

Mr. Nikos ANTONIOU, President & CEO of PJ TECH Catalyst Management SA



PJ Tech Catalyst Fund – Overview

- Venture Capital Fund of €15mil. (70% EIF, 30% Piraeus Bank)
- 21 investments in seed stage technology start-up companies
- Exits: Accusonus acquired by META, Polifish acquired by Protege, Radiojar acquired by iHeartMedia



Innovative Entrepreneurship - Startups



The process of converting a new & innovative idea into a product (or service) and bringing it to market through a new business (start-up) or existing one

Innovative Entrepreneurship





Innovative Entrepreneurship = high risk



Entrepreneurship + tech = high impact

Funding for Innovative Entrepreneurship



Venture Capital

Investment funds that provide financing to innovative start-up and emerging companies that have high growth potential or have demonstrated high growth

Venture Capital

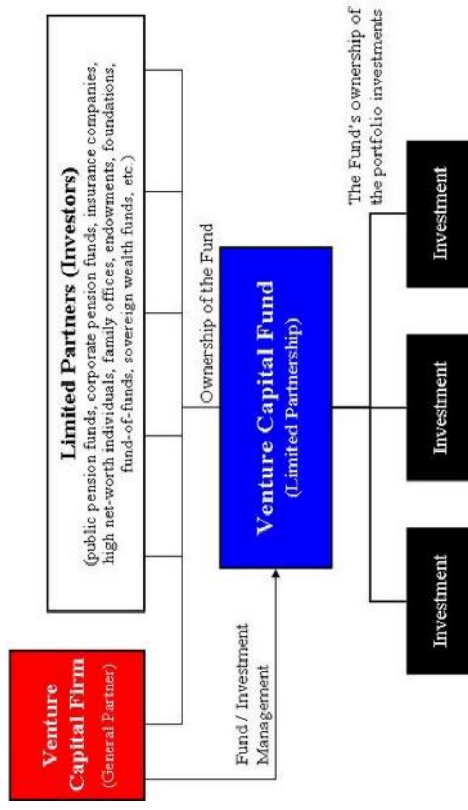

Venture Capital

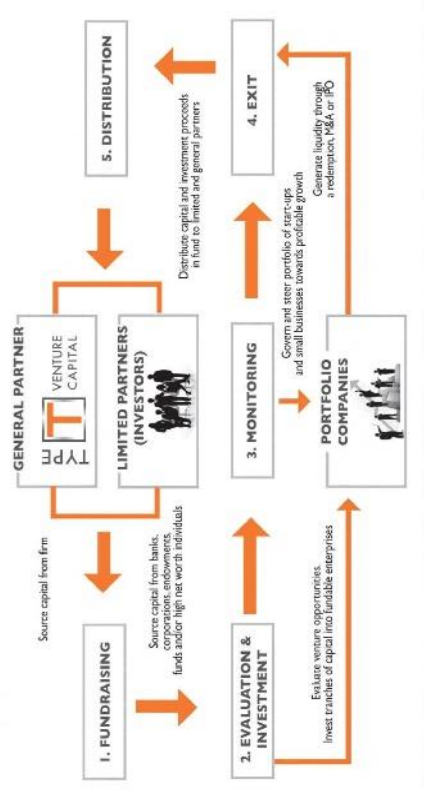

VC Investment Criteria

- Innovative product/service
 - Ownership of IP
 - Apparent customer utility of product/service
 - Large size relevant market
 - Strong competitive advantage
 - GTM and growth strategy
 - Exit potential
- Competent & cohesive team with ability to execute
 - Visionary founders
 - Committed & persevered Team
- High growth potential/scalable BM
 - Strong revenue generation from international markets
 - High Expected IRR

Public Contributors to Greek VC Ecosystem



HELLENIC DEVELOPMENT BANK OF INVESTMENTS

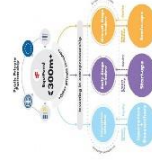

Greek VC Ecosystem

The Greek Startup Ecosystem

Some Statistics...

THE EQUIFUND UP TO NOW (2017-2021)

- 119 Companies funded in 213 rounds
- €620M in total funding
- €210M in seed/early funding
- >120 investors
- 15/10 of companies have a female co-founder
- 8/10 of companies have their HQ in Greece
- 5/10 of companies are up to 4 years old
- 8/10 of companies have a B2B focus (either mainly or partly)

Investors in Greek Startups

Investors in Greek Startups

source: marathon.vc

Acquirers of Greek Startups

Acquirers of Greek Startups

source: marathon.vc

Thank You!

Nik Antoniou
PJ Tech Catalyst Fund - CEO
n.antoniou@pjtechcatalyst.com
Mobile: 6951009275
www.pjtechcatalyst.com

Justified European subsidies to Investments in Research, Technological Development, Innovation and R&D in the field of Green and Digital Transition, through the National Operational Program "Growth and Employment" (NSRF) 2007-2013. Co-financed by Greece and the European Union.

